

# AS1330

## 4MHz, Low Voltage, DC-DC Step-Up Converter

### 1 General Description

The AS1330 is a synchronous, low voltage, high efficiency DC-DC boost converter running at a constant frequency of 4MHz. This very high oscillator frequency allows the usage of a very a small and low profile inductor with only 470nH. This results in a board space requirement of only 43mm<sup>2</sup> for the complete solutions including all external components.

AS1330 generates an output voltage between 1.8 and 3.3V from input voltages down to 0.6V. Therefore it is ideal for application powered by a single cell battery. AS1330 provides an output current of 150mA @ 3.3V from a single cell.

To support high efficiency across the entire load range the AS1330 is equipped with a synchronous rectifier and features a power save mode for light loads.

To avoid harmful deep discharge of the battery during shutdown the AS1330 is equipped with an output disconnect function.

AS1330 can either monitor the battery voltage (Sense pin) or report the status of the output voltage (POK).

The AS1330 is available in a TDFN (2x2mm) 8-pin package.

### 2 Key Features

- Input Voltage Range: 0.6V to 3.0V
- Adjustable Output Voltage Range: 1.8V to 3.3V
- Fixed Output Voltage: 1.8V, 3.0V
- 0.85V Low Start-Up Voltage
- 4MHz Fixed-Frequency
- 91% Efficiency
- Delivers 150mA @ 3.3V (from Single AA Cell)
- Automatic Powersave Operation for light Loads
- Output Disconnect during Shutdown
- Anti-Ringing Control minimizes EMI
- Power Okay and Sense pin
- TDFN (2x2mm) 8-pin Package

### 3 Applications

The AS1330 is ideal for space critical applications where ultra-small size is critical as in medical diagnostic equipment, hand-held instruments, digital cameras, MP3 players, GPS receivers, and PC or Memory cards.

Figure 1. AS1330 - Typical Application Diagram

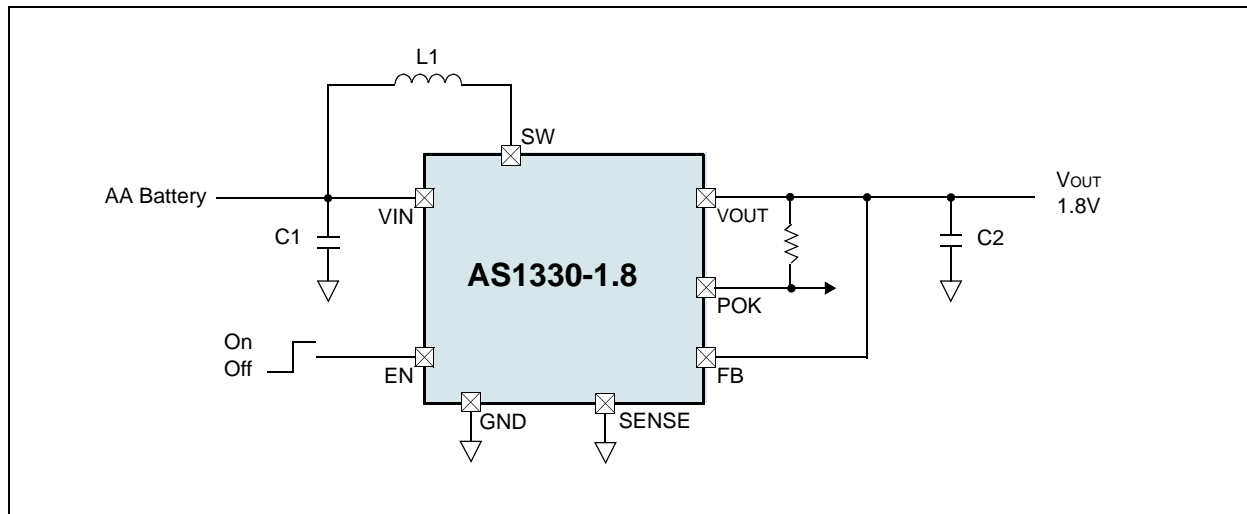

## 4 Pin Assignments

Figure 2. Pin Assignments (Top View)

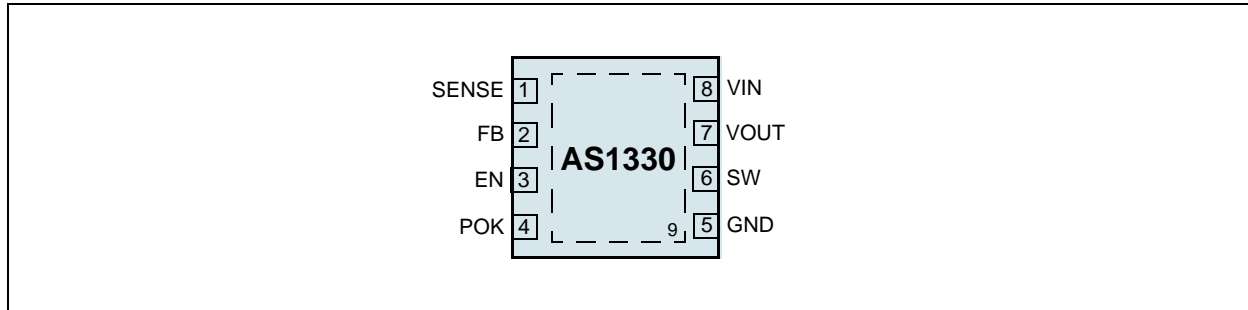

### Pin Descriptions

Table 1. Pin Descriptions

Pin Number	Pin Name	Description
1	SENSE	<b>Sense Input.</b> Represents the input for the Power-OK behaviour. This input can be used to supervise the input or the output voltage via a resistor divider. If connected to GND the POK output is related to VOUT.
2	FB	<b>Feedback Pin.</b> Feedback input to the gm error amplifier. Connect a resistor divider tap to this pin. The output voltage can be adjusted from 1.8 to 3.3V by: $V_{OUT} = 0.8V[1 + (R1/R2)]$ If the fixed output voltage version is used, connect this pin to VOUT.
3	EN	<b>Active-High Enable Input.</b> A logic LOW reduces the supply current to < 1µA. Connect to pin VIN for normal operation.
4	POK	<b>Power-OK Output.</b> Active-High, open-drain output indicates an out-of-regulation condition. Connect a 100kΩ pull-up resistor to pin OUT for logic levels. Leave this pin unconnected if the Power-OK feature is not used. Low Level: VOUT is out of Regulation High Level: VOUT is within Regulation
5	GND	<b>Signal and Power Ground.</b> Provide a short, direct PCB path between this pin and the negative side of the output capacitor(s).
6	SW	<b>Switch Pin.</b> Connect an inductor between this pin and VIN. Keep the PCB trace lengths as short and wide as is practical to reduce EMI and voltage overshoot. If the inductor current falls to zero, or pin EN is low, an internal 100Ω anti-ringing switch is connected from this pin to VIN to minimize EMI. <b>Note:</b> An optional Schottky diode can be connected between this pin and VOUT.
7	VOUT	<b>Output Voltage.</b> Bias is derived from VOUT when VOUT exceeds VIN. PCB trace length from VOUT to the output filter capacitor(s) should be as short and wide as is practical.
8	VIN	<b>Input Voltage.</b> The AS1330 gets its start-up bias from VIN unless VOUT exceeds VIN, in which case the bias is derived from VOUT. Thus, once started, operation is completely independent from VIN. Operation is only limited by the output power level and the internal series resistance of the supply.
9		<b>Exposed Pad.</b> The exposed pad must be connected to GND. Ensure a good connection to the PCB to achieve optimal thermal performance.

## 5 Absolute Maximum Ratings

Stresses beyond those listed in [Table 2](#) may cause permanent damage to the device. These are stress ratings only, and functional operation of the device at these or any other conditions beyond those indicated in [Section 6 Electrical Characteristics on page 4](#) is not implied. Exposure to absolute maximum rating conditions for extended periods may affect device reliability.

Table 2. Absolute Maximum Ratings

Parameter	Min	Max	Units	Notes
<b>Electrical Parameters</b>				
All Pins to GND	-0.3	5	V	
Input Current (latch-up immunity)	-100	100	mA	Norm: JEDEC 78
<b>Electrostatic Discharge</b>				
Human Body Model	2		kV	Norm: MIL 883 E method 3015
<b>Temperature Ranges and Storage Conditions</b>				
Storage Temperature Range	-55	+150	°C	
Package Body Temperature		+260	°C	The reflow peak soldering temperature (body temperature) specified is in accordance with <i>IPC/JEDEC J-STD-020 "Moisture/Reflow Sensitivity Classification for Non-Hermetic Solid State Surface Mount Devices"</i> . The lead finish for Pb-free leaded packages is matte tin (100% Sn).
Humidity non-condensing	5	85	%	
Moisture Sensitive Level	1			Represents a max. floor life time of unlimited

## 6 Electrical Characteristics

$V_{IN} = +1.2V$ ,  $V_{OUT} = +3.0V$ ,  $V_{EN} = +1.3V$ ,  $L = 1\mu H$ ,  $C1 = C2 = 10\mu F$ , Typ values @  $T_{AMB} = +25^{\circ}C$  (unless otherwise specified).

Table 3. Electrical Characteristics

Symbol	Parameter	Conditions	Min	Typ	Max	Units
TAMB	Operating Temperature Range		-40		+85	°C
<b>Input</b>						
	Minimum Start-Up Voltage	I <sub>OUT</sub> = 1mA		0.85	0.9	V
V <sub>IN</sub>	Operating Voltage Range <sup>1</sup>	I <sub>OUT</sub> = 1mA	0.6		3.0	V
<b>Regulation</b>						
V <sub>OUT</sub>	Output Voltage Adjust Range <sup>2</sup>		1.8		3.0	V
	Output Voltage Accuracy	V <sub>OUT</sub> > V <sub>IN</sub> + 0.6V	-3		+3	%
V <sub>FB</sub>	Feedback Voltage	for adjustable V <sub>OUT</sub> only	0.776	0.8	0.824	V
I <sub>FB</sub>	Feedback Input Current	V <sub>FB</sub> = 0.8V		10		nA
<b>Operating Current</b>						
I <sub>QPWS</sub>	Quiescent Current (Powersave Operation)	V <sub>OUT</sub> = 3.15V		30	50	μA
I <sub>QSHDN</sub>	Quiescent Current (Shutdown)	V <sub>EN</sub> = 0V		0.05	5	μA
I <sub>Q</sub>	Quiescent Current (Active)	in continuous mode		3		mA
<b>Switches</b>						
I <sub>LKN</sub>	NMOS Switch Leakage	V <sub>sw</sub> = 3.6V		0.1	5	μA
I <sub>LKP</sub>	PMOS Switch Leakage <sup>3</sup>	V <sub>sw</sub> = V <sub>OUT</sub> = 3.6V		0.1	5	μA
R <sub>ONMOS</sub>	NMOS Switch On Resistance			0.25		Ω
R <sub>ONPMOS</sub>	PMOS Switch On Resistance			0.35		Ω
I <sub>NMOS</sub>	NMOS Current Limit			650		mA
	Maximum Duty Cycle <sup>1</sup>		80	87		%
f <sub>sw</sub>	Switching Frequency		3.2	4	4.8	MHz
<b>Shutdown</b>						
V <sub>ENH</sub>	EN Input High	no load	1.2			V
V <sub>ENL</sub>	EN Input Low	no load			0.25	V
I <sub>EN</sub>	EN Input Current	internal pull-down resistor		1	1.5	μA
<b>Power-OK<sup>4</sup></b>						
	POK Voltage Low	I <sub>POK</sub> = 1mA		0.1	0.4	V
	POK Leakage Current	V <sub>POK</sub> = 3V, T <sub>AMB</sub> = 25°C		1	100	nA
	Power-OK Threshold	Monitor V <sub>IN</sub> , Falling Edge	0.72		0.76	V
		Monitor V <sub>OUT</sub> , Falling Edge	90	92.5	95	%

1. Guaranteed by design and verified in lab characterisation.
2. External Schottky diode is mandatory for output voltages higher than 3V.
3. V<sub>OUT</sub> is forced to 3.6V in production test.
4. The POK parameters are tested with proprietary test modes. The POK signal is valid from V<sub>OUT</sub> = 1.9V to 3.0V.

**Note:** All limits are guaranteed. The parameters with min and max values are guaranteed with production tests or SQC (Statistical Quality Control) methods.

## 7 Typical Operating Characteristics

$V_{IN} = 1.2V$ ,  $V_{OUT} = 1.8V$ ,  $L = 1\mu H$ ,  $C1 = C2 = 10\mu F$ ,  $T_{AMB} = +25^{\circ}C$  (unless otherwise specified);

Figure 3. Efficiency vs. Output Current,  $V_{OUT} = 1.8V$

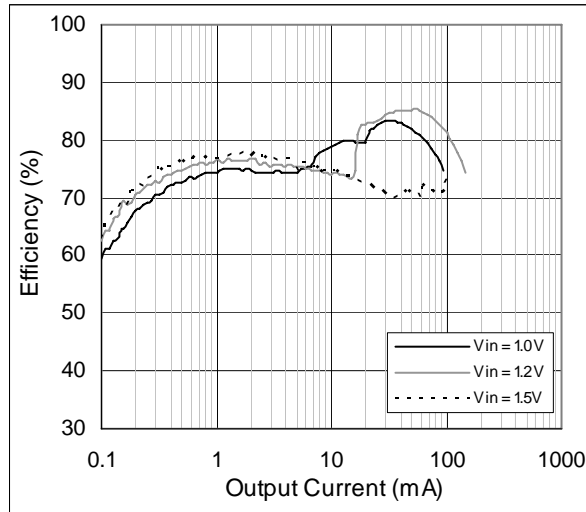

Figure 4. Efficiency vs. Input Voltage,  $V_{OUT} = 1.8V$

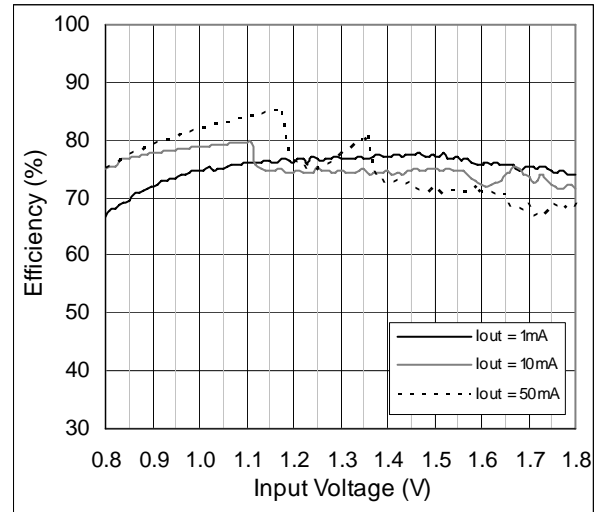

Figure 5. Efficiency vs. Output Current,  $V_{OUT} = 3.0V$

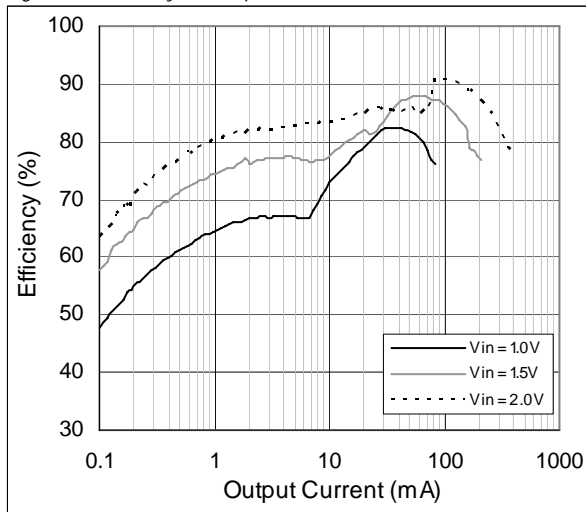

Figure 6. Efficiency vs. Input Voltage,  $V_{OUT} = 3.0V$

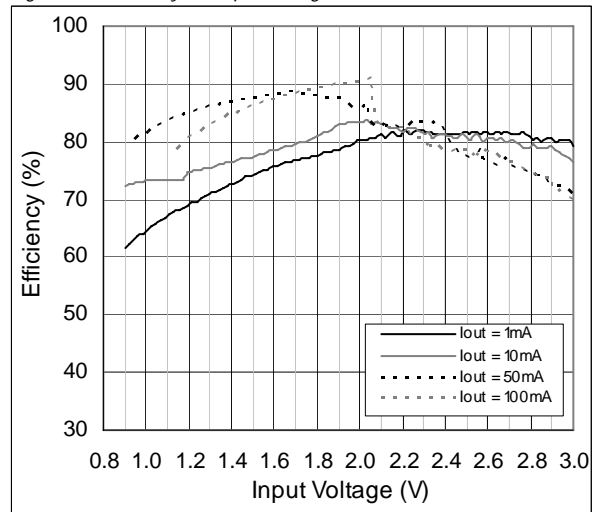

Figure 7. Efficiency vs.  $I_{OUT}$ , Coil Comparison

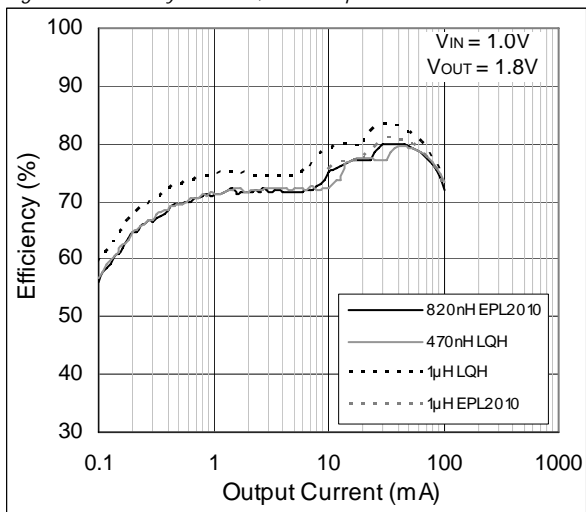

Figure 8. Efficiency vs.  $I_{OUT}$ , Coil Comparison

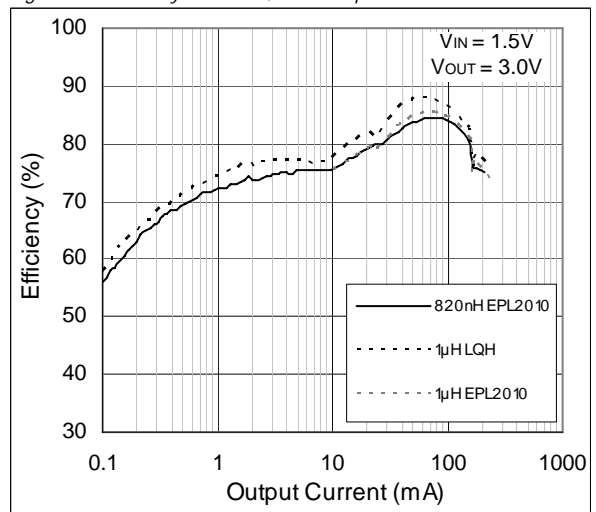

Figure 9.  $I_{OUT}$  vs.  $V_{IN}$ ;  $V_{OUT} = 1.8V$

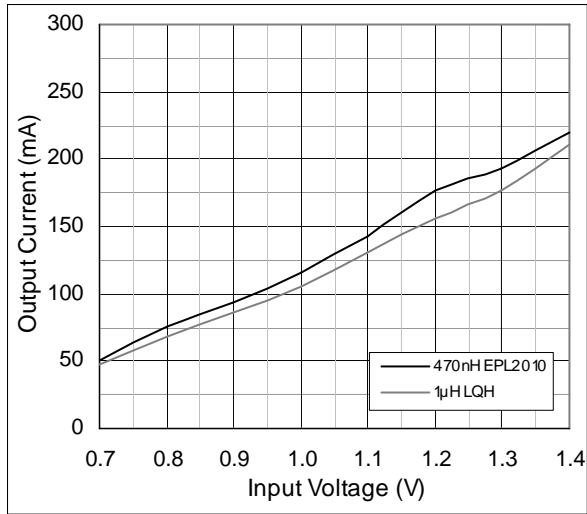

Figure 10.  $I_{OUT}$  vs.  $V_{IN}$ ;  $V_{OUT} = 3.0V$

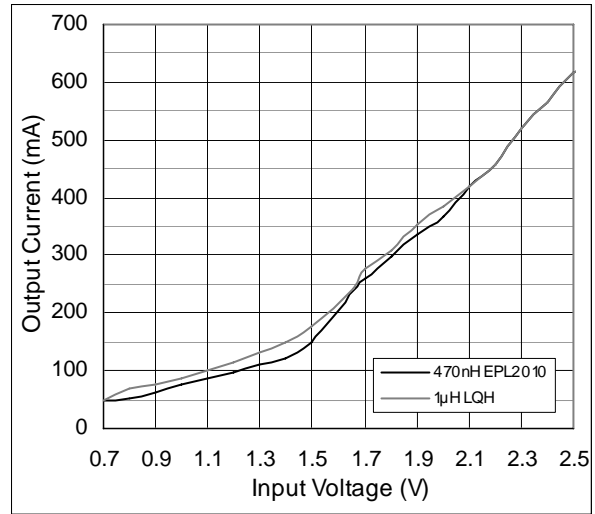

Figure 11. Powersave Threshold vs.  $V_{IN}$

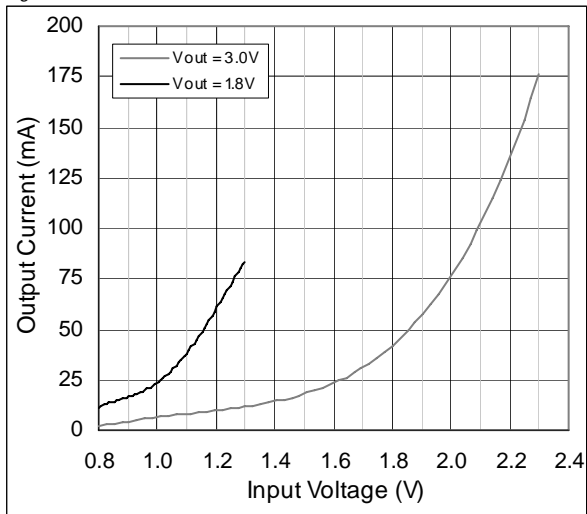

Figure 12.  $V_{OUT}$  vs.  $V_{IN}$ ;  $I_{OUT} = 1mA$

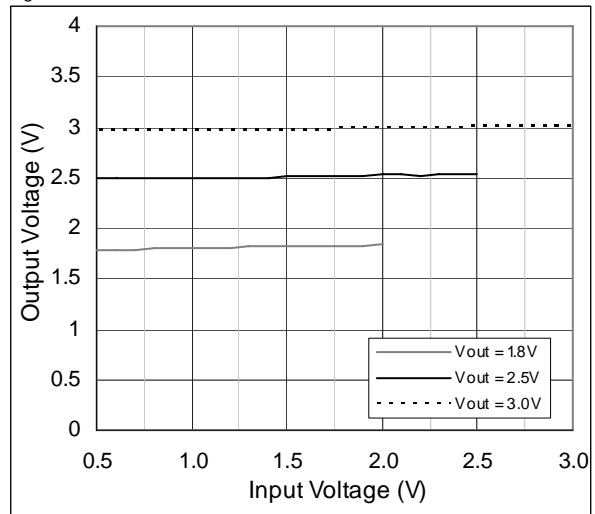

Figure 13. Startup Voltage vs. Output Current

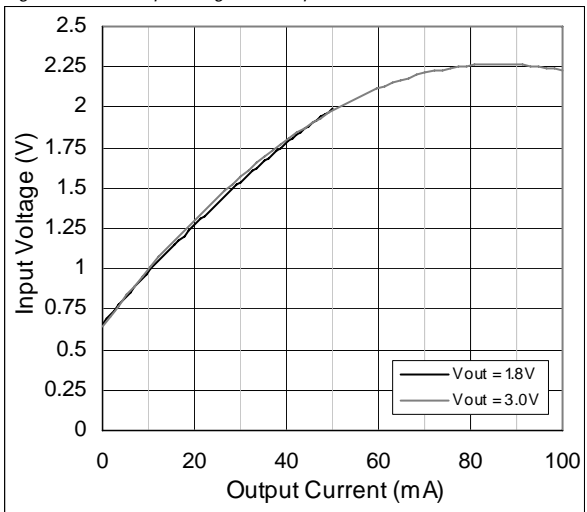

Figure 14. Input Current vs. Input Voltage

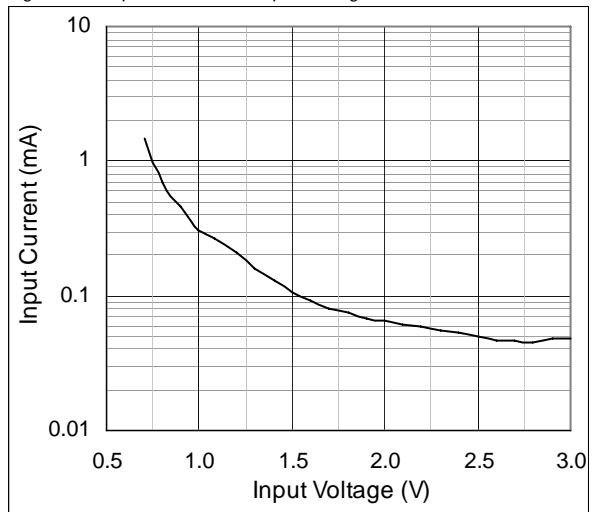
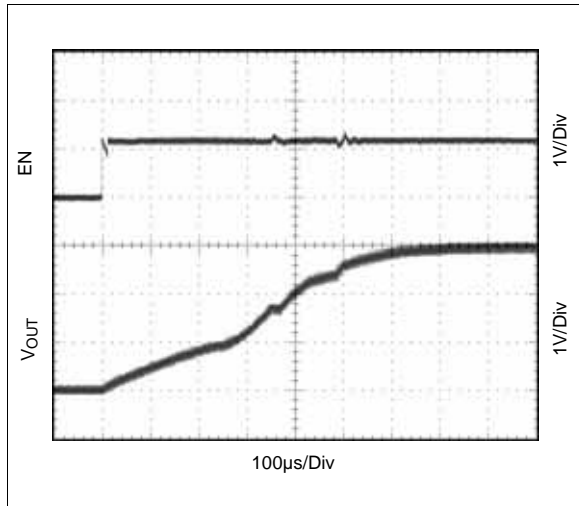
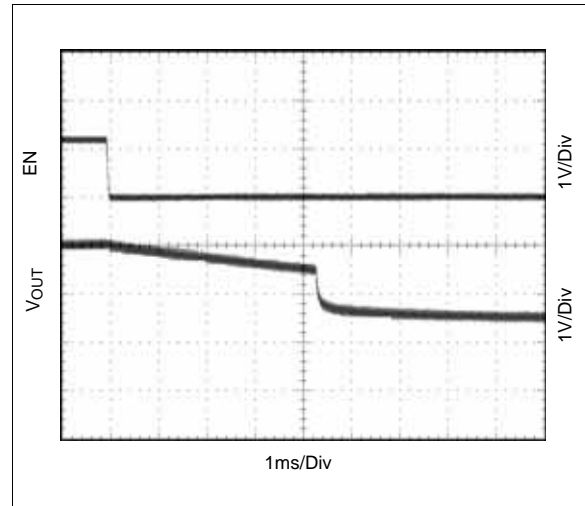
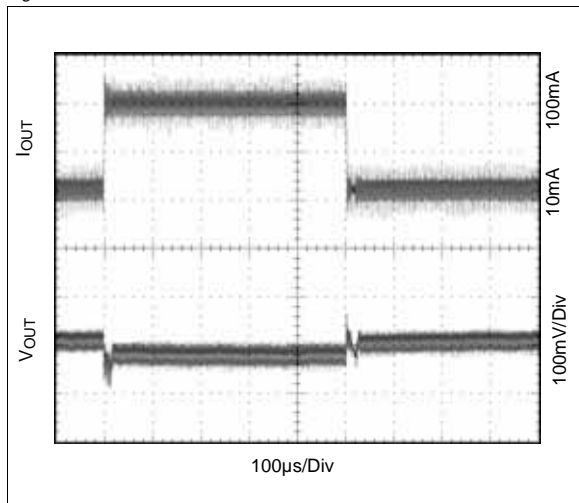
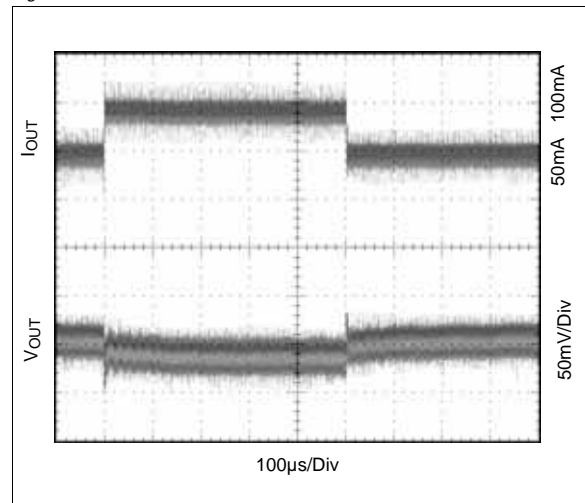

Figure 15. Startup,  $V_{OUT} = 3V$ ,  $I_{OUT} = 1mA$ Figure 16. Shutdown,  $V_{OUT} = 3V$ ,  $I_{OUT} = 1mA$ Figure 17. Load Transient,  $V_{OUT} = 3V$ Figure 18. Load Transient,  $V_{OUT} = 3V$ 

## 8 Detailed Description

The AS1330 can operate from a single-cell input voltage ( $V_{IN}$ ) below 1V, and features fixed frequency (4MHz) and current mode PWM control for exceptional line- and load-regulation. With low  $R_{DS(ON)}$  and gate charge internal NMOS and PMOS switches, the device maintains high-efficiency from light to heavy loads.

Modern portable devices frequently spend extended time in low-power or standby modes, switching to high power-drain only when certain functions are enabled. The AS1330 is ideal for portable devices since it maintain high-power conversion efficiency over a wide output power range, thus increasing battery life in these types of devices.

In addition to high-efficiency at moderate and heavy loads, the AS1330 includes an automatic powersave mode that improves efficiency of the power converter at light loads. The powersave mode is initiated if the output load current falls below a factory programmed threshold.

Figure 19. AS1330 - Block Diagram

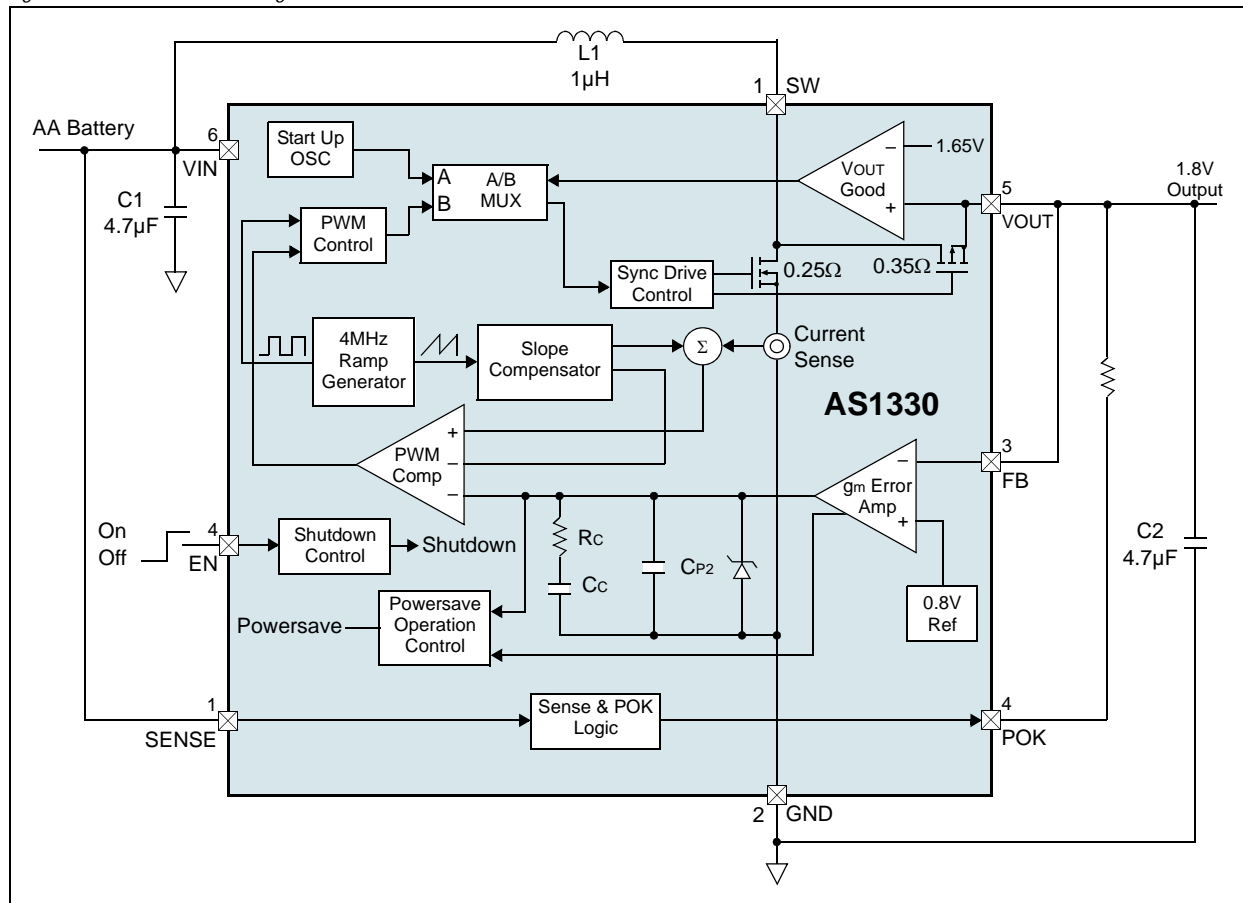

### Low-Voltage Start-Up

The AS1330 requires  $V_{IN}$  of only 0.85V (typ) or higher to start up. The low-voltage start-up circuitry controls the internal NMOS switch up to a maximum peak inductor current of 650mA (typ), with 1.5ms (approx.) off-time during start-up, allowing the devices to start up into an output load. With a  $V_{OUT} > 1.65V$ , the start-up circuitry is disabled and normal fixed-frequency PWM operation is initiated. In this mode, the AS1330 operates independent of  $V_{IN}$ , allowing extended operating time as the battery can drop to several tenths of a volt without affecting output regulation. The limiting factor for the application is the ability of the battery to supply sufficient energy to the output.

### Low-Noise Fixed-Frequency Operation

#### Oscillator

The AS1330 switching frequency is internally fixed at 4MHz allowing the use of very small external components.

### Current Sensing

A signal representing the internal NMOS-switch current is summed with the slope compensator. The summed signal is compared to the error amplifier output to provide a peak current control command for the PWM. Peak switch current is limited to approximately 650mA independent of VIN or VOUT.

### Zero Current Comparator

The zero current comparator monitors the inductor current to the output and shuts off the PMOS synchronous rectifier once this current drops to 20mA (approx.). This prevents the inductor current from reversing polarity and results in improved converter efficiency at light loads.

### Anti-Ringing Control

Anti-ringing control circuitry prevents high-frequency ringing on pin SW as the inductor current approaches zero. This is accomplished by damping the resonant circuit formed by the inductor and the capacitance on pin SW (Csw).

### Powersave Operation

In light load conditions, the integrated powersave feature removes power from all circuitry not required to monitor VOUT. When VOUT has dropped approximately 1% from nominal, the device powers up and begins normal PWM operation.

C2 recharges, causing the AS1330 to re-enter powersave mode as long as the output load remains below the powersave threshold. The frequency of this intermittent PWM is proportional to load current; i.e., as the load current drops further below the powersave threshold, the AS1330 turns on less frequently. When the load current increases above the powersave threshold, the AS1330 will resume continuous, seamless PWM operation.

### Notes:

1. An optional capacitor (CFF) between pins VOUT and FB in some applications can reduce VOUTp-p ripple and input quiescent current during powersave mode. Typical values for CFF range from 15 to 220pF.
2. In powersave mode the AS1330 draws only 30µA from the output capacitor(s), greatly improving converter efficiency.

### Shutdown

When pin EN is low the AS1330 is switched off and <1µA current is drawn from the battery; when pin EN is high the device is switched on. If EN is driven from a logic-level output, the logic high-level (on) should be referenced to VOUT to avoid intermittently switching the device on. In shutdown the battery input is disconnected from the output.

### Thermal Overload Protection

To prevent the AS1330 from short-term misuse and overload conditions the chip includes a thermal overload protection. To block the normal operation mode the device is turning the PFET and the NFET off in PWM mode as soon as the junction temperature exceeds 150°C. To resume the normal operation the temperature has to drop below 140°C.

**Note:** Continuing operation in thermal overload conditions may damage the device and is considered bad practice.

## 9 Application Information

The AS1330 is ideal for space critical applications where ultra-small size is critical as in medical diagnostic equipment, hand-held instruments, digital cameras, MP3 players, GPS receivers, and PC or Memory cards.

Along with [Figure 1 on page 1](#), [Figure 20](#), [Figure 21](#) and [Figure 22 on page 11](#) depict a few of the many applications for which the AS1330 converters are perfectly suited.

### Adjustable Output Voltage

The integrated error amplifier is an internally compensated trans-conductance ( $g_m$ ) type (current output). The internal 0.8V reference voltage is compared to the voltage at pin FB to generate an error signal at the output of the error amplifier. A voltage divider from VOUT to GND programs the output voltage from 1.8 to 3.0V via pin FB as:

$$V_{OUT} = 0.8V(1 + (R_1/R_2)) \quad (EQ 1)$$

### Sense Function

The AS1330 offers a sense function for monitoring a voltage (e.g.: the battery voltage). The sense function can work in three different modes:

- SENSE to GND: The POK is related to VOUT (see [Figure 22 on page 11](#)).
- SENSE to VIN: If the pin SENSE is directly connected to pin VIN, the internal reference voltage (0.8V) is used to compare it with VIN. The POK goes high when the voltage on SENSE is above 0.8V and low when the voltage on SENSE is below 0.8V (see [Figure 21 on page 11](#)).
- SENSE to a voltage divider: With the voltage divider the threshold voltage on which the POK reacts can be set. If the monitored voltage is higher then the user set threshold voltage the POK is high, when the monitored voltage is lower the POK goes low (see [Figure 20](#)). The threshold voltage can be set with the following equation:

$$V_{threshold} = 0.8V(1 + (R_{IN1}/R_{IN2})) \quad (EQ 2)$$

Figure 20. AS1330 - Boost Converter, Single AA Cell to 3.0V fixed Output Voltage

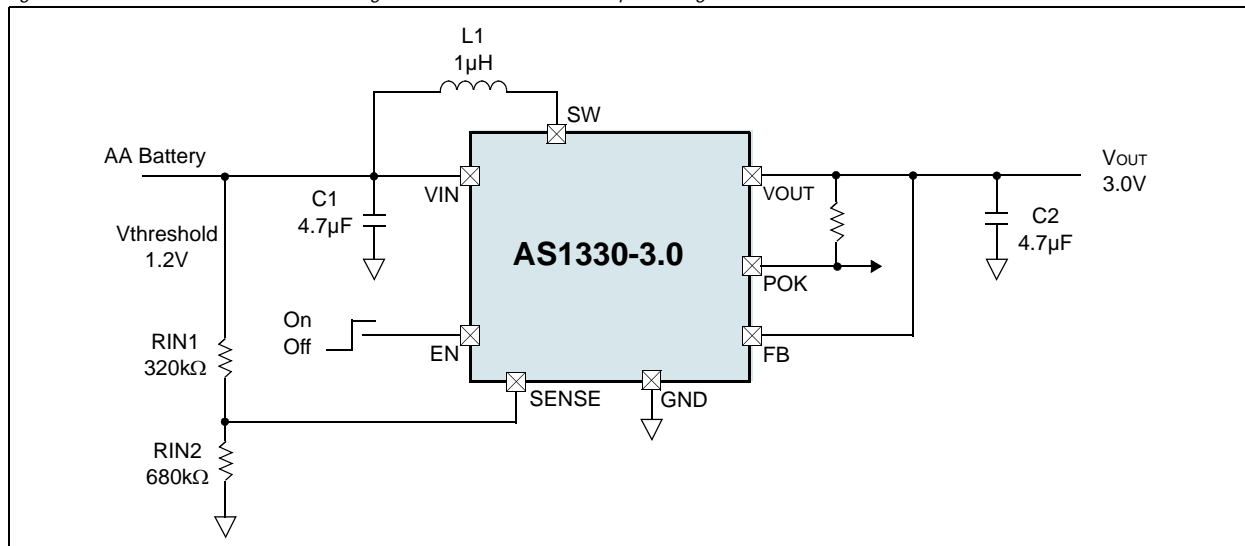
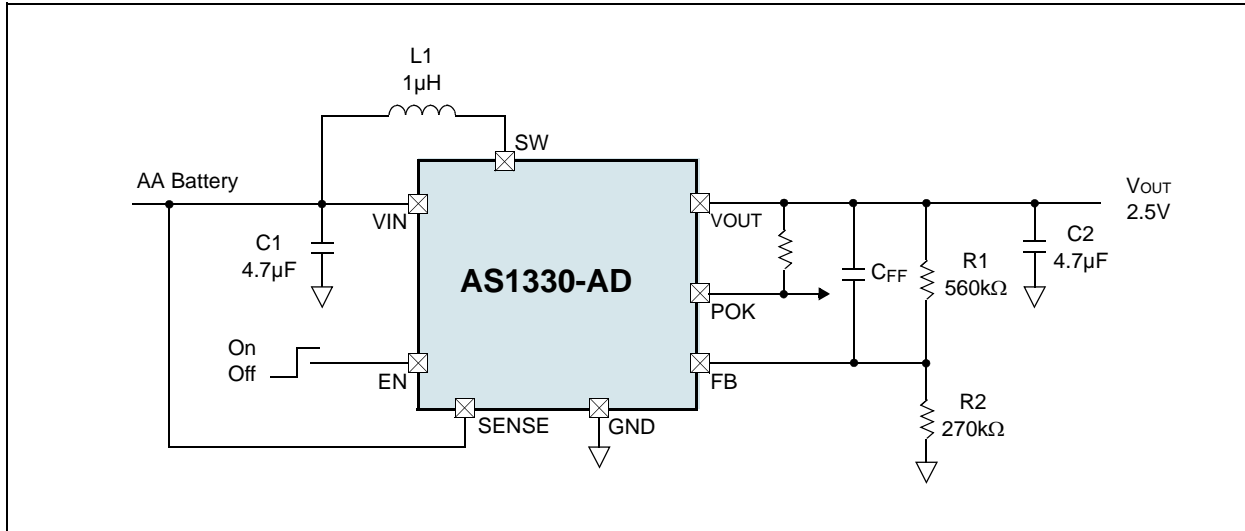
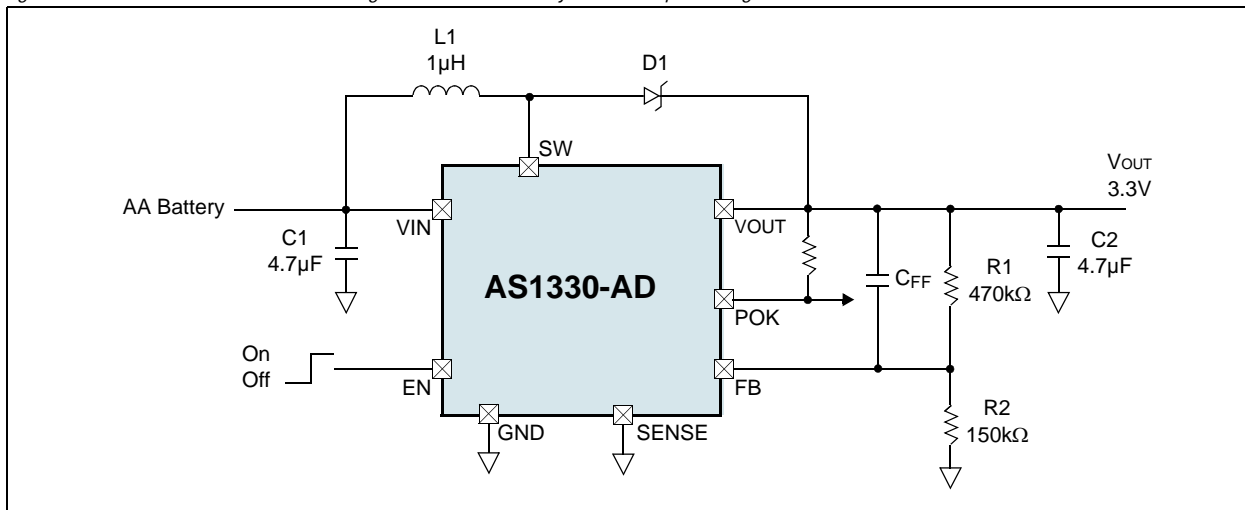

Figure 21. AS1330 - Boost Converter, Single AA Cell to 2.5V adjustable Output Voltage



To power an output voltage of 3.3V with the AS1330 a schottky diode is required. In this setup the output disconnect function is no longer working because the schottky diode is bypassing the input to the output.

Figure 22. AS1330 - Boost Converter, Single AA Cell to 3.3V adjustable Output Voltage



## Smallest Layout

Due to the high switching frequency, the small package and the minimal count of external components, the overall DC-DC system requires only 6.6x6.6mm of PCB space (see Figure 23).

Figure 23. Layout Consideration

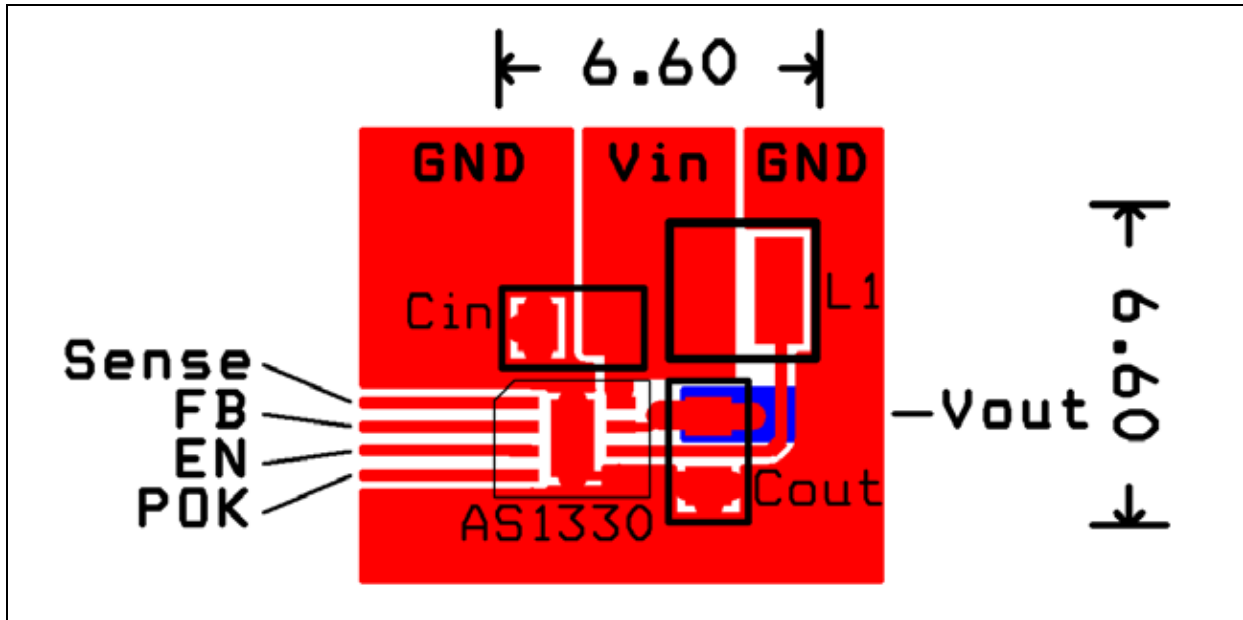

## Component Selection

Only three power components are required to complete the design of the boost converter, except the additional two resistors for the voltage divider to set  $V_{OUT}$ . The high operating frequency and low peak currents of the AS1330 allow the use of low value, low profile inductors and tiny external ceramic capacitors.

### Inductor Selection

The inductor should have low ESR to reduce the  $I^2R$  power losses, and must be able to handle the peak inductor current without saturating. High-frequency ferrite core inductor materials reduce frequency dependent power losses compared to less expensive powdered iron types, which result in improved converter efficiency.

A 1 $\mu$ H inductor with a >850mA current rating and low DCR is recommended. For applications where radiated noise is a concern, a toroidal or shielded inductor can be used.

### Capacitor Selection

A 4.7 $\mu$ F capacitor is recommended for C1 and for C2. Small-sized ceramic capacitors are recommended. X5R and X7R ceramic capacitors are recommended as they retain capacitance over wide ranges of voltages and temperatures.

#### Output Capacitor Selection

Low ESR capacitors should be used to minimize  $V_{OUT}$  ripple. Multi-layer ceramic capacitors are recommended since they have extremely low ESR and are available in small footprints. Up to 10 $\mu$ F output capacitor is sufficient for most applications. Larger values up to 22 $\mu$ F may be used to obtain extremely low output voltage ripple and improve transient response.

An additional phase lead capacitor may be required with output capacitors larger than 10 $\mu$ F to maintain acceptable phase margin. X5R and X7R dielectric materials are recommended due to their ability to maintain capacitance over wide voltage and temperature ranges.

#### Input Capacitor Selection

Low ESR input capacitors reduce input switching noise and reduce the peak current drawn from the battery. Ceramic capacitors are recommended for input decoupling and should be located as close to the device as is practical. A 4.7 $\mu$ F input capacitor is sufficient for most applications. Larger values may be used without limitations.

Table 4. Recommended External Components

Name	Part Number	Value	Rating	Type	Size	Manufacturer
C1, C2	GRM219R60J106KE19	10 $\mu$ F	6.3V	X5R	0805	Murata <a href="http://www.murata.com">www.murata.com</a>
	GRM188R60J475KE19	4.7 $\mu$ F	6.3V	X5R	0603	
L1	LQH32PN1R0NN0	1 $\mu$ H	2.05A	45m $\Omega$	3.2x2.5x1.55mm	Coilcraft <a href="http://www.coilcraft.com">www.coilcraft.com</a>
	LQH32PNR47NN0	470nH	2.55A	30m $\Omega$	3.2x2.5x1.55mm	
	EPL2010-102ML	1 $\mu$ H	1.35A	99m $\Omega$	2.0x2.0x1.0mm	
	EPL2010-821ML	820nH	1.6A	68m $\Omega$	2.0x2.0x1.0mm	
	EPL2010-471ML	470nH	2.2A	40m $\Omega$	2.0x2.0x1.0mm	

### Diode Selection

A Schottky diode should be used to carry the output current for the time it takes the PMOS synchronous rectifier to switch on. For  $V_{OUT} > 3.0V$  a schottky diode is mandatory, for  $V_{OUT} \leq 3.0V$  it is optional, although using one will increase device efficiency by 2 to 3%. On one hand the schottky diode reduces the overshoot on the output signal but on the other hand the output disconnect function is no longer working.

**Note:** Do not use ordinary rectifier diodes, since the slow recovery times will compromise efficiency.

## 10 Package Drawings and Markings

Figure 24. TDFN (2x2mm) 8-pin Marking

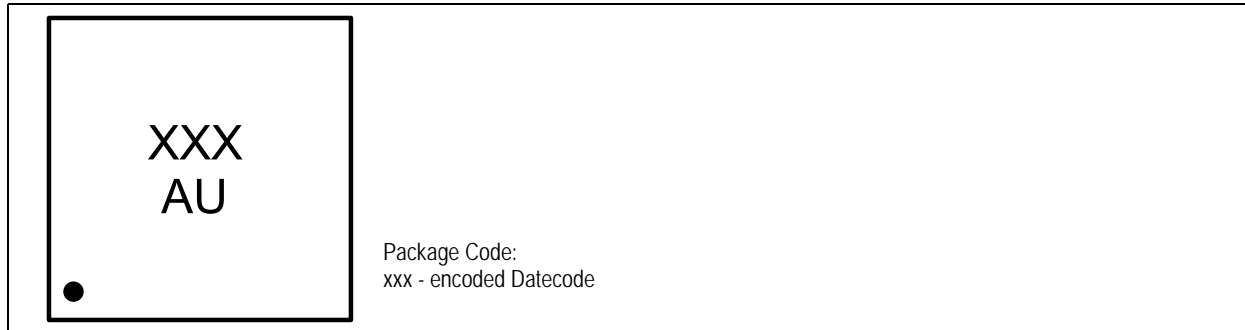
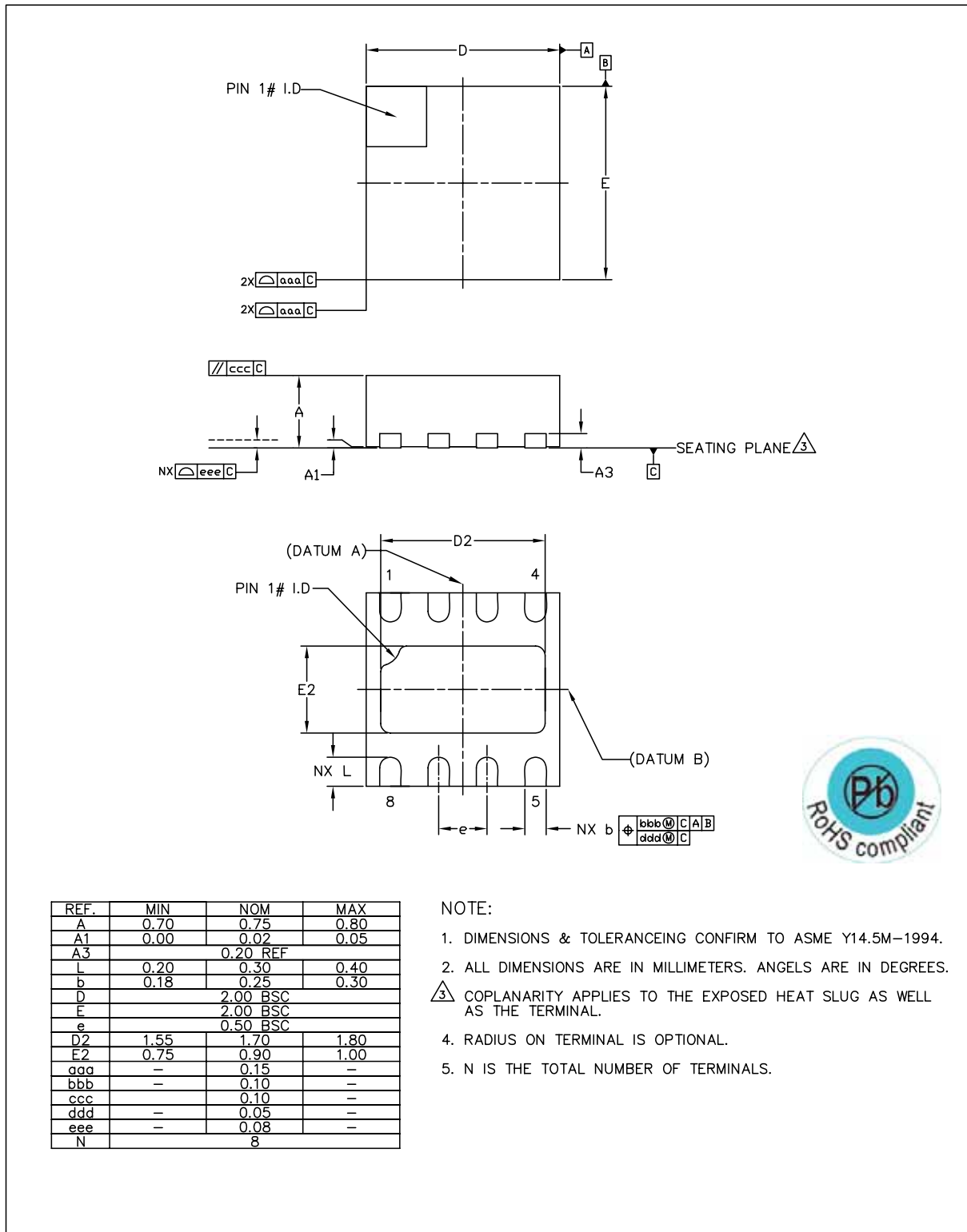

Figure 25. TDFN (2x2mm) 8-pin Package



REF.	MIN	NOM	MAX
A	0.70	0.75	0.80
A1	0.00	0.02	0.05
A3		0.20 REF	
L	0.20	0.30	0.40
b	0.18	0.25	0.30
D		2.00 BSC	
E		2.00 BSC	
e		0.50 BSC	
D2	1.55	1.70	1.80
E2	0.75	0.90	1.00
aaa	-	0.15	-
bbb	-	0.10	-
ccc	-	0.10	-
ddd	-	0.05	-
eee	-	0.08	-
N		8	

NOTE:

1. DIMENSIONS & TOLERANCEING CONFIRM TO ASME Y14.5M-1994.
2. ALL DIMENSIONS ARE IN MILLIMETERS. ANGELS ARE IN DEGREES.
3. COPLANARITY APPLIES TO THE EXPOSED HEAT SLUG AS WELL AS THE TERMINAL.
4. RADIUS ON TERMINAL IS OPTIONAL.
5. N IS THE TOTAL NUMBER OF TERMINALS.

austriamicrosystems a leap ahead in analog			ASSEMBLY ENGINEERING	
DRAWN RHS	DATE 2010.12.29	REV. N/C	TITLE MLPDP 2x2x0.75mm 8 LEAD, 1.70X0.90mm ePAD	REFERENCE DOCUMENT JEDEC MO - 229 LATEST REVISION
CHECKED GBO	DATE 2010.12.29		DRAWING NO. QGf	UNIT
APPROVED MKR	DATE 2010.12.29	SHEET 1 OF 1	DIMENSION AND TOLERANCE	SCALE NOT IN SCALE

## 11 Ordering Information

The device is available as the standard products listed in [Table 5](#).

*Table 5. Ordering Information*

Ordering Code	Marking	Output	Description	Delivery Form	Package
AS1330-BTDT-AD	AV	adjustable	4MHz, Low Voltage, DC-DC Step-Up Converter	Tape and Reel	TDFN (2x2mm) 8-pin
AS1330-BTDT-18	AU	1.8V	4MHz, Low Voltage, DC-DC Step-Up Converter	Tape and Reel	TDFN (2x2mm) 8-pin
AS1330-BTDT-30	AZ	3.0V	4MHz, Low Voltage, DC-DC Step-Up Converter	Tape and Reel	TDFN (2x2mm) 8-pin

**Note:** All products are RoHS compliant.

Buy our products or get free samples online at ICdirect: <http://www.austriamicrosystems.com/ICdirect>

For further information and requests, please contact us <mailto:sales@austriamicrosystems.com>  
or find your local distributor at <http://www.austriamicrosystems.com/distributor>

## Copyrights

Copyright © 1997-2011, austriamicrosystems AG, Tobelbaderstrasse 30, 8141 Unterpremstaetten, Austria-Europe. Trademarks Registered ®. All rights reserved. The material herein may not be reproduced, adapted, merged, translated, stored, or used without the prior written consent of the copyright owner.

All products and companies mentioned are trademarks or registered trademarks of their respective companies.

## Disclaimer

Devices sold by austriamicrosystems AG are covered by the warranty and patent indemnification provisions appearing in its Term of Sale. austriamicrosystems AG makes no warranty, express, statutory, implied, or by description regarding the information set forth herein or regarding the freedom of the described devices from patent infringement. austriamicrosystems AG reserves the right to change specifications and prices at any time and without notice. Therefore, prior to designing this product into a system, it is necessary to check with austriamicrosystems AG for current information. This product is intended for use in normal commercial applications. Applications requiring extended temperature range, unusual environmental requirements, or high reliability applications, such as military, medical life-support or life-sustaining equipment are specifically not recommended without additional processing by austriamicrosystems AG for each application. For shipments of less than 100 parts the manufacturing flow might show deviations from the standard production flow, such as test flow or test location.

The information furnished here by austriamicrosystems AG is believed to be correct and accurate. However, austriamicrosystems AG shall not be liable to recipient or any third party for any damages, including but not limited to personal injury, property damage, loss of profits, loss of use, interruption of business or indirect, special, incidental or consequential damages, of any kind, in connection with or arising out of the furnishing, performance or use of the technical data herein. No obligation or liability to recipient or any third party shall arise or flow out of austriamicrosystems AG rendering of technical or other services.



## Contact Information

Headquarters  
austriamicrosystems AG  
Tobelbaderstrasse 30  
A-8141 Unterpremstaetten, Austria  
Tel: +43 (0) 3136 500 0  
Fax: +43 (0) 3136 525 01

For Sales Offices, Distributors and Representatives, please visit:  
<http://www.austriamicrosystems.com/contact>