

AS3543

Preliminary Product Brief

High End Stereo Audio Codec with System PMU

General Description

The AS3543 is an ultra low power stereo audio codec and is designed for Portable Digital Audio Applications.

It allows high-end quality playback with up to 100dBa SNR and recording in FM quality. With one microphone (including pre-amplifier and supply for an electret microphone) and two line inputs, it allows connecting a variety of audio inputs. The different audio signals can be mixed via a 6-channel mixer and fed to either a headphone output for 16 /32 headsets or a line output. Both outputs have a ground noise cancellation to use it e.g. in car docking stations. The audio outputs have also an auto fading implemented which performs the fade-in, fade-out as well as the transition between specific volume levels automatically with an selectable timing.

Further the device offers advanced power management functions. All necessary ICs and peripherals in a Digital Audio Player are supplied by the AS3543. It features 2 DCDC converters for core and memory/periphery supply as well as 4 LDOs. Both DCDC converter feature DVM (dynamic voltage management) with an selectable timing for the voltage stepping. The different regulated supply voltages are programmable via the serial control interface.

The step-up converter for the backlight can operate up to 25V (with an external transistor even higher) in voltage and current control mode. An internal voltage protection is limiting the output voltage in the case of external component failures. 2 high voltage current sinks can be used to operate two , if needed also unbalanced, LED strings. An automatic dimming function allows a logarithmic on/off of the backlight with selectable timing.

AS3543 also contains a Li-Ion battery charger with constant current, constant voltage and trickle charging. The maximum charging current is 460mA. An integrated battery switch is separating the battery during charging or whenever an external power supply is present. With this switch it is also possible to operate with no or deeply discharged batteries.

The AS3543 has an on-chip, phase locked loop (PLL) which generates the needed internal CODEC master clock. I2S Frame and shift-clock have to be applied from the processor for playback and recording.

Further the AS3543 has an independent 32kHz real time clock (RTC) on chip which allows a complete power down of the system CPU while only consuming less than 1µA. An internal switch automatically switches between the RTC backup-battery and main battery supply.

The single supply voltage may vary from 2.7V (2.4V) to 5.5V.

Key Features

Audio

Audio power consumption:

- - 5mW: 96dB DAC to Headphone @ 1.8V, 32Ω
- - 7mW: 100dB DAC to Headphone @ 2.9V, 32Ω

Sigma Delta Converters

- DAC
 - 98dB SNR ('A' weighted) @ 1.8V
 - 102dB SNR ('A' weighted) @ 2.9V
- ADC
 - 83dB SNR ('A' weighted) @ 1.8V
- Sampling Frequency
 - DAC: 8-48kHz
 - ADC: 8-24kHz

High Efficiency Headphone Amplifier

- volume control via serial interface
- 32 steps @1.5dB and MUTE
- 2x12mW @16 driver capability@ 1.8V supply
- THD -74dB @16Ω; 1.8V
- 2x40mW @16 driver capability@ 2.9V supply
- THD -77dB @16Ω; 2.9V
- headphone and over-current detection
- phantom ground eliminates large capacitors
- ground noise cancellation

Line Output

- volume control via serial interface
- 32 steps @1.5dB and MUTE
- 0.6Vp @10kΩ
- ground noise cancellation



Microphone Input

- 3 gain pre-setting (28dB/34dB/40dB) and AGC
- 2 gain steps @1.5dB and MUTE
- supply for electret microphone
- microphone detection
- remote control by switch

2 Line Inputs

- volume control via serial interface
- 32 steps @1.5dB and MUTE
- stereo or 2x mono

Audio Mixer

- 6 channel input/output mixer with AGC
- mixes line inputs and microphone with DAC
- left and right channels independent

Power Management

Voltage Generation

- step down for CPU core (0.61V-3.35V, 250mA)
- step down for peripheral (0.61V-3.35V, 250mA)
- LDO1 for AFE supply (1.7V (1.65-3.2V), 50mA)
- LDO2 for AFE supply (2.7V (2.3-3.5V), 200mA)
- LDO3 for peripherals (1.2V-3.5V, 100/200mA)
- LDO4 for peripherals (1.2V-3.5V, 100/200mA)
- VBUS comparator
- separate input for LDO3
- power supply supervision & hibernation modes
- 5sec and 10sec emergency shut-down

Backlight Driver

- step up for backlight (25V)
- current control mode (1.2-36mA)
- voltage control mode
- 2 current sinks
- automatic dimming
- over-voltage protection

Battery Charger

- automatic trickle charge (55mA)
- prog. constant current charging (55-460mA)
- prog. constant voltage charging (3.9V-4.25V)
- current limitation for USB mode
- integrated battery switch

General

Supervisor

- automatic battery monitoring with interrupt generation and selectable warning level
- automatic temperature monitoring with interrupt generation and selectable warning and shutdown levels

Real Time Clock

- ultra low power 32kHz oscillator
- 32bit RTC sec counter, 96 days auto wake-up
- selectable alarm (seconds or minutes)
- 128bit free SRAM for random settings
- 32kHz clock output to peripheral
- voltage generation
- trim able oscillator
- <1uA total power consumption

Auxiliary Oscillator (system clock generation)

- low power 12-24MHz oscillator
- clock output

General Purpose ADC

- 10bit resolution
- 19 inputs analog multiplexer

Interfaces

- 2 wire serial control interface
- reset pin with selectable delay, power good pin
- 64bit unique ID (OTP)
- 22 different interrupts
- Package CTBGA68 [6.0x6.0x1.1mm] 0.5mm pitch

Applications

Portable Digital Audio/Video Player and Recorder
PDA, Smartphone

Figure 1. Block Diagram

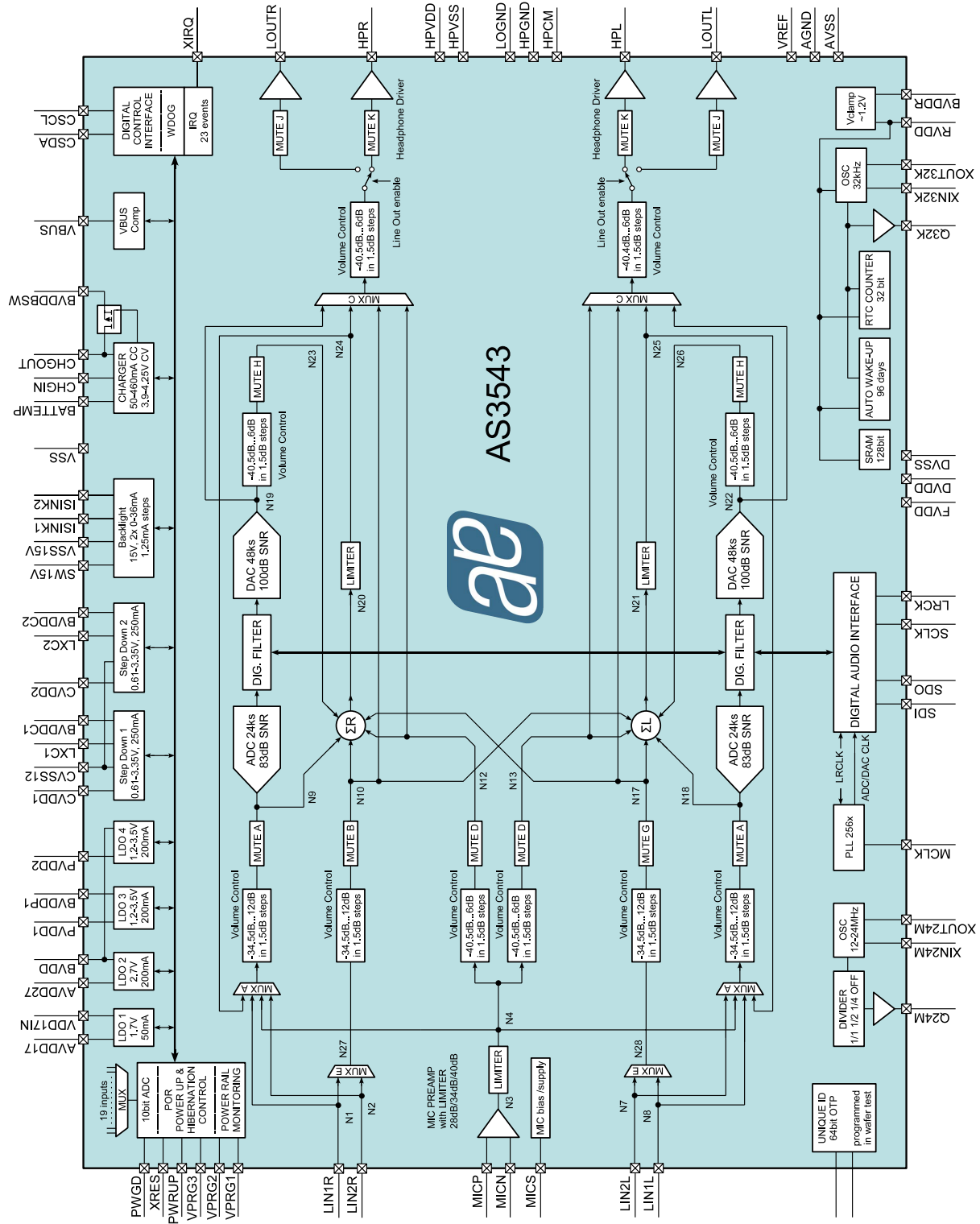

Copyrights

Copyright © 1997-2007, austriamicrosystems AG, Schloss Premstaetten, 8141 Unterpemstaetten, Austria-Europe. Trademarks Registered ®. All rights reserved. The material herein may not be reproduced, adapted, merged, translated, stored, or used without the prior written consent of the copyright owner.

All products and companies mentioned are trademarks or registered trademarks of their respective companies.

Disclaimer

Devices sold by austriamicrosystems AG are covered by the warranty and patent indemnification provisions appearing in its Term of Sale. austriamicrosystems AG makes no warranty, express, statutory, implied, or by description regarding the information set forth herein or regarding the freedom of the described devices from patent infringement. austriamicrosystems AG reserves the right to change specifications and prices at any time and without notice. Therefore, prior to designing this product into a system, it is necessary to check with austriamicrosystems AG for current information. This product is intended for use in normal commercial applications. Applications requiring extended temperature range, unusual environmental requirements, or high reliability applications, such as military, medical life-support or life-sustaining equipment are specifically not recommended without additional processing by austriamicrosystems AG for each application. For shipments of less than 100 parts the manufacturing flow might show deviations from the standard production flow, such as test flow or test location.

The information furnished here by austriamicrosystems AG is believed to be correct and accurate. However, austriamicrosystems AG shall not be liable to recipient or any third party for any damages, including but not limited to personal injury, property damage, loss of profits, loss of use, interruption of business or indirect, special, incidental or consequential damages, of any kind, in connection with or arising out of the furnishing, performance or use of the technical data herein. No obligation or liability to recipient or any third party shall arise or flow out of austriamicrosystems AG rendering of technical or other services.



Contact Information

Headquarters

austriamicrosystems AG
A-8141 Schloss Premstaetten, Austria

Tel: +43 (0) 3136 500 0
Fax: +43 (0) 3136 525 01

For Sales Offices, Distributors and Representatives, please visit:

<http://www.austriamicrosystems.com/contact>