

## Technical Article

# Automotive Battery Management

## New sensing topology enables high-side sensing of a 12V automotive battery at mA resolution over a >1kA range

**By Manfred Brandl**  
**Product Manager, austriamicrosystems AG**

To improve the fuel economy of new vehicles, more and more functions within a car are being electrified, thus reducing the continuous load on the internal combustion engine. Such functions include water, oil and fuel pumps, valve actuation and power steering. As the power load is shifted from the engine to the vehicle's battery, the requirement to keep the battery charged and functioning correctly becomes ever more critical.

For the designer of automotive electrical systems, the battery sensor is a crucial component: it is used to provide state of charge, state of health and state of function readings via a LIN bus to the electrical system's Electronic Control Unit (ECU).

Traditionally, a battery sensor is placed at the negative pole of the battery, where it measures low-side current, voltage and temperature. A battery sensor works by simultaneously capturing battery current and battery voltage values at a sampling rate of 1kHz. Extreme accuracy is required for measurement of the state of charge, and to dynamically track battery impedance. Shunt-based low-side current sensing with a zero-offset high-precision measurement system operating in sync with a voltage sensing function provides the required accuracy at virtually zero insertion loss. It is suitable for the harsh automotive environment.

What if, however, the battery sensor were placed at the positive pole, operating as a high-side sensor? Vehicle designers would gain the ability to change and optimize control network topologies, for instance by using the battery sensor to measure various parts of the electrical supply system. It could also be combined with related modules, such as the power distribution box, and interfaced to a shared microcontroller, thus offering the potential to reduce Bill of Materials (BOM) costs. This would also support the trend to design vehicles with fewer, more centralized ECUs.

It would theoretically be possible to move an existing low-side battery sensor over to the high side either by using a charge pump and level-shifting technique to raise the sensor's power supply to a level above the battery's 12V, or to use galvanically isolated power and digital communications components. The first approach, however, would be plagued by power pulses that would require sophisticated and difficult EMC counter-measures. The second would require the use of expensive isolated components that have reliability and power-consumption question marks against them.

Now, however, a new approach to automotive battery sensing developed by austriamicrosystems offers the possibility of implementing high-side battery sensing with the accuracy, precision and robustness required by vehicle manufacturers. It ensures highly accurate signal pick-up from a 10089 shunt at the battery's high side to cover currents ranging from 1mA to more than 1kA with virtually no insertion loss. What is more, it enables standby current, voltage and temperature monitoring modes at very low current draw (around 808A) – a crucial requirement in automotive battery sensors, which are never disconnected from the battery in normal operation.

Its implementation raises no EMC difficulties, since EMC events are cut out via common-mode suppression and ADC filters, and the system's output can be routed to an existing ECU, thus reducing BOM cost.

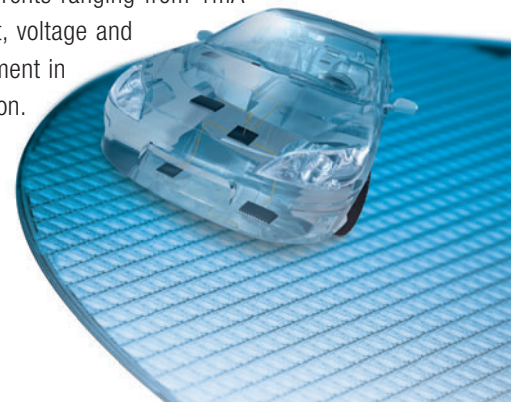

# Automotive Battery Management

## Shunt resistor specification

The description in this article is focussed on the signal conditioning, power management and communication layers of the sensor. Current sensing requires the use of a low-insertion-loss 10089 shunt connected to the positive battery terminal in series with the load (see Figure 1).

As stated above, the demanding specifications for automotive battery sensors include a requirement for very high accuracy. Clearly, then, the temperature drift at the shunt resistor must be extremely low, as any drift in the resistance value of the shunt directly affects the current readings generated by the sensor.

For this reason, the austriamicrosystems circuit described here uses a 10089 BAS shunt from Isabellenhuetten (www.isabellenhuetten.de). This shunt type uses Manganin alloy as the resistive element. Its temperature coefficient is not only low; just as important, its Seebeck coefficient is similar to that of copper. This means that the signal generation attributable to thermocouple effects when inserted into a copper rail is negligible. The shunt's change in resistance value over time is also both minimal and predictable.

## Extremely wide measurement range

The most challenging aspect of the design of an automotive battery sensor is the need for very precise measurement over a very wide current range – 1mA to 1kA. This requires a sensor interface with a measurement range of >100mV, with a resolution of better than 18V.

The key attributes of such a measurement system are:

- Very low noise
- Highly linear
- Zero offset

Offset-free measurement systems usually make use of a continuous offset-cancellation technique. In the high-side battery sensor solution presented here, auto zero offset is achieved by a sequence of signal-conditioning functions:

- chopping the analogue sensor signal
- amplifying and level-shifting the chopped signals
- digitising them
- de-chopping in the digital domain

This architecture enables the offset and the low-frequency noise components of the entire measurement path of the sensor interface to be cancelled.

As Figure 1 shows, the analogue signal chopper is located at the AS8525's input pads, which receive the shunt signal at a nominal 14V common-mode input voltage. The chopped signal is amplified by the device's Programmable Gain Amplifier (PGA), level-shifted to a low common-mode voltage and forwarded to the AS8510 Analogue-to-Digital Converter (ADC). (In this application, the AS8510's internal chopper must be disabled and the PGA bypassed.) A dedicated Chop\_Clock pin must be enabled to support the synchronisation of the averaging and chopping functions.

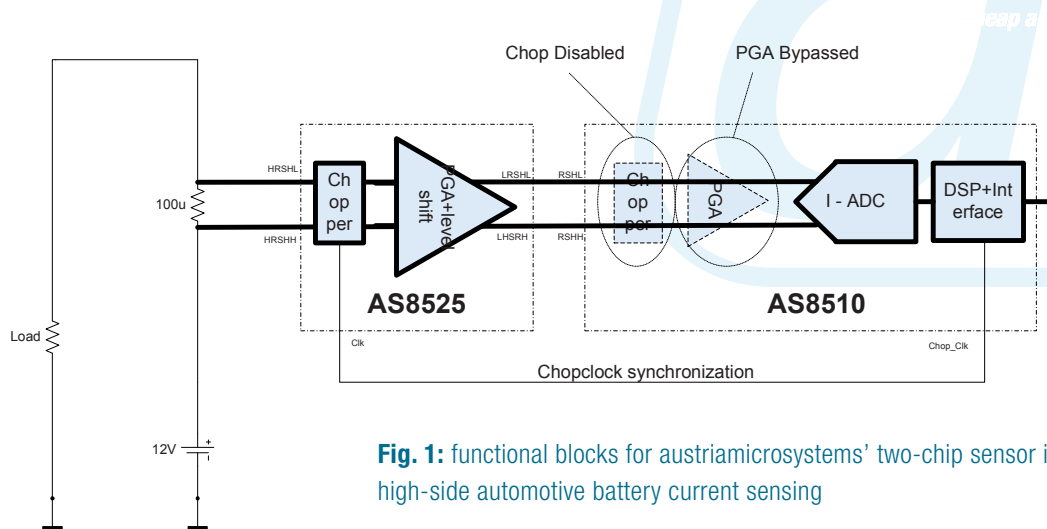

Fig. 1: functional blocks for austriamicrosystems' two-chip sensor interface for high-side automotive battery current sensing

For voltage measurement, the battery's voltage is attenuated by a precision resistive attenuator inside the AS8525 and forwarded to the second data acquisition channel of the AS8510 in differential form (see Figure 2). This channel can be multiplexed with input channels for either an external or internal temperature sensor.

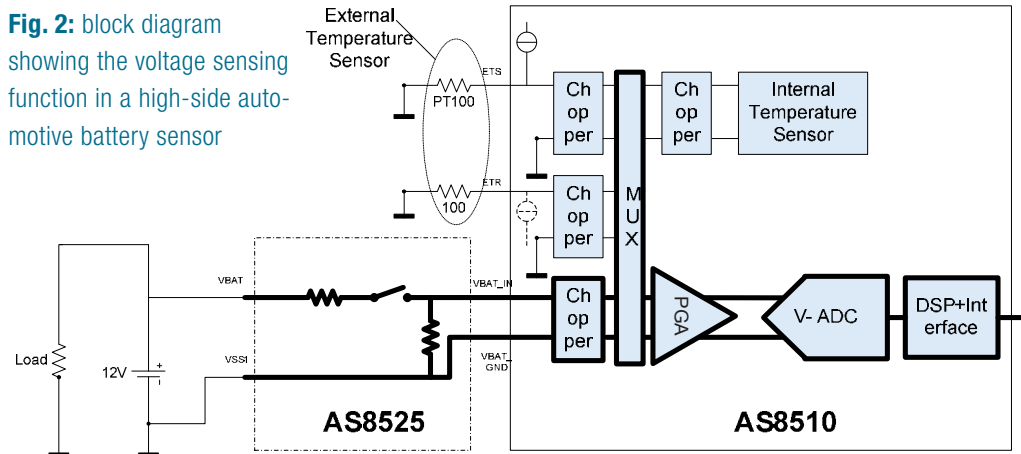
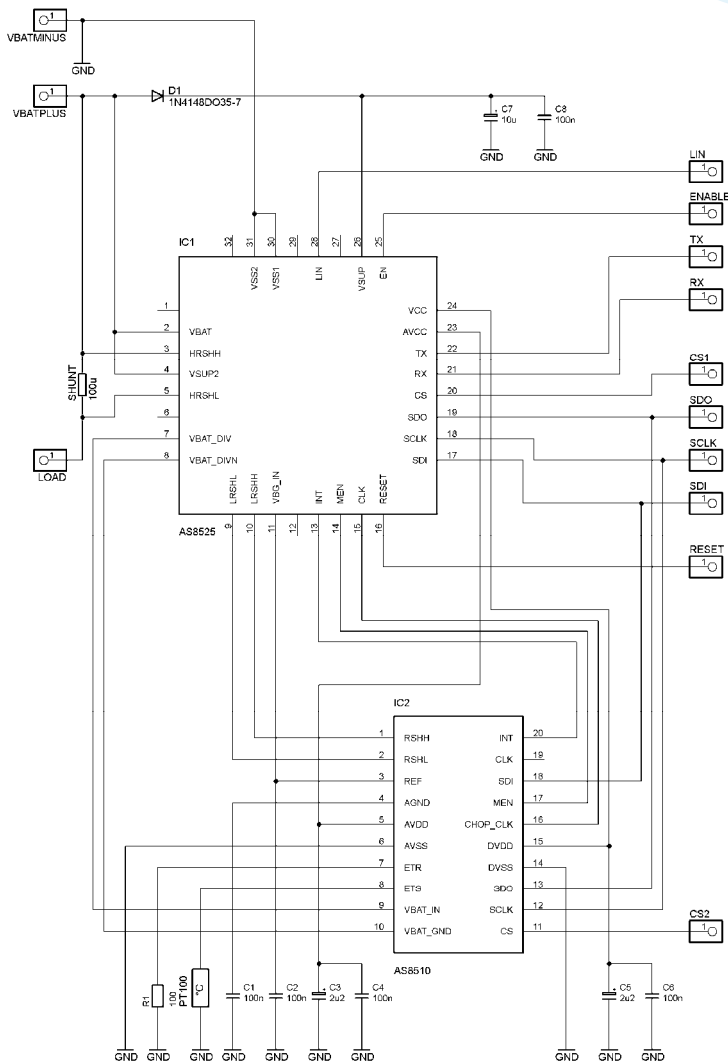

Fig. 2: block diagram showing the voltage sensing function in a high-side automotive battery sensor

From the partitioning of the functional blocks, it can be seen that every function related to the actual battery voltage takes place inside the AS8525, but that low voltage signal-conditioning functions take place inside the AS8510. The AS8525, which is manufactured in 0.358μm 60V CMOS technology, also provides two low dropout voltage regulators (LDOs) with power-on reset and voltage supervision, a LIN bus transceiver and the precision voltage attenuator. System designers have the option of using the two independent LDOs in the AS8525 to separate the analogue signals from the digital part of the AS8510 and the microcontroller.

For temperature sensing there are two options: if the sensor is placed at the battery pole, the AS8510's internal temperature sensor can be used to pick up the battery temperature through the pole, shunt and PCB. The other option, if the sensor's electronics are located away from the battery in a separate compartment, is to use an external temperature sensor.

The large common-mode input signal produces current measurement error of typically 0.05%/V. As the commonmode input signal for the shunt is the same as the battery voltage, and the battery voltage is measured in sync with the current, this error can be corrected in software in the external microcontroller. An accurate value for commonmode error can be captured through end-of-line calibration: apply a reference current at two different commonmode shunt voltages, measure the deviation and store this value as the calibration factor.



**Fig. 3:** circuit diagram, high-side automotive battery sensor implemented with the AS8525 and AS8510 from austriamicrosystems

A schematic of the entire high-side battery sensor with an SPI output to a microcontroller is shown in Figure 3. In terms of PCB design, the shunt should be connected with very short and symmetrical signal lines to HRSHH and HRSHL. Any kind of coupling from other sources must be avoided. Best results will be obtained by soldering the AS8525 and AS8510 directly to the shunt on the PCB. This can be done by heating the shunt from below with a hot plate until the solder liquefies.

For good EMC performance, all differential signal lines need to be as close together and as symmetrical as possible.

## Conclusion

The AS8510 + AS8525 chipset provides a signal conditioning, power management and communication layer for 12V high-side current, voltage and temperature sensing systems at a typical sample rate of 1kHz. Using a 10089 shunt, it offers resolution down to 2.5mA over a current range of 1,600A and at an accuracy of better than 1%. Voltage measurement accuracy is 12-bit or better.

Stand-by current is typically 808A in current-monitoring mode. It fully conforms with all applicable automotive standards. The chipset is load-dump protected up to 42V and offers reverse polarity protection at shunt inputs and the battery voltage sense input.

For more information on this high-side automotive battery sensing application, and on the AS8525 and AS8510, visit [www.austriamicrosystems.com](http://www.austriamicrosystems.com)

Author e-mail: [manfred.brandl@austriamicrosystems.com](mailto:manfred.brandl@austriamicrosystems.com)

