

# AS8530

## LIN Transceiver with Integrated Voltage Regulator and MCU Interface for Automotive Applications



### 1 General Description

The AS8530 is a general purpose companion IC for sensor and actuator LIN slaves offering LIN transceiver and low drop voltage regulator.

It also provides a 2-wire microcontroller interface through shared EN and TX pins to access a window watchdog with RC oscillator, control registers, backup registers and monitoring information.

The IC is fabricated in a high voltage CMOS technology which is able to withstand voltages up to 42V.

The product is available in ep-SOIC8 package.

- Typically 45µA quiescent current in standby mode, Typically 35µA quiescent current in sleep mode
- Under voltage reset with factory options
- LIN bus transceiver I conforming to LIN 2.1, TX time out fail safe feature, over temperature warning and shut down
- Window watchdog if factory enabled
- Micro controller 2-wire interface through shared pins for watchdog trigger, monitoring, register read /write
- Chip ID for traceability and module ID
- 8 Backup registers to store data during VCC shut down
- ep-SOIC8 package
- -40°C to +125°C ambient operating temperature

### 2 Key Features

- Operating voltage 6V to 18V
- Linear, low-drop voltage regulator: VCC = 5V ±5% or 3.3V ±5% as a factory programming option
- 50mA load current
- Operating modes: Normal and Standby or Normal and Sleep as a factory option

### 3 Applications

The AS8530 is a System Basis Chip for automotive LIN networked sensor or actuator slaves.

Figure 1. AS8530 LIN Transceiver Block Diagram

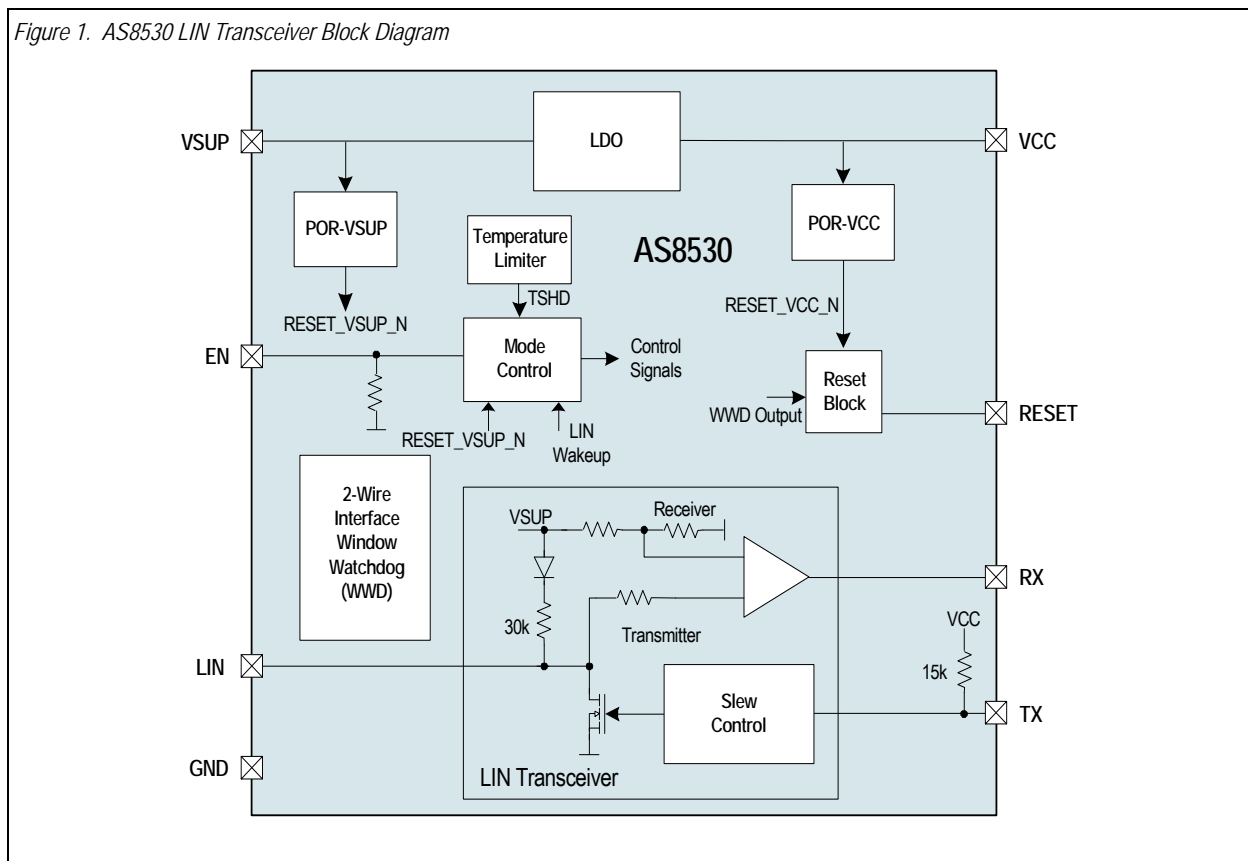

## Contents

1	General Description .....	1
2	Key Features.....	1
3	Applications.....	1
4	Pin Assignments .....	4
4.1	Pin Descriptions.....	4
5	Absolute Maximum Ratings .....	5
6	Electrical Characteristics.....	6
6.1	Operating Conditions.....	6
6.2	Digital Inputs and Outputs .....	6
6.3	Detailed System and Block Specifications .....	7
6.3.1	Electrical System Specifications .....	7
6.4	Low Dropout Regulator.....	7
6.5	LIN Transceiver .....	8
6.5.1	DC Electrical Characteristics .....	8
6.5.2	AC Electrical Characteristics .....	9
6.5.3	Temperature Limiter .....	10
6.5.4	TX Timeout Watchdog.....	10
6.6	VCC Undervoltage Reset and Window Watchdog.....	11
6.7	Two Port Serial Interface .....	12
7	Detailed Description.....	13
7.1	Voltage Regulator (LDO) .....	13
7.2	Temperature Limiter.....	13
7.3	VsUP Undervoltage Reset .....	13
7.3.1	VsUP Undervoltage in Normal Mode.....	13
7.3.2	VsUP Undervoltage in Standby Mode / Sleep Mode.....	13
7.3.3	VsUP Undervoltage in Low Slew Mode.....	13
7.4	RESET.....	14
7.5	VCC Undervoltage Reset .....	14
7.6	Window Watchdog (WWD).....	14
7.7	LIN Transceiver .....	15
7.8	Operating Modes and States.....	15
7.8.1	Normal Mode .....	15
7.8.2	Standby Mode.....	15
7.8.3	Sleep Mode.....	15
7.8.4	Temporary Shutdown Mode .....	16
7.8.5	Thermal Shutdown State .....	16
7.9	State Diagram.....	17
8	Application Information .....	18
8.1	Initialization.....	18
8.2	Wake-Up.....	19
8.3	Over-Temperature Shutdown .....	19
8.4	LIN BUS Transceiver .....	19
8.4.1	Transmit Mode.....	19
8.4.2	Receive Mode.....	20

8.5 RX and TX Interface .....	20
8.6 MODE Input EN .....	21
8.7 Serial Port Interface .....	23
8.7.1 Device Configuration using 2-Wire Serial Port .....	23
8.8 Control and Diagnosis Registers .....	26
8.8.1 Definition of Control and Status Registers .....	26
9 Package Drawings and Markings .....	28
10 Ordering Information .....	31

## 4 Pin Assignments

Figure 2. Pin Assignments (Top View)

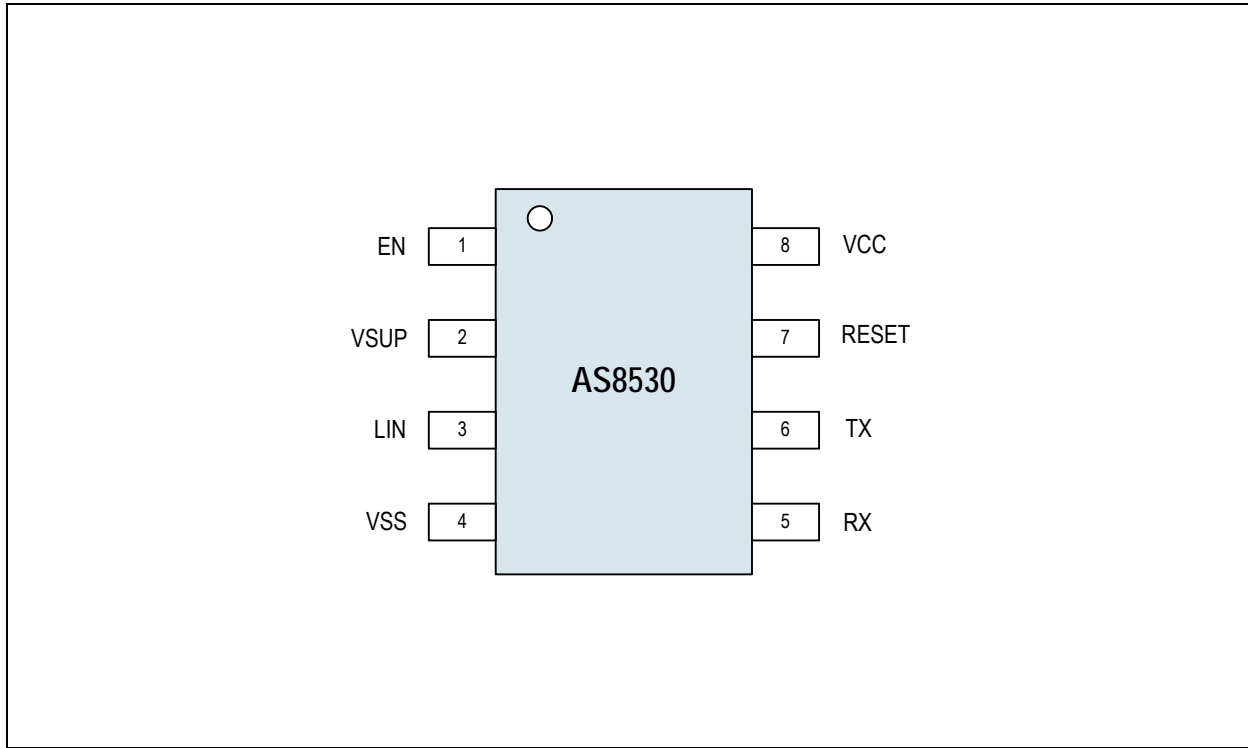

### 4.1 Pin Descriptions

Table 1. Pin Descriptions

Pin Number	Pin Name	Pin Type	Special Requirements	Description
1	EN	Digital input with pull-down	2kV ESD	Enable high-voltage compatible pin with pull down to VSS and ½ VCC trigger level, active high.
2	VSUP	Supply pad	Load dump (42V max), 4kV HBM ESD, Jump start (27V max)	Battery supply
3	LIN	Analog I/O	Conforms to LIN 2.1, 6kV HBM ESD	LIN Bus
4	VSS	Supply pad		
5	RX	Digital output with pull-up	2kV ESD	LIN transceiver receive signal, data out in test mode
6	TX	Digital input with pull-up		LIN transceiver transmit signal, clock in test mode
7	RESET	Digital output		Digital output referenced to VCC, active low
8	VCC	Supply pad		Regulated 5V / 3.3V supply for loads up to 50mA. OTP selectable

## 5 Absolute Maximum Ratings

Stresses beyond those listed in [Table 2](#) may cause permanent damage to the device. These are stress ratings only, and functional operation of the device at these or any other conditions beyond those indicated in [Electrical Characteristics on page 6](#) is not implied. Exposure to absolute maximum rating conditions for extended periods may affect device reliability.

Table 2. Absolute Maximum Ratings

Parameter	Min	Max	Units	Comments	
<b>Electrical Parameters</b>					
DC Supply Voltage	V <sub>SUP</sub>	-0.3	42	V	Transient up to 500ms duration
	EN	-0.3	V <sub>SUP</sub> + 0.3	V	
	V <sub>CC</sub>	-0.3	7	V	
	LIN	-27	+40	V	
	RESET, RX, TX	-0.3	V <sub>CC</sub> + 0.3	V	
Input current (latchup immunity) I <sub>scr</sub>	-100	100	mA	Norm: JEDEC 78	
<b>Electrostatic Discharge</b>					
Electrostatic Discharge (ESD) Norm: AEC-Q-100-002	±2		kV	For on board signals V <sub>CC</sub> , TX, RX, Reset	
	±4			For V <sub>SUP</sub>	
	±6			LIN to V <sub>SS</sub> , HBM Model	
<b>Continuous Power Dissipation</b>					
Total operating power dissipation (all supplies and outputs) P <sub>t</sub>		0.25	W	epSOIC8 in still air, soldered on JEDEC standard board @125° ambient, static operation = no time limit	
<b>Temperature Ranges and Storage Conditions</b>					
Storage temperature (T <sub>strg</sub> )	-55	+150	°C		
Package body temperature (T <sub>body</sub> )		+260	°C	<i>The reflow peak soldering temperature (body temperature) specified is in accordance with IPC/JEDEC J-STD-020 "Moisture/Reflow Sensitivity Classification for Non-Hermetic Solid State Surface Mount Devices".</i> The lead finish for Pb-free leaded packages is matte tin (100% Sn).	
Humidity non-condensing	5	85	%		
Moisture Sensitive Level		3		Represents a maximum floor life time of 168h	

## 6 Electrical Characteristics

### 6.1 Operating Conditions

Symbol	Parameter	Conditions	Min	Typ	Max	Units
VSUP	Positive Supply Voltage	Normal operating condition	6		18	V
VSS	Negative Supply Voltage		0			V
TAMB	Ambient temperature	Maximum junction temperature (T <sub>J</sub> ) 150°C	-40		+125	°C
I <sub>supp</sub>	Supply Current				65	mA

### 6.2 Digital Inputs and Outputs

All pull-up, pull-downs have been implemented with active devices. RESET and RX have been measured with 100pF load.

Symbol	Parameter	Conditions	Min	Typ	Max	Units
<b>EN Input</b>						
V <sub>IH</sub>	High level input voltage	High Voltage Pin which can also be connected to VSUP	0.8V <sub>CC</sub>			V
V <sub>IL</sub>	Low level input voltage				0.2V <sub>CC</sub>	V
I <sub>LEAK</sub>	Input leakage current	EN = L	-1		+1	μA
I <sub>pd_en</sub>	Pull down current	EN = V <sub>CC</sub>	20		40	μA
<b>TX</b>						
V <sub>IH</sub>	High level input voltage		0.8V <sub>CC</sub>			V
V <sub>IL</sub>	Low level input voltage				0.2V <sub>CC</sub>	V
I <sub>LEAK</sub>	Input leakage current	TX = V <sub>CC</sub>	-1		+1	μA
I <sub>pu</sub>	Pull up current	TX pulled to VSS	-30		-10	μA
<b>RESET</b>						
V <sub>OH</sub>	High level output voltage	I <sub>OUT</sub> = 1 mA, V <sub>SUP</sub> ≥ 6V	V <sub>CC</sub> - 0.5			V
V <sub>OL</sub>	Low level output voltage	V <sub>SUP</sub> ≥ 6V			V <sub>SS</sub> + 0.4	V
<b>RX</b>						
V <sub>OH</sub>	High level output voltage		V <sub>CC</sub> - 0.5			V
V <sub>OL</sub>	Low level output voltage	I <sub>OUT</sub> = 1 mA, V <sub>SUP</sub> ≥ 6V			V <sub>SS</sub> + 0.4	V

## 6.3 Detailed System and Block Specifications

### 6.3.1 Electrical System Specifications

Symbol	Parameter		Conditions	Min	Typ	Max	Units
IDD <sub>nom</sub> <sup>1</sup>	Current consumption	Normal mode	No load on VCC, LIN recessive, VSUP= 12V		300		μA
			No load on VCC, LIN dominant, VSUP = 12V		700		μA
		Stand-by mode	Up to 125°C ambient (no load), VSUP= 12V		45		μA
		Sleep mode	Up to 125°C ambient (no load), VSUP=12V		35		μA

1. No external load on the LIN bus

## 6.4 Low Dropout Regulator

The LDO block is a linear voltage regulator, which provides a regulated (band-gap stabilized) output voltage (VCC) from the battery supply voltage (VSUP).

(6V < VSUP < 18V for option 1, 6V < VSUP < 18V option2; -40°C < T<sub>J</sub> < 150°C; all voltages are with respect to ground (VSS); positive current flows into the pin), normal operating mode if not otherwise mentioned.

Symbol	Parameter	Conditions	Min	Typ	Max	Units	
VCC	Regulated supply voltage I <sub>LOAD</sub> 0mA to 50mA	Option 1	4.75		5.25	V	
		Option 2	3.135		3.465		
T <sub>J</sub>	Junction Temperature		-40		150	°C	
VSUP	Supply Voltage Range		6	12	18	V	
VCC	Output Voltage Range	Option 1	Load < 50mA	4.75	5.0	5.25	V
			50mA to 65mA	4.5		5.5	
			Standby mode @ ICC < 5mA	4.5		5.5	
			Load-dump condition, I <sub>LOAD</sub> < 50mA			5.5	
		Option 2	Load < 50mA	3.135	3.3	3.465	
			50mA to 65mA	2.97	3.3	3.63	
			Standby mode @ ICC < 5mA	2.97		3.63	
			Load-dump condition, I <sub>LOAD</sub> < 50mA			3.63	
ICC_SH	Output Short Circuit Current	Normal mode	50		250	mA	
		Standby mode	5		250		
dVCC1	Line Regulation	$\Delta V_{CC} / \Delta V_{SUP}$			8	mV/V	
LOREG_SM	Load Regulation (Standby mode)	$\Delta V_{CC} / \Delta I_{CCn}$ (for I <sub>LOAD</sub> > 500μA)			10	mV/mA	
LOREG_NM	Load Regulation (Normal mode)	$\Delta V_{CC} / \Delta I_{CCn}$ (for I <sub>LOAD</sub> > 500μA)			1	mV/mA	
CL1	Output Capacitor (Electrolytic)		2.2		10	μF	
ESR1			1		10	Ω	
CL2	Output Capacitor (Ceramic)		100		220	nF	
ESR2			0.02		1	Ω	
CSUP1E	Input capacitor (Electrolytic)		10		100	μF	
ESR1_CSUP			1		10	Ω	
CSUP2C	Input capacitor (Ceramic)	For EMC suppression	100		220	nF	
ESR2_CSUP			0.02		1	Ω	

## 6.5 LIN Transceiver

### 6.5.1 DC Electrical Characteristics

( $4.5V < V_{CC} < 5.5V$ ;  $6V < V_{SUP} < 18V$ ;  $-40^{\circ}C < T_J < 150^{\circ}C$ ,  $V_{BUS}$  is the voltage on the LIN node. All voltages are with respect to ground ( $V_{SS}$ ); positive current flows into the pin.

Symbol	Parameter	Conditions	Min	Typ	Max	Units
<b>Driver</b>						
$I_{bus\_lim}$		Current limitation in Dominant State <sup>1</sup> LIN = $V_{SUP\_max}$	40	120	200	mA
LIN_VOL		Output Voltage BUS (dominant state), $I_{LIN} = 40mA$ (short-circuit condition tested at $V_{OL} = 2.5V$ )			2	V
	Pull-up resistor	Normal mode (recessive BUS level on TX pin)	20	40	60	k $\Omega$
$I_{bus\_leak\_rec}$		Driver OFF; $V_{SUP} = 7.0V, 8V < V_{BUS} < 18$			20	$\mu A$
<b>Receiver</b>						
$I_{bus\_leak\_dom}$	Input Leakage current at receiver	Input Leakage current at receiver Driver OFF; $V_{bus} = 0V$ ; $V_{SUP} = 12V$ ; $V_{CC} = 5V$	-1			mA
$I_{bus\_no\_GND}$		$V_{SS} = V_{SUP}$ ; $V_{SUP} = 12V$ ; $0V < V_{BUS} < 18V, V_{CC} = 5V$ <sup>2</sup>	-1		1	mA
$I_{bus\_no\_bat}$		$V_{SUP} = V_{SS}$ ; $0V < V_{BUS} < 18V, V_{CC} = V_{SS}$ <sup>2</sup>			100	$\mu A$
$V_{bus\_dom}$					0.4	$V_{SUP}$
$V_{bus\_rec}$			0.6			$V_{SUP}$
$V_{bus\_cnt}$		$V_{bus\_cnt} = (V_{th\_dom} + V_{th\_rec})/2$ <sup>3</sup>	0.475		0.525	$V_{SUP}$
$V_{hys}$		$V_{hys} = (V_{th\_dom} - V_{th\_rec})$ <sup>3</sup>	0.05		0.175	$V_{SUP}$

1. This failure condition triggers thermal shut down when shut down temperature threshold is exceeded.

2. Not production tested.

3.  $V_{th\_dom}$ : Receiver threshold of the recessive to dominant LIN bus edge  
 $V_{th\_rec}$  : Receiver threshold of the dominant to recessive LIN bus edge

## 6.5.2 AC Electrical Characteristics

LIN Driver, Bus load conditions ( $C_{BUS}$ ;  $R_{BUS}$ ): 1nF; 1k $\Omega$  / 6,8nF; 660 $\Omega$  / 10nF; 500 $\Omega$

Symbol	Conditions	Min	Typ	Max	Units
D1 (worst case 20Kbps transmission)	$V_{th\_rec(max)} = 0.744 \times VSUP$ ; $V_{th\_dom(max)} = 0.581 \times VSUP$ ; $VSUP = 6.0V$ to 18V; tbit = 50 $\mu$ s; $D1 = t_{bus\_rec(min)} / (2 \times tbit)$	0.369			
D2 (worst case 20kbps transmission)	$V_{th\_rec(min)} = 0.422 \times VSUP$ ; $V_{th\_dom(min)} = 0.284 \times VSUP$ ; $VSUP = 6V$ to 18V; tbit = 50 $\mu$ s; $D2 = t_{bus\_rec(max)} / (2 \times tbit)$			0.581	
D3 (worst case 10.4kbps transmission)	$V_{th\_rec(max)} = 0.778 \times VSUP$ ; $V_{th\_dom(max)} = 0.616 \times VSUP$ ; $VSUP = 6.0V$ to 18V; tbit = 96 $\mu$ s; $D3 = t_{bus\_rec(min)} / (2 \times tbit)$	0.417			
D4 (worst case 10.4kbps transmission)	$V_{th\_rec(min)} = 0.389 \times VSUP$ ; $V_{th\_dom(min)} = 0.251 \times VSUP$ ; $VSUP = 6V$ to 18V; tbit = 96 $\mu$ s; $D4 = t_{bus\_rec(max)} / (2 \times tbit)$			0.59	
$t_{dLR}$	$V_{CC} = 5V$ ; Propagation delay bus dominant to RX LOW			6	$\mu$ s
$t_{dHR}$	$V_{CC} = 5V$ ; Propagation delay bus dominant to RX HIGH			6	$\mu$ s
$t_{RS}$	Receiver Delay symmetry	-2		2	$\mu$ s
$t_{wake}$	Wake-up delay time	30		150	$\mu$ s
$t_{sln}$	Transition from standby mode to normal mode (clock frequency is 128kHz $\pm$ 25%)		4		Clock cycles
$t_{nsl}$	Transition from normal mode to standby mode (clock frequency is 128kHz $\pm$ 25%)		6		Clock cycles
$t_{rec\_deb}$	Receiver De-bounce time	1		3	$\mu$ s
$C_{int}$	Guaranteed by design		220	250	pF

**Note:** Sleep-mode to Normal mode transition is identical to the Power-ON sequence after the remote wakeup event on LIN bus. The transition time will include the  $t_{RES}$  (RESET time) and start-up time for the LDO.

Figure 3. LIN Timing

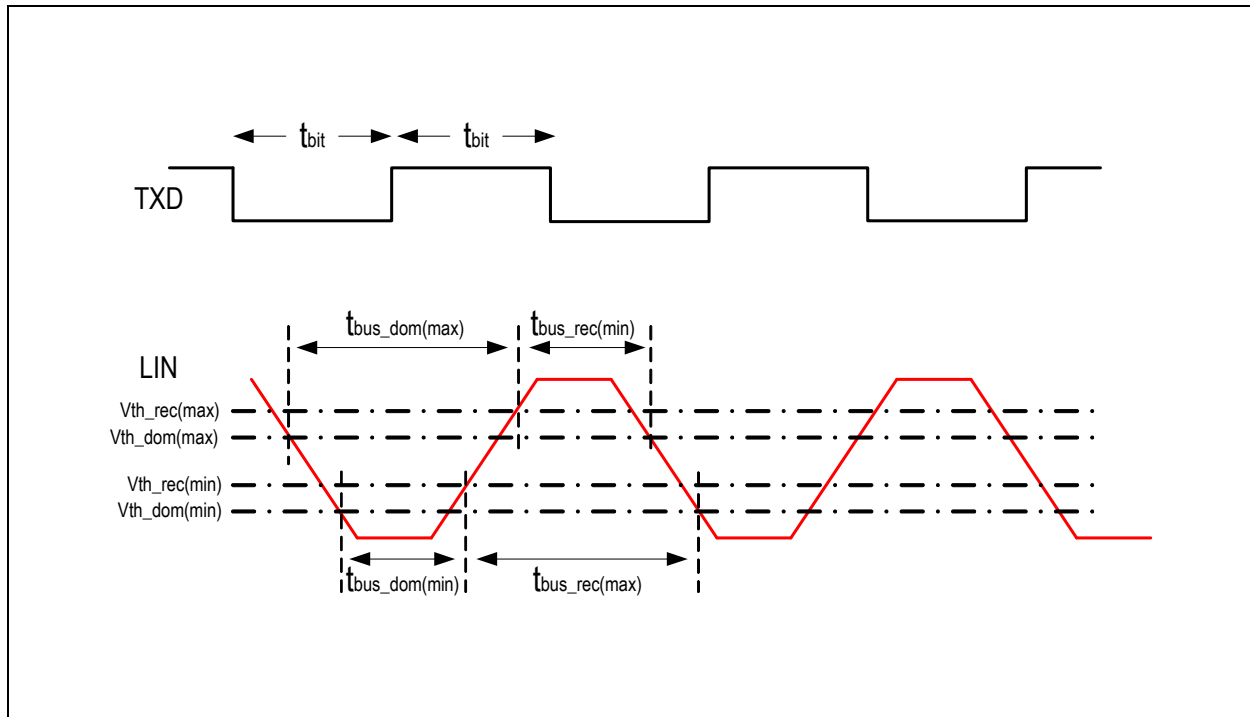

### 6.5.3 Temperature Limiter

Symbol	Parameter	Conditions	Min	Typ	Max	Units
$T_{sd}$	Shut down temperature	Junction temperature	139		171	°C
$T_{ret}$	Return temperature	During shut down, the sensor must be powered by VSUP. Thermal shut down disables LDO and sets all drivers to high impedance, the IC returns from shut down with POR.	121		149	°C
$T_{otset}$	Over-temp warning flag set	The temperature beyond which the warning flag is set.	121		149	°C
$T_{otclear}$	Over-temp warning flag clear	The return temperature when the warning flag is cleared	103		127	°C

### 6.5.4 TX Timeout Watchdog

Symbol	Parameter	Conditions	Min	Typ	Max	Units
$t_{in\_wdog}$	Time out duration (dominant state)		0.5	1	2	s

## 6.6 V<sub>CC</sub> Undervoltage Reset and Window Watchdog

The values in this table are valid for normal and standby modes. All parameters are tested, unless mentioned otherwise.

Symbol	Parameter	Conditions	Min	Typ	Max	Units
V <sub>uvr_off</sub>	VCC under-voltage threshold off (Default)	Rising edge of VCC	2.55		2.95	V
V <sub>uvr_on</sub>	VCC under voltage threshold on (Default)	Falling edge of VCC	2.3		2.7	V
V <sub>uvr1_off</sub>	VCC under voltage threshold off (Factory Option)	Rising edge of VCC <sup>1</sup>	3.0		3.4	V
V <sub>uvr1_on</sub>	VCC under voltage threshold on (Factory Option)	Falling edge of VCC <sup>1</sup>	2.75		3.15	V
V <sub>uvr2_off</sub>	VCC under voltage threshold off (Factory Option)	Rising edge of VCC <sup>1</sup>	3.5		3.9	V
V <sub>uvr2_on</sub>	VCC under voltage threshold on (Factory Option)	Falling edge of VCC <sup>1</sup>	3.25		3.65	V
V <sub>uvr3_off</sub>	VCC under-voltage threshold off (Factory Option)	Rising edge of VCC <sup>1</sup>	4.0		4.4	V
V <sub>uvr3_on</sub>	VCC under voltage threshold on (Factory Option)	Falling edge of VCC <sup>1</sup>	3.75		4.15	V
V <sub>hyst_vcc</sub>	Hysteresis of under-voltage threshold on/off VCC	Default and all other factory options	0.1	0.25	0.4	V
t <sub>fr</sub>	Spike filter on VCC	To remove disturbance	4			μs
V <sub>svvr_off</sub>	VSUP under-voltage threshold off			3.85		V
V <sub>svvr_on</sub>	VSUP under-voltage threshold on	BOR level (considered to be the Master Reset for AS8530)		3.25		V
WD_TCL	WWD non-service time (if factory enabled)	RESET will be generated <sup>1 2</sup>	0-75	0-100	0-125	ms
WD_TSV	WWD Service – time (if factory enabled)	RESET will not be generated <sup>1</sup>	75-150	100-200	125-250	ms
t <sub>Res</sub>	Reset delay time	4ms, 16ms, 32ms (typ) are factory options (min = -25% and max = +50% of typical)	6	8	12	ms
T <sub>shd</sub>	Temporary shutdown reset active time		0.1		1	s

1. These are factory options which could be made available on specific request.
2. -40%, -20%, +20%, +60%, and +100% timings are available as factory options.

## 6.7 Two Port Serial Interface

Symbol	Parameter	Conditions	Min	Typ	Max	Units
<b>General</b>						
BR <sub>2WIRE_SPI</sub>	Bit rate				250	Kbps
T <sub>ENCLK_H</sub>	Clock high time		2			μs
T <sub>ENCLK_L</sub>	Clock low time		2			μs
<b>Write timing</b>						
t <sub>DI_SU</sub>	Data in setup time		20			ns
t <sub>DI_HD</sub>	Data in hold time		10			ns
<b>Read timing</b>						
t <sub>DO_S</sub>	Data out setup time		130			ns
t <sub>DO_HD</sub>	Data out hold time		135			ns
t <sub>DO_D</sub>	Data out delay				80	ns
t <sub>DI_HZ</sub>	Data in to high impedance delay	Time for the Microcontroller to release the TX bus			80	ns
<b>Timing parameters when entering 2-Wire SP mode</b>						
T <sub>tx_su</sub>	TX setup time before EN goes Low		20			ns
T <sub>tx_hd</sub>	TX hold time after EN goes High		20			ns
T <sub>tx_SP_trigger</sub>	EN falling edge to TX falling edge	To enter into 2-Wire SP mode	2		10	μs
T <sub>STNDY_trigger</sub>	TX high time from EN falling edge	To enter into Sleep/Standby mode	5			cycles
T <sub>en_ENSCLK</sub>	EN falling edge to start of 2-wire serial port clock		5			cycles

## 7 Detailed Description

The AS8530 chip consists of a low drop-out regulator and a LIN bus transceiver, which is a bi-directional bus interface for data transfer between LIN bus and the LIN protocol controller. Additionally integrated is a RESET unit with a power-on-reset delay and a programmable window watchdog. It also includes a watchdog time-out on LIN TX node to indicate if the microcontroller is stuck in a loop and to release unintentional LIN bus dominant state.

### 7.1 Voltage Regulator (LDO)

The voltage regulator has three operating modes. The features of the operating modes are given below:

- **Normal mode:** Stability to be better  $\pm 0.25V$  over input range and temperature for load current up to 50mA. The LDO Output provides a voltage of 5V or 3.3V as OTP option.
- **Standby mode:** The Standby mode is a low quiescent current mode used in car applications that are always switched on. The load current in standby mode is 5mA. Quiescent current (no load) is less than 45mA typically at room temperature.
- **Sleep mode:** Power down or temporary shutdown of the regulator can be set by a register bit. This bit can be written through 2-wire MCU interface.

The LDO takes the input from bandgap and scales it up to the required voltage. The LDO starts charging only after the POR- $V_{SUP}$  event occurs (RESET\_ $V_{SUP\_N}$  switched from low to high). The LDO can be powered-down by a control signal (temporary shutdown register) for the temporary shutdown mode.

### 7.2 Temperature Limiter

Temperature limiter produces a power down when temperature exceeds  $155^{\circ}C \pm 10\%$ . It powers up and generates a reset when it returns to  $135^{\circ}C \pm 10\%$  junction temperature. During thermal shut down, temperature sensor is supplied by  $V_{SUP}$ . During the temperature ramp-up phase, as soon as the temperature exceeds  $135^{\circ}C \pm 10\%$ , a warning signal is issued and is written into the diagnostic register, which can be read through the SP interface.

### 7.3 $V_{SUP}$ Undervoltage Reset

$V_{SUP}$  undervoltage reset generates a reset RESET\_ $V_{SUP\_N}$ , switched from low to high when  $V_{SUP}$  ramps up above VSUVR\_OFF. This is used to enable proper initialization of mode control and diagnostic registers. If  $V_{SUP} < VSUVR\_ON$ , then RESET\_ $V_{SUP\_N}$  switches from high level to low level (active). This is considered to be the master reset and will have the highest priority over all other signals. As soon as  $V_{SUP} < VSUVR\_ON$ , the LDO, LIN Transceiver is completely shut off and system comes to a complete stop. AS8530 enters into the normal operating mode only after  $V_{SUP} > VSUVR\_OFF$ .

#### 7.3.1 $V_{SUP}$ Undervoltage in Normal Mode

Supply Voltages below VSUVR\_OFF and above VSUVR\_ON do not influence the voltage regulator. The output voltage  $V_{CC}$  follows  $V_{SUP}$ .

#### 7.3.2 $V_{SUP}$ Undervoltage in Standby Mode / Sleep Mode

No exit from the sleep mode or standby mode take place if the  $V_{SUP}$  voltage drops down to VSUVR\_OFF. If  $V_{SUP}$  goes below VSUVR\_ON, RESET\_ $V_{SUP\_N}$  is active and resets the mode control and diagnostic register. The voltage regulator, LIN Transceiver modules are turned off. If  $V_{SUP}$  rises again above VSUVR\_OFF, RESET\_ $V_{SUP\_N}$  is switched from low to high. The system enters normal mode where LIN Transceiver and LDO are switched on.

#### 7.3.3 $V_{SUP}$ Undervoltage in Low Slew Mode

The behavior of AS8530 at low  $V_{SUP}$  voltages is equal to the sleep mode. The low slew mode (set by control register through serial interface as an option) will be cancelled, if  $V_{SUP}$  drops below VSUVR\_ON in this mode. The AS8530 enters the normal mode, if  $V_{SUP}$  rises again above VSUVR\_OFF.

## 7.4 RESET

Reset generates an external RESET signal to reset the microcontroller and all other external circuits. The reset functionality is illustrated in Figure 4. Reset consists of a digital buffer at the output. RESET signal can be affected by RESET\_VCC\_N (which is the under-voltage reset on VCC) and Window watchdog output. All those conditions which cause a drop in the VCC voltage will be detected from the low voltage reset unit, which in-turn generates a reset signal. States like Temporary shut-down, Over-temperature monitor will influence the RESET output through RESET\_VCC\_N signal only.

Figure 4. Reset Functionality

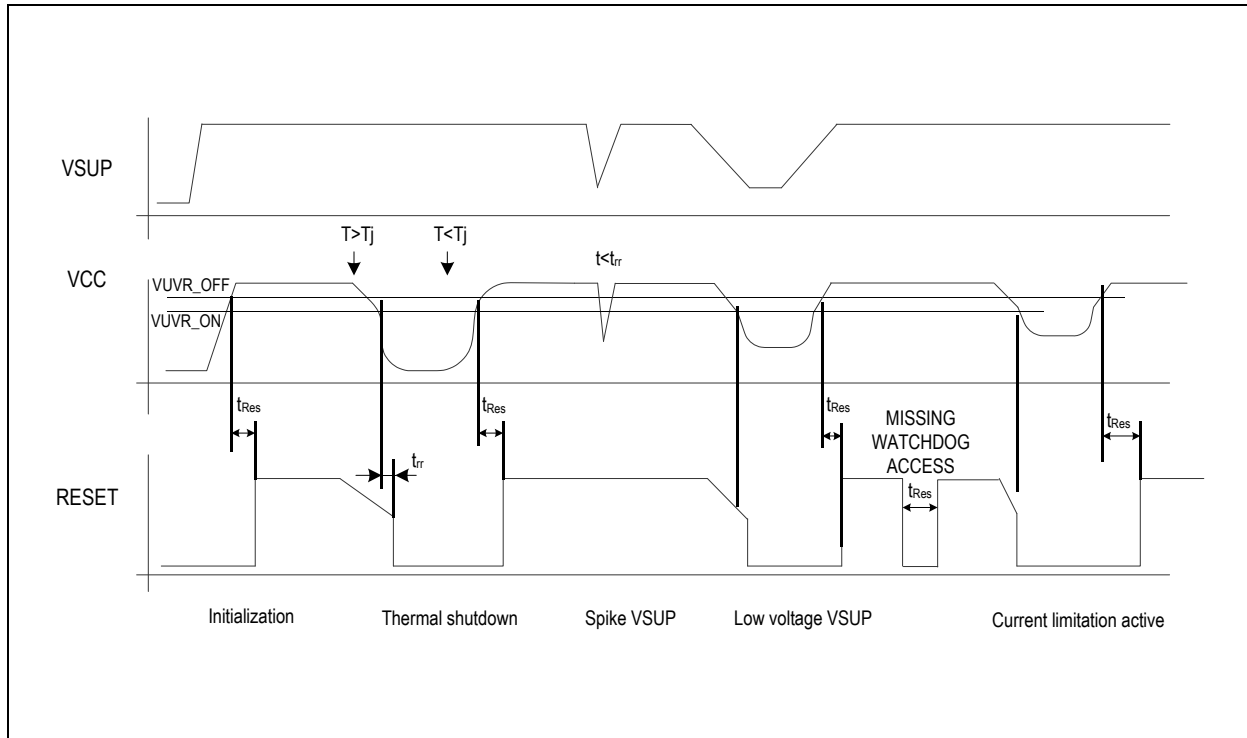

## 7.5 V<sub>CC</sub> Undervoltage Reset

The POR-VCC generates RESET\_VCC\_N signal as output which determines under-voltage reset of the output of the LDO. The rising edge of the VCC gives an under-voltage reset "off" and the falling edge of the VCC gives an under-voltage reset "on". This under-voltage signal is used to control the RESET output. When VCC rises up  $V_{uvr\_off}$  for a period greater than reset duration ( $t_{Res}$ ) then RESET\_VCC\_N switches from low level to high level and pin RESET is inactive (high). If VCC falls below  $V_{uvr\_on}$  for a period greater than a predetermined delay ( $t_{tr}$ ) then RESET\_VCC\_N switches from high level to low level and pin RESET is active (low). The RESET\_VCC\_N signal is used to initialize Window watchdog timer, TX time-out, Test control circuits, 2-wire SP, and logic associated with SP (everything other than the SP control registers). VCC under-voltage reset threshold voltage level adjustment can be made by 2 bit OTP as explained in OTP interface.

## 7.6 Window Watchdog (WWD)

To keep the external microcontroller always in proper function state, a window watchdog circuit is implemented. The WWD trigger is generated by external MCU through SP interface. If the window is missed, a reset on the RESET pin with certain reset time ( $t_{Res}$ ) is generated. The WWD function can be enabled or disabled by factory setting. The watchdog is started after the ASSP exits reset. Under normal working conditions, microcontroller gives a WWD trigger every time in the window period of WD\_TSV (service time). If the trigger does not occur during WD\_TSV or occurs too early during WD\_TCL (non-service time), then RESET output is pulled low (active), which will reset the micro-controller. WWD circuit is turned on after the RESET pin goes back to high (inactive). If  $V_{CC} < V_{uvr\_on}$ , WWD circuit is switched off. When the WWD function is enabled, there is a 3-bit factory programming available to set the trigger window.

Figure 5. Window Watchdog Trigger

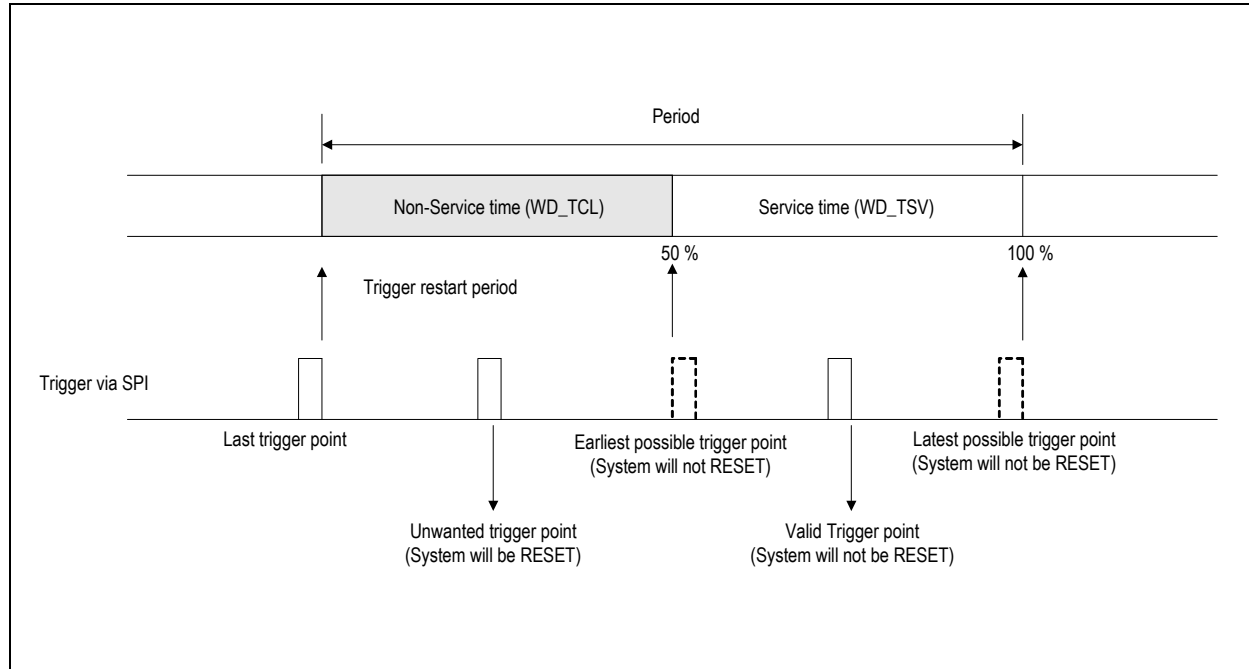

## 7.7 LIN Transceiver

The transceiver provides short circuit limitation, hardware watchdog and over temperature shut down features. The TX watchdog timer is active when TX is pulled low (active). As soon as the TX watchdog timeout occurs, the LIN bus is released from dominant state to recessive state. The LIN transceiver has a pull-up resistor (for the slave node; extra resistor externally for the master node) to the VSUP. A diode protection is available to protect it from back supply from bus line.

The LIN transmitter has the basic functionality of relaying the data from the micro-controller on to the LIN. The data on the LIN needs to have controlled slew to have reduced EMI. The receiver relays the data from the LIN to the micro-controller. This transmitter has optimized EMC performance across different loading conditions conforming to the LIN 2.1 standards. The wake-up detects a wake up event on the LIN.

## 7.8 Operating Modes and States

The AS8530 provides four main operating modes "normal", "sleep/stand-by" (programmed by OTP), "temporary shutdown" and "thermal shutdown". The LIN transceiver can be programmed to operate with lower slew in the normal mode. Refer to [Table 3](#) for a detailed description on transition for each mode.

### 7.8.1 Normal Mode

This is the mode after the power-up. In normal mode, LDO, LIN Transceiver, Window Watchdog, Resistive divider and the line drivers are all turned on. All the blocks are completely functional. LDO is now capable of delivering maximum load current possible as per the device specifications. The LIN Transceiver is capable of sending the TX data from microcontroller to the LIN bus at a maximum rate of 20Kbps. EN signal is set to high and LIN, TX, RX pins can be driven into dominant (low) or recessive (high) states. If the junction temperature increases more than  $T_{otset}$ , a warning flag is set in the diagnostic register, which can be read through the 2-wire interface.

### 7.8.2 Standby Mode

Standby mode is a functional low-power mode where LIN Transceiver is disabled. The LIN wake-up circuit and over-temperature monitor circuit is enabled. Window watchdog, TX timeout watchdog, Resistive divider, relay driver circuits are disabled. EN pin held low in this mode. TX pin is in recessive state (high). CS is pulled to VCC while SDI and SCLK outputs are pulled to VSS.

### 7.8.3 Sleep Mode

As a factory programming option on request the AS8530 offers as a replacement to the standby mode with sleep mode. Sleep mode is the most current saving mode. If EN is held low, the LDO, LIN Transceiver and the reset and window watchdog unit will be switched off. VCC is pulled down to zero. The LIN wake-up circuit, oscillator and over-temperature monitor circuit is active. LIN bus is in recessive state (high). Only wake-up possible is through remote wake-up, through LIN pin, pulling it to dominant state for 100µs typical (low), can change the state of the system.

### 7.8.4 Temporary Shutdown Mode

In this mode, the VCC is pulled down and the LDO is powered down. This mode is introduced to interface with other components which do not have a pin for the reset functionality. This provides an alternative way to reset those components interfacing with AS8530. This mode is default disabled but can be enabled by an OTP option. In this mode, all internal modules supplied by the LDO are disabled. Only the oscillator, control registers are enabled. The VCC output can be temporarily switched off and pulled to VSS. EN signal, RX, TX is pulled low and LIN Transceiver along with the LIN wake-up circuit is powered down. No remote wake-up functionality is possible. LIN bus enters into recessive state. The system goes out of this mode to normal mode after the time-out of an internal counter delay ( $T_{shd}$ ). Normal mode to temporary shutdown transition will be controller by register bit in configuration register.

### 7.8.5 Thermal Shutdown State

If the junction temperature  $T_J$  is higher than  $T_{sd}$ , the AS8530 will be switched into the thermal shutdown mode. The transceiver is completely disabled. No wake-up functionality is available. Window watchdog, TX timeout watchdog, and LDO are completely turned off. Only the over-temperature monitor would be working. As soon as the temperature returns back to  $T_{ret}$ , the system enters normal mode. For more information on transition, see Table 3.

Table 3. Transition Table

Transition		Interface				Reg. 0x05 D0	Flags				Comments
From mode	To mode	LIN	RX	TX	EN		rwake	Uvbat	OT	Uvcc	
Normal Mode	Stand-By	X-RS	X-H <sup>2</sup>	H <sup>3</sup>	H-L <sup>3</sup>	L	X	X	inactive	inactive	TX is high for $T_{STNDY\_triggerr}$
	Sleep <sup>1</sup>	X-RS	X-H <sup>2</sup>	H <sup>3</sup>	H-L <sup>3</sup>	L	X	X	inactive	set	TX is high for $T_{STNDY\_triggerr}^1$
	Temporary Shutdown	X-RS	X-H <sup>2</sup>	X	H <sup>3</sup>	H	X	X	inactive	set	The Control Bit is set through the 2-Wire SP interface
	Over-Temperature	X-RS	X-H <sup>2</sup>	X	X	L	X	X	set	set	
Stand-By Mode	Normal (LW)	X	H-X <sup>2</sup>	X	L-H <sup>3</sup>	L	X	X	inactive	inactive	
	Normal (RW)	X	H-X <sup>2</sup>	H	X	L	set	X	inactive	inactive	Remote Wake up Event occurred on LIN
	Temporary Shutdown	RS	H <sup>2</sup>	H	L	H <sup>3</sup>	X	X	inactive	set	The Control Bit is set through the 2-Wire SP interface
	Over-Temperature	RS	H <sup>2</sup>	H	L	L	X	X	set	set	
Temporary Shutdown Mode	Normal	RS-X	H-X <sup>2</sup>	X	X	L	X	X	inactive	clear	Internal 128ms timer expired
Sleep Mode <sup>3</sup>	Normal	RS-X	H-X <sup>2</sup>	X	X	L	set	X	inactive	clear	Remote Wake up Event occurred on LIN
	Over-Temperature	RS	H <sup>2</sup>	X	X	L	X	X	set	hold	Temperature monitor output asserted (covered by scan)
All States	Power Off	X	X	X	X	X	X	L-H <sup>3</sup>	X	X	

1. Chosen by factory programming option
2. Effect of Transition
3. Cause for Transition

**Note:** L = low state, H = high state, OT = Over-temperature Reset, Uvcc = Undervoltage Vcc, Uvbat = Undervoltage VBAT, rwake =remote wake, X = do not care.

### 7.9 State Diagram

The complete functional state machine for AS8530 is illustrated in Figure 6. Some soft-states in the FSM like “TXWD Wait”, “Standby Wait” and other “wait” states have been included for the sake of completeness.

Figure 6. Finite State Machine Model for the AS8530 System

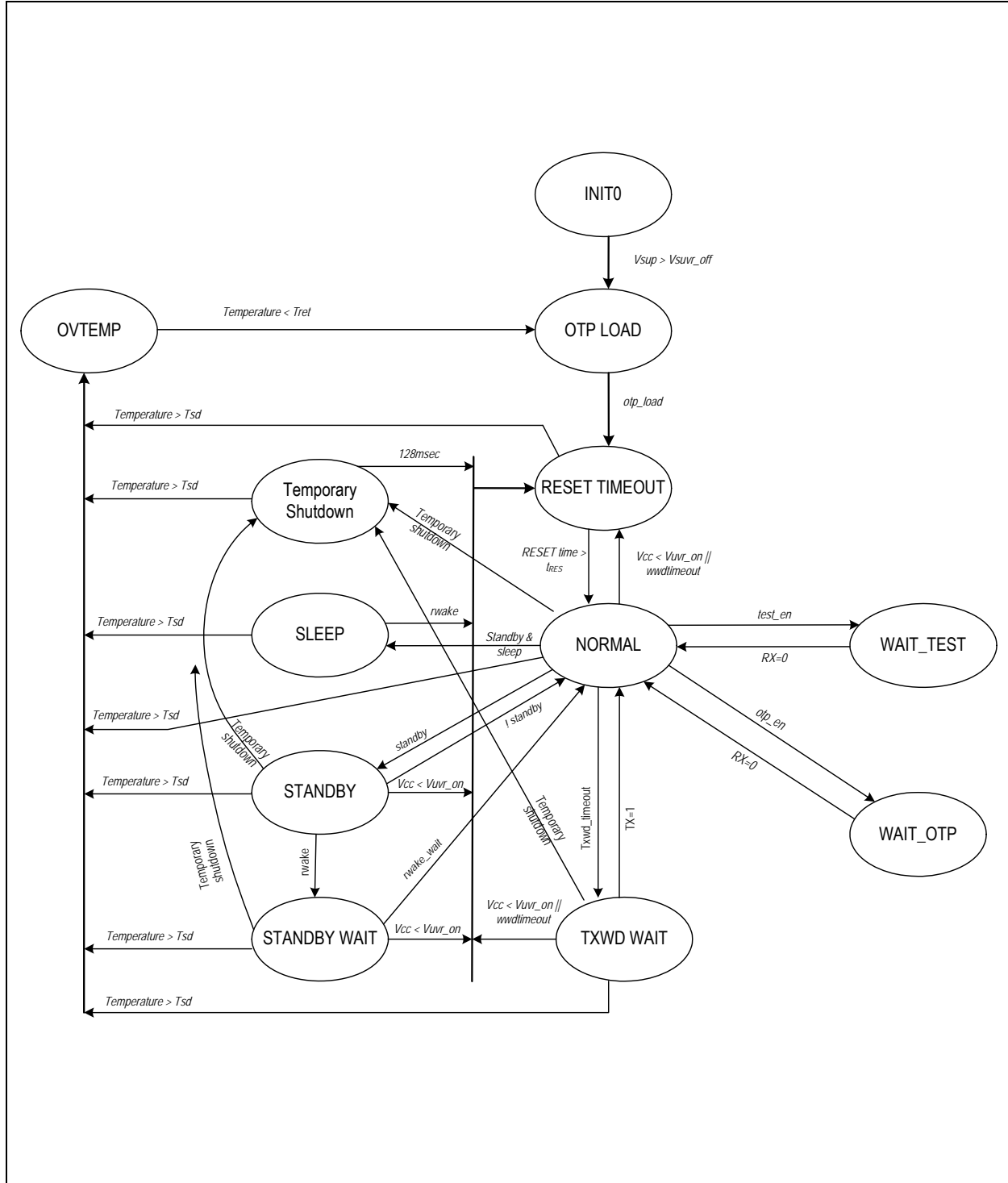

## 8 Application Information

### 8.1 Initialization

When the power supply is switched on, if  $V_{SUP} > V_{SUVR\_OFF}$ ,  $RESET\_VSUP\_N$  becomes inactive (high). After this, the voltage regulator starts with a default LDO output setting of 3.3V and  $V_{VVR\_OFF}$  setting of 2.75V. If  $V_{CC} > V_{VVR\_OFF}$  (2.75V), active-low  $PORN\_2\_OTP$  is generated. The rising edge of  $PORN\_2\_OTP$  loads contents of fuse onto the OTP latch after load access time  $T_{Load}$ .  $LOAD\_OTP\_IN\_PREREG$  signal loads contents of OTP latch onto the pre-regulator domain register. This register gives actual settings of LDO,  $V_{VVR\_OFF}$  and Reset Timeout period  $T_{Res}$ . This is done because the OTP block is powered by the  $V_{CC}$ . If  $V_{CC} > V_{VVR\_OFF}$  (phase 2), Reset timeout is restarted.  $RESET$  signal is de-asserted after Reset Timeout period  $T_{Res}$  (phase 2) and then device enters into normal mode. The circuit initializes correctly also for very slow ramp on  $V_{SUP}$  (of the order of 0.5V/min).

Figure 7. Initialization Sequence for AS8530

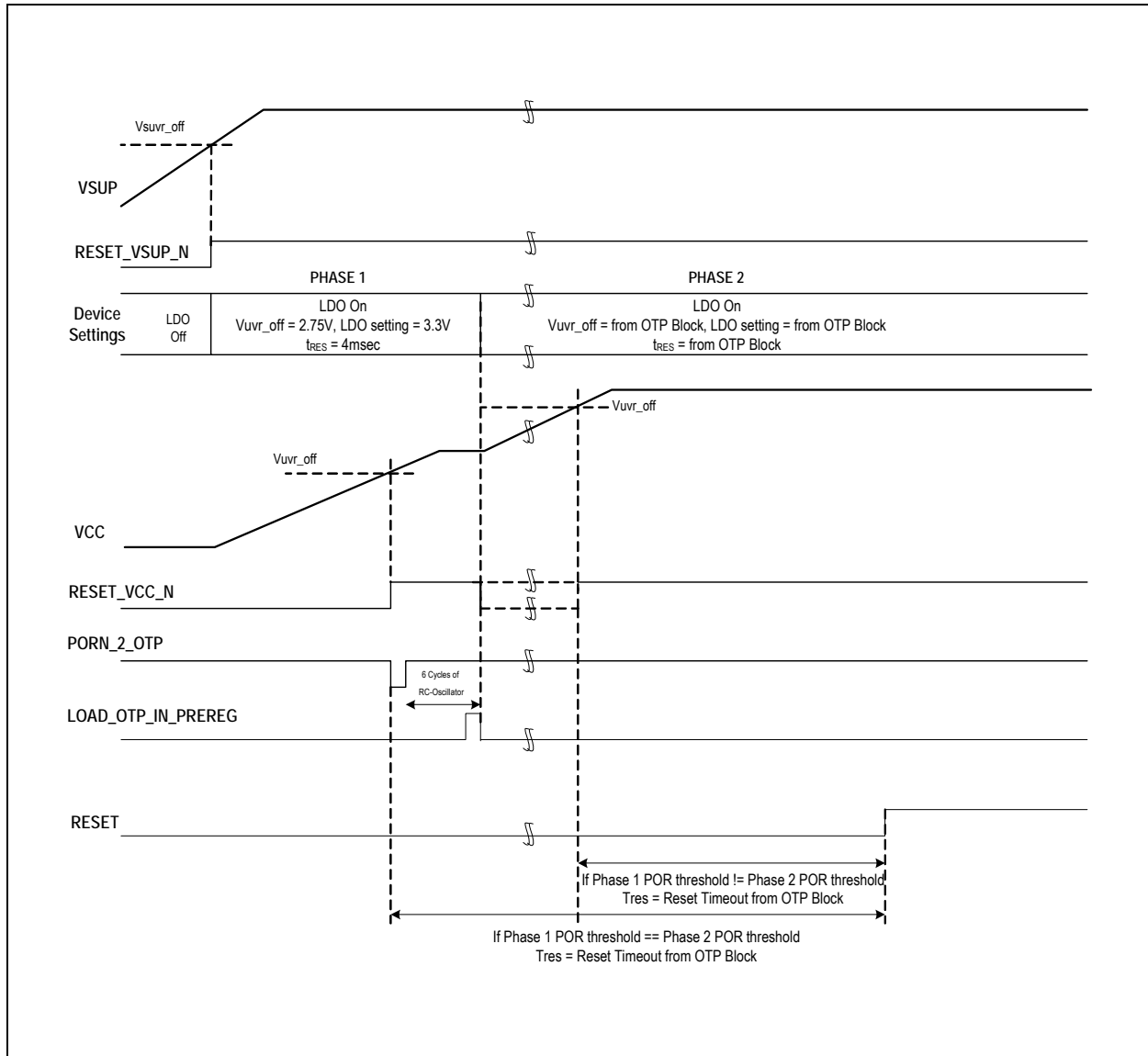

Table 4.  $V_{SUP} > V_{svr\_on}$  and  $V_{CC} < V_{uvr\_on}$ 

Block	Output Signal
TRANSCEIVER = Enabled (disabled only during initial $V_{SUP}$ ramp-up)	LIN = high-z, RX = follows V
LDO = Enabled (disabled only during initial ramp-up)	VCC = low
RELAY DRIVER = Enabled	LDRIVE1 = high, LDRIVE2 = high
RESET = Enabled	RESET = high-z
RESISTIVE DIVIDER = Enabled	VBAT = high, VBAT_DIV = enabled

Table 5.  $V_{SUP} < V_{svr\_on}$ 

Block	Output Signal
TRANSCEIVER = Disabled	LIN = high-z, RX = high-z
LDO = Disabled	VCC = low
RELAY DRIVER = Disabled	LDRIVE1 = high, LDRIVE2 = high
RESET = Disabled	RESET = high-z
RESISTIVE DIVIDER = Disabled	VBAT = high, VBAT_DIV = low

## 8.2 Wake-Up

If the regulator is put into sleep/standby mode, it can be woken up with the BUS interface. A transition on the BUS (high to low) with a minimum predefined low time ( $t_{wake}$ ) puts the regulator into normal mode.

## 8.3 Over-Temperature Shutdown

If the junction temperature increases beyond  $T_{sd}$  the over-temperature recognition will be activated and the regulator voltage will be switched off. The VCC voltage drops down, the reset state is entered and the bus transceiver is switched off (recessive state). After  $T_J$  falls below  $T_{ret}$ , the AS8530 will be initialized again. This initialization starts independently from the voltage levels on EN and BUS. Within the thermal shutdown mode, the transceiver cannot switch to the normal mode either with local or with remote wake-up. The operation of the AS8530 is possible between  $T_J$  (125°C) and the switch off temperature  $T_{sd}$ , but small parameter differences can appear. After over-temperature switch-off, the IC initializes as explained in [Initialization on page 18](#). The low slew mode for LIN Transceiver has to be selected again on re-initialization, if necessary.

## 8.4 LIN BUS Transceiver

The AS8530 has an integrated bi-directional bus interface device for data transfer between LIN bus and the LIN protocol controller. The transceiver consists of a driver with slew rate control, wave shaping and current limitation and a receiver with high voltage comparator followed by a de-bouncing unit.

### 8.4.1 Transmit Mode

During transmission the data at the pin TX will be transferred to the BUS driver to generate a bus signal. To minimize the electromagnetic emission of the bus line, the BUS driver has an integrated slew rate control and wave shaping unit.

Transmitting will be interrupted in the following cases:

- Sleep mode
- Thermal Shutdown active
- Master Reset ( $V_{SUP} < V_{svr\_on}$ )

The recessive BUS level is generated from the integrated 30k pull up resistor in serial with an active diode. This diode prevents the reverse current of VBUS during differential voltage between  $V_{SUP}$  and BUS ( $VBUS > V_{SUP}$ ). No additional termination resistor is necessary to use the AS8530 in LIN slave nodes. If this IC is used for LIN master nodes it is necessary that the BUS pin is terminated via an external 1k $\Omega$  resistor in series with a diode to VBAT.

### 8.4.2 Receive Mode

The data signals from the BUS pin will be transferred continuously to the pin RX. Short spikes on the bus signal are suppressed by the implemented de-bouncing circuit. Including all tolerances the LIN specific receive threshold values of  $0.4 \cdot V_{SUP}$  and  $0.6 \cdot V_{SUP}$  will be securely observed.

Figure 8. Receive Mode Impulse Diagram

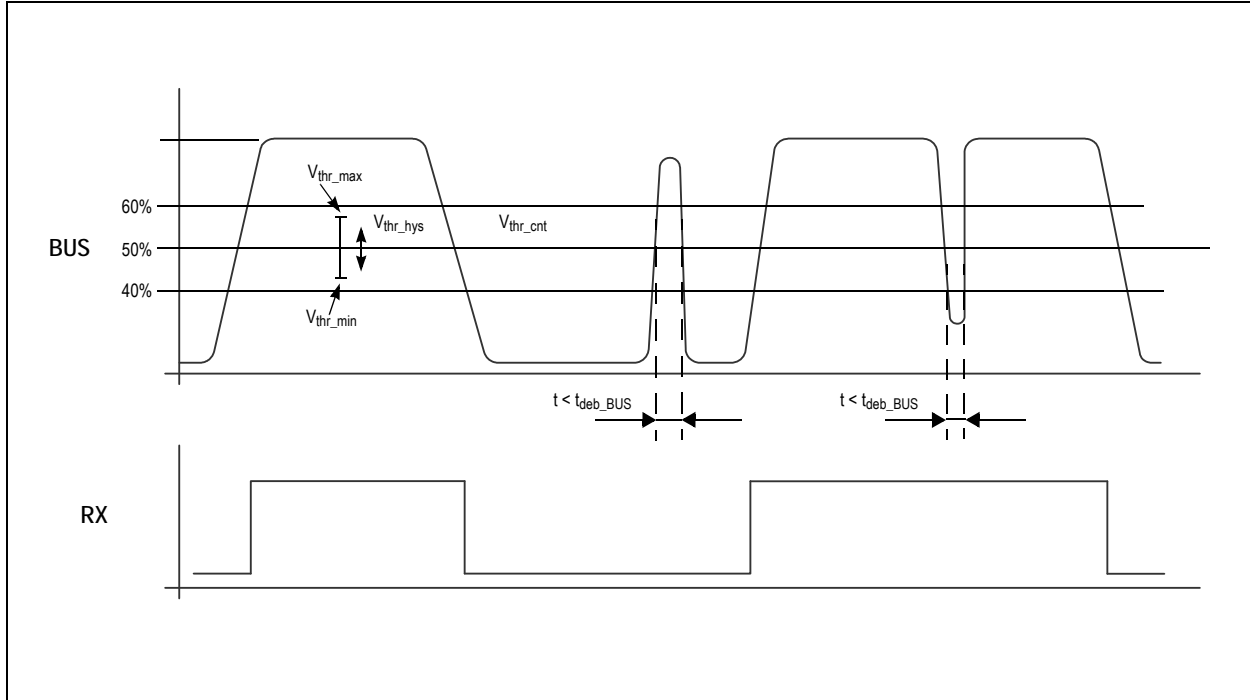

### 8.5 RX and TX Interface

#### Input TX.

The 5V input TX controls directly the BUS level. LIN Transmitter acts like a slew-controlled level shifter. A dominant state (low) on TX leads to the LIN bus being pulled low (dominant state) too. The TX pin has an internal active pull up connected to VCC. This guarantees that an open TX pin generates a recessive BUS level.

Figure 9. TX Input Circuitry

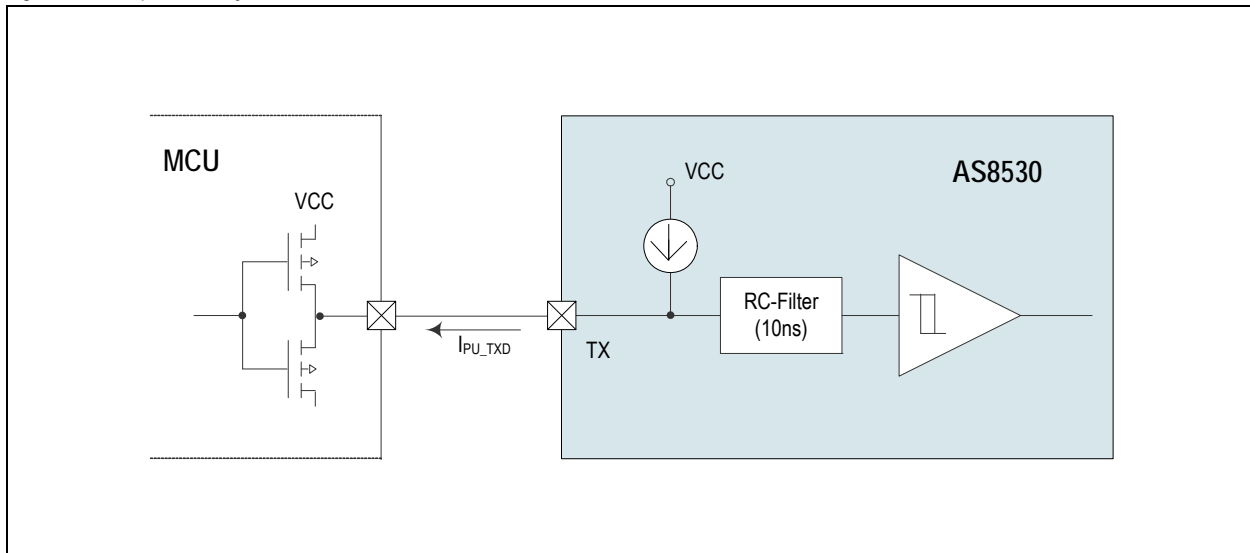

**Output RX.**

The received BUS signal will be output to the RX pin:

$$BUS < V_{thr\_cnt} - 0.5 * V_{thr\_hys} \rightarrow RX = low$$

$$BUS > V_{thr\_cnt} + 0.5 * V_{thr\_hys} \rightarrow RX = high$$

This output is a push-pull driver between VCC and GND with an output current of 1mA.

Figure 10. RX Output Circuitry

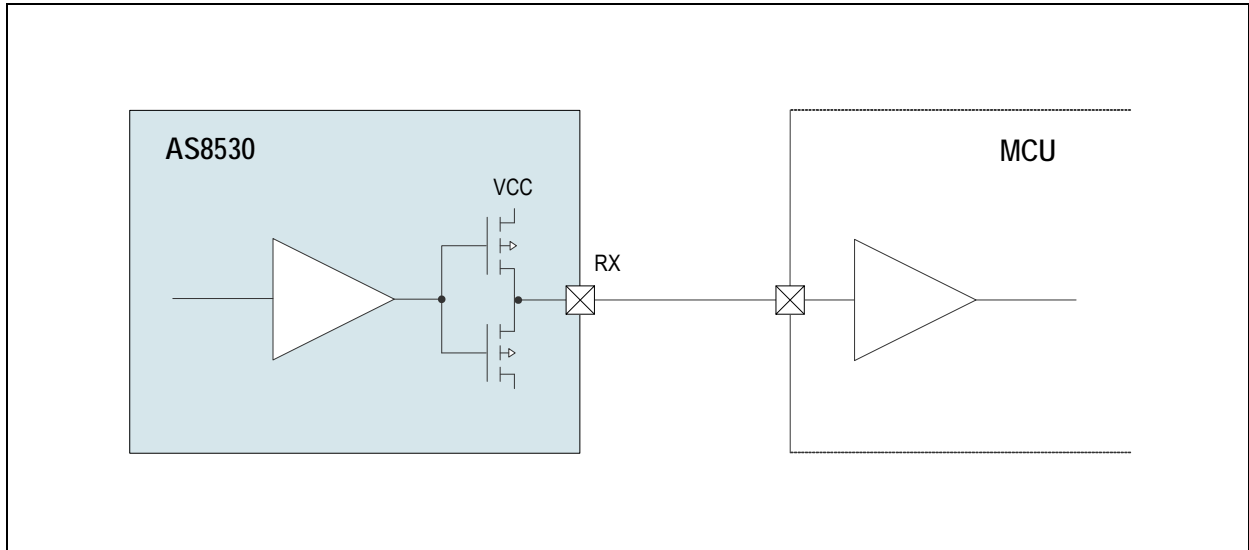

**8.6 MODE Input EN**

The AS8530 is switched from normal mode to the standby/sleep mode with a falling edge on EN and keeping TX high for  $T_{STNDY\_trigger}$  time. Device is switched from standby mode to normal mode with a rising edge at the EN pin. The mode change for AS8530 with a falling edge at EN can be done independently from the state of the bus transceiver. Device enters into Serial port mode by forcing EN low and driving TX high to low within  $T_{tx\_SP\_trigger}$  time after EN forced to low.

This ensures the direct control of device to enter into Standby/Sleep mode by microcontroller using EN pin.

Figure 11. EN Pin Functionality

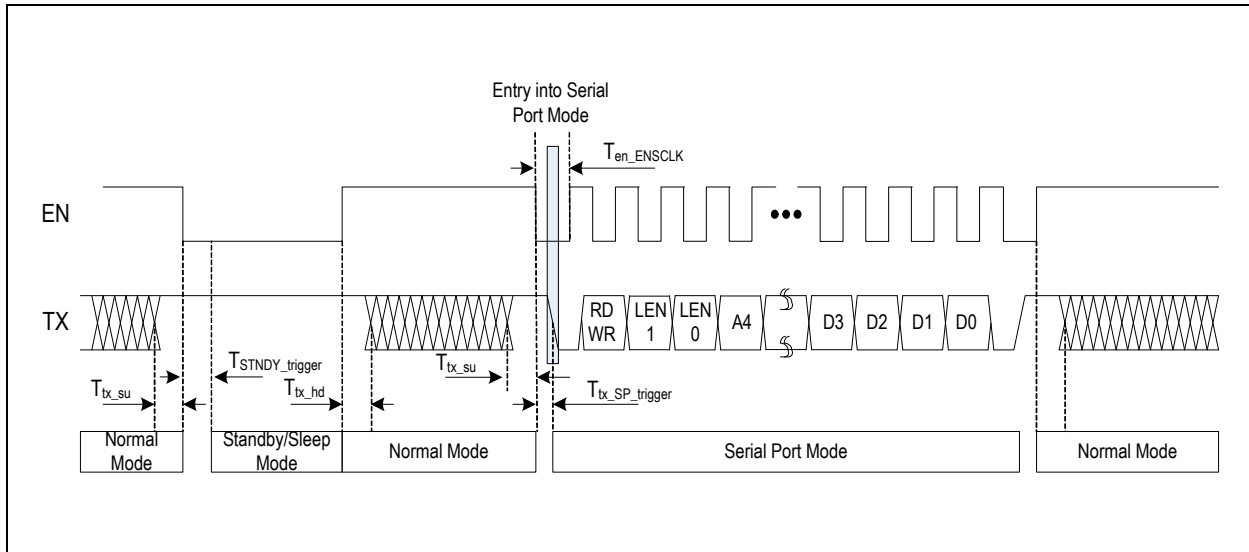

The EN input has an internal active pull down to secure that if this pin is not connected, a low level will be generated.

Figure 12. Enable Controlled via. MCU

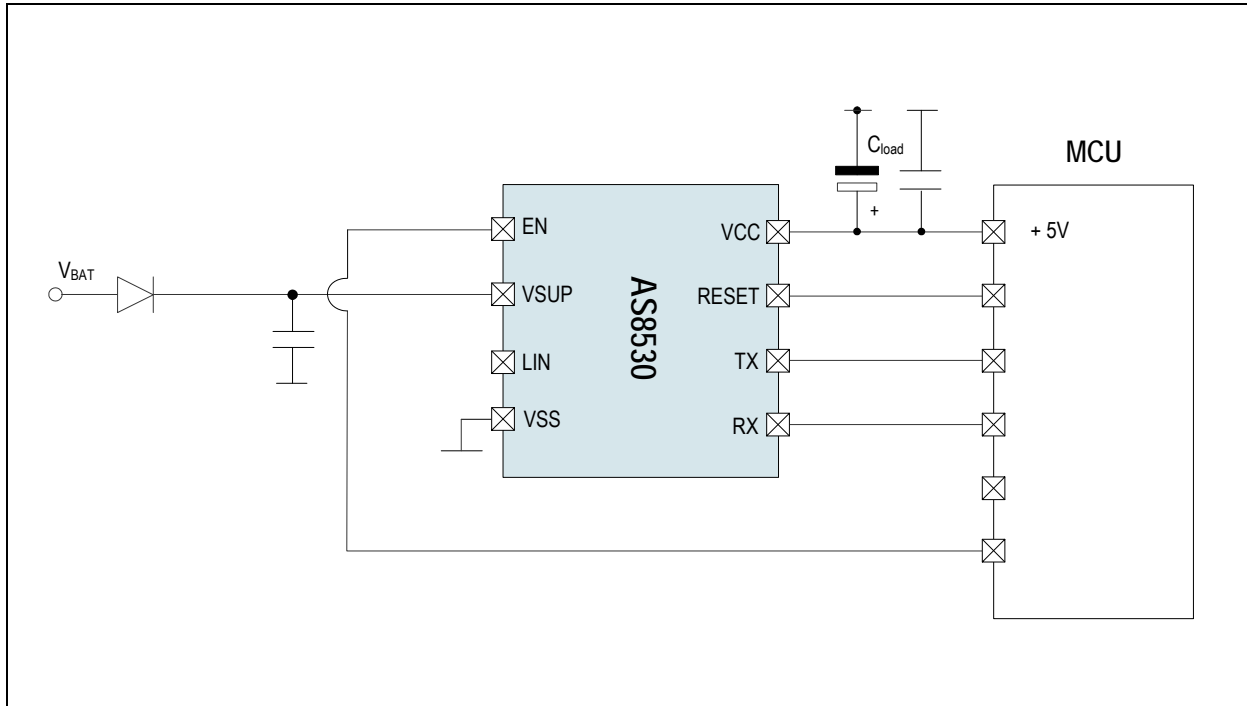

If the application doesn't need the wake up capability of the AS8530, a direct connection EN to VCC is possible. In this case the AS8530 operates in permanent normal mode. Also possible is the external (outside of the module) control of the EN line via. VSUP signal as shown below.

Figure 13. Permanent Normal Mode

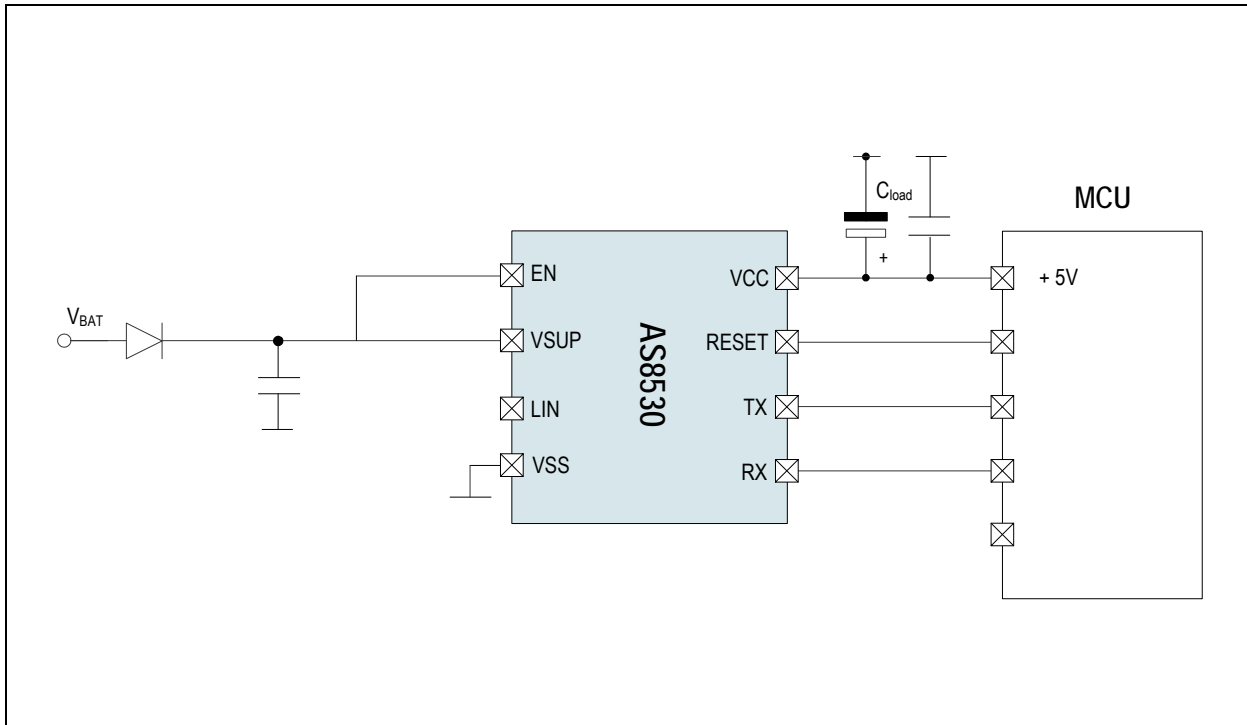

## 8.7 Serial Port Interface

The interface is essentially used to trigger the window watchdog, to access test mode and read out diagnostic information for the AS8530. The description of this interface and the protocol is explained below. Information on block status and errors can be displayed by diagnosis registers.

### 8.7.1 Device Configuration using 2-Wire Serial Port

The AS8530 device configuration register is programmed via a 2-wire Serial Programming Interface. EN/SCL is used as Serial Clock and TX/SDA\_IO is used as Serial Data. EN is used as clock input to access serial port registers in serial port mode. Also EN is used to control transition from normal mode to standby/sleep mode. The TX input of the device will be multiplexed as following:

- LIN TX for transmitting data from microcontroller on LIN bus
- SDA\_IO for Serial data input/output, this will be used for serially accessing data from configuration and status register

**SP Frame.** A frame is formed by first byte for command and address/configuration and following bit stream that can be formed by an integer number of bytes. Command is coded RD/WR on the first bits, length of the transfer is indicated by LEN1, LEN2 bits while address is given on LSB 5 bits.

Table 6. Command Bits

Command Bits			Register Address or Transmission Configuration				
RD/WR	LEN1	LEN2	A4	A3	A2	A1	A0

RD/WR	Command	<A4:A0>	Description
0	WRITE	ADDRESS	Writes data byte on the given starting address.
1	READ	ADDRESS	Read data byte from the given starting address.

Table 7. Transfer Length

LEN1	LEN2	Length	Description
0	0	1	Transfer consists of single Data phase. After completion of single Data phase device comes out of Serial port interface.
0	1	2	Transfer consist of two Data phase.
1	0	4	Transfer consist of four Data phase.
1	1	8	Transfer consist of eight Data phase.

**Write Command.** For Write command RD/WR = 0

After the command code, length of the transfer is send in next two bits, the address of register to be written has to be provided from the MSB to the LSB. Then one, two, four, or eight data bytes can be transferred from the MSB to the LSB. For each data byte following the first one, used address is the incremented value of the previously written address. Each bit of the frame has to be driven by the 2-Wire SP master on the SP clock (EN pin) positive edge and the 2-Wire SP slave (device) samples this bit on the next SP clock (EN pin) negative edge. In the following figures two examples of write command (without and with address self-increment).

Figure 14. Protocol for Serial Data Write with Length = 1

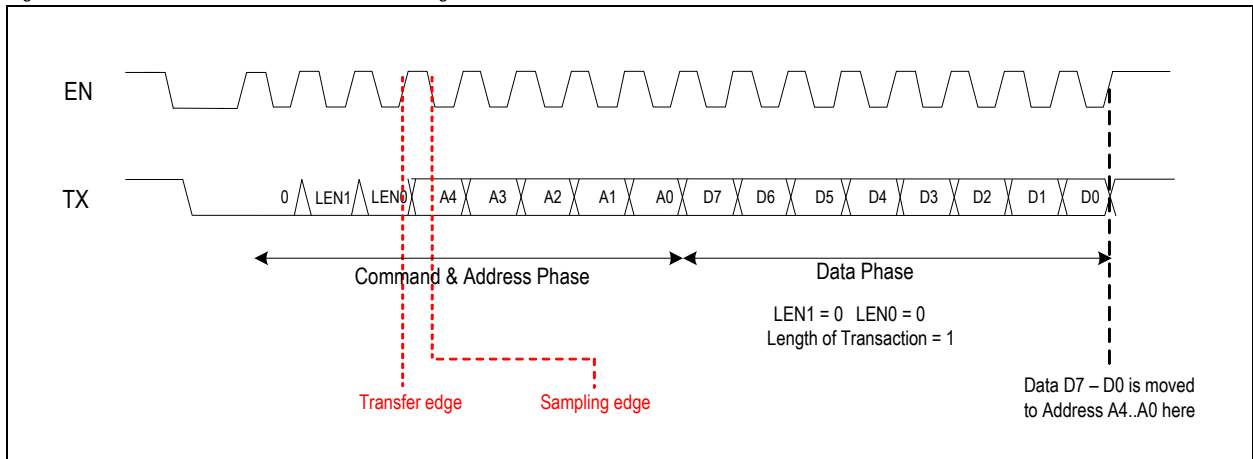
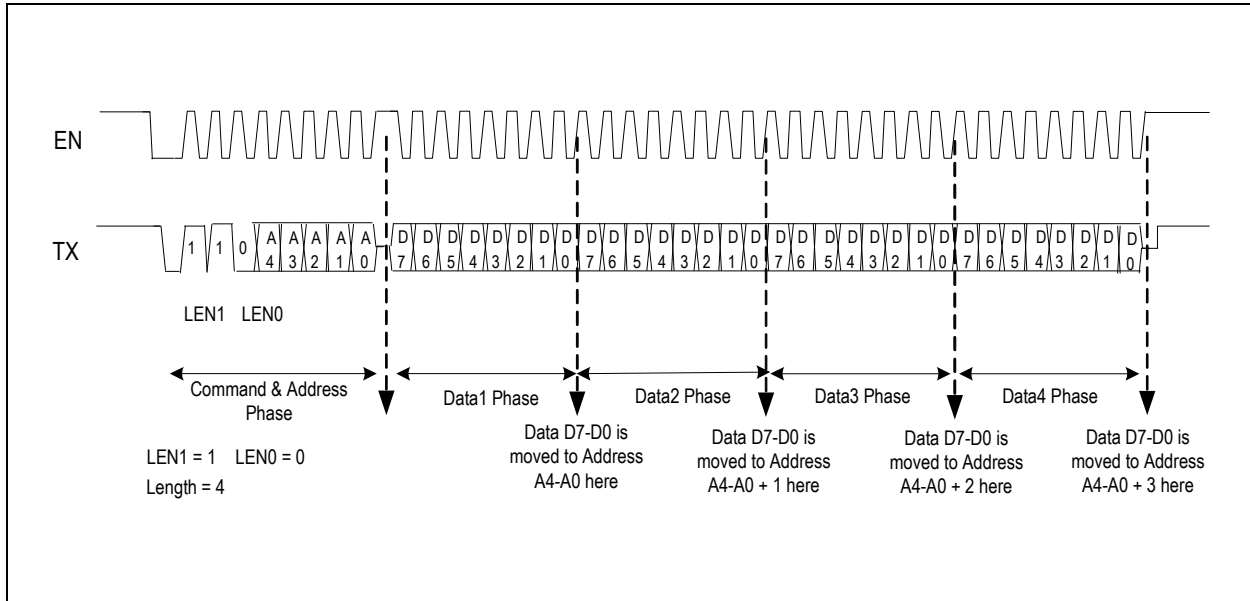

Figure 15. Protocol for Serial Data Write with Length = 4



**Read Command.** For Read command RD/WR=1.

After the command code, length of the transfer is send in next two bits, the address of register to be read has to be provided from the MSB to the LSB. Then one, two, four or eight data bytes can be transferred from the SPI slave to the master, always from the MSB to the LSB.

Each bit of the command and address sections of the frame have to be driven by the 2-Wire SP master on the SP clock (EN pin) positive edge and the 2-Wire SP slave (device) samples this bit on the next SP clock (EN pin) negative edge. Each bit of the data phase of the frame has to be driven by the 2-Wire SP slave (device) on the SP clock (EN pin) positive edge and the 2-Wire SP master samples this bit on the next SP clock (EN pin) negative edge. The following figures illustrate two examples of read command (without and with address self-increment.)

Figure 16. Protocol for Serial Data Read with Length = 1

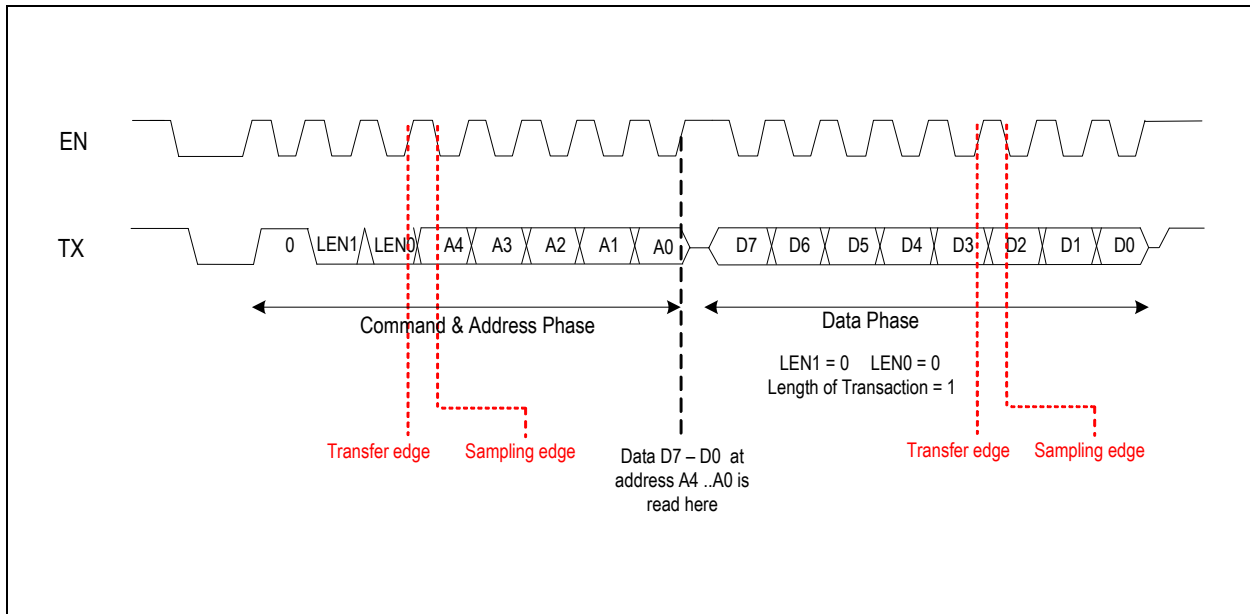
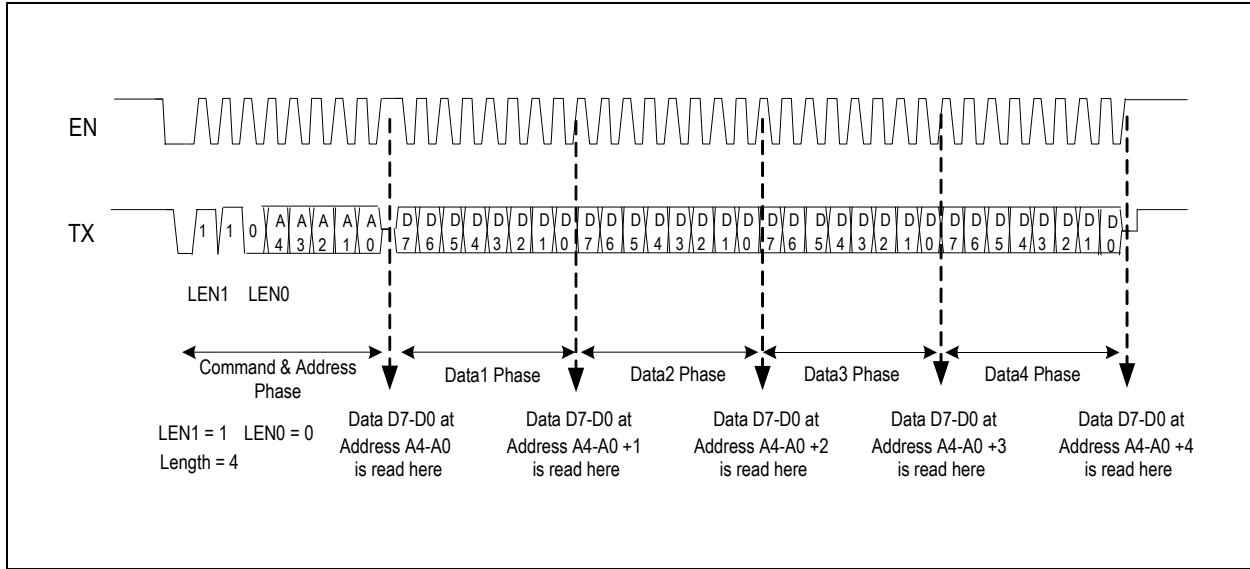

Figure 17. Protocol for Serial Data Read with Length = 4



**Timing.** The following figures illustrate timing waveforms and parameters.

Figure 18. Timing for Writing

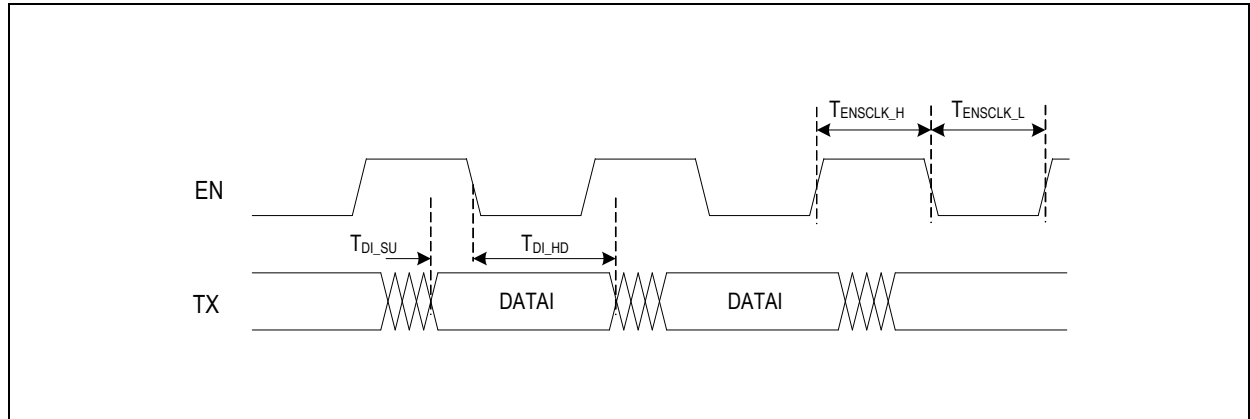
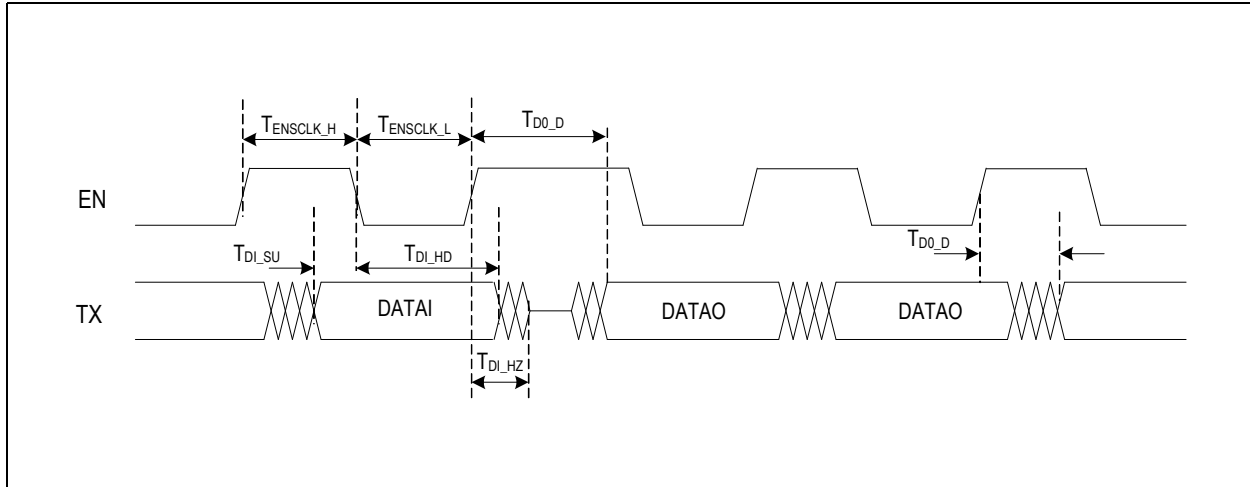

Figure 19. Timing for Reading



## 8.8 Control and Diagnosis Registers

The serial interface can be used as interface between the ASSP AS8530 and an external micro-controller. The interface is a slave and only the micro-controller can start the communication. This interface will be used for device configuration, entering into test mode and carrying out diagnostic options. Refer to [Table 8](#) for details on the configuration registers.

### 8.8.1 Definition of Control and Status Registers

A total of 32 control, diagnosis and test registers, each of 8-bit can be accessed using the 2-wire serial interface. [Table 8](#) provides a description of all control and status registers.

Table 8. Configuration Registers

Address	Register Name	POR Value	RD / WR	Description
<b>Control and Configuration Register</b>				
0 x 03	Device Configuration Register	On POR_VCC 0000_1111	RD / WR	D0 Reserved
				D1 Reserved
				D2 Reserved
				D3 Enable / Disable LIN Transceiver
				0   Disabled
				1   Enabled
				D7...D4 Reserved
0 x 04	Device Control Register	On POR_VSUP 0000_0001	RD / WR	D7... D1 Reserved
0 x 05	Temporary Shutdown Register	On POR_VCC 0000_0000	RD / WR	D0 Temporary shutdown control bit
				0   No Temporary shutdown
				1   Enter into Temporary shutdown
				D7...D1 Reserved
0 x 06	Window Watch Dog Trigger Register	On POR_VCC 0000_0000	WR	D0 Window Watch Dog Trigger
				This bit will be set by MCU to indicate trigger event. If this trigger occurs outside the Window of Watch dog counter, then RESET signal is asserted. Also on this trigger WWD counter is restarted and this bit will be cleared internally within 2 cycles of 128KHz clock.
				D7 ... D1 Reserved
0 x 07	Low Side Driver Data Register	On POR_VCC 0000_0000	RD / WR	D7 ... D0 Reserved

Table 8. Configuration Registers

Address	Register Name	POR Value	RD / WR	Description
Diagnosis Register				
0 x 08	Diagnostic Register 1	On POR_VSUP 0000_0011	RD	D7..D0 = DR[7:0] 8 LSB bits of the 24 bit Diagnostic Register
				D0 PORVSUP (set when VSUP < Vsuvr_on, cleared after $\mu$ C read)
				D1 UVVCC Under voltage VCC (set when VCC < Vuvr_on, cleared after $\mu$ C read)
				D2 OTEMP160 Over-temperature Reset. (set when temp > T <sub>sd</sub> , cleared after $\mu$ C read)
				D3 OTEMP140 Over-temperature warning (set when temp > T <sub>otset</sub> , cleared after $\mu$ C read)
				D4 OVVBAT Overvoltage VBAT. (set when VSUP > Vovthh, cleared after $\mu$ C read)
				D5 Reserved
				D6 RWAKE Remote Wakeup (set on Remote Wakeup event on LIN Bus, cleared after $\mu$ C read)
0 x 09	Diagnostic Register 2	On POR_VSUP 0000_0000	RD	D7..D0 = DR[15:8] next 8 LSB bits of the 24 bit Diagnostic Register.
				D0 TXTIMEOUT Tx timeout of 1sec. (set on TX low > 1sec, cleared after $\mu$ C read)
				D1 TEMPSHUT this bit is set on entering into temporary shutdown state and cleared after $\mu$ C read.
				D7 D2 Reserved

**Note:** When the device is powered ON @ ambient temperature of 125°C, the status of the OVTEMP140 can be HIGH indicating an over temperature warning. This is because 125°C is within the limits for the OVTEMP140.

# 9 Package Drawings and Markings

The device is available in a ep-SOIC8 package.

Figure 20. Drawings and Dimensions

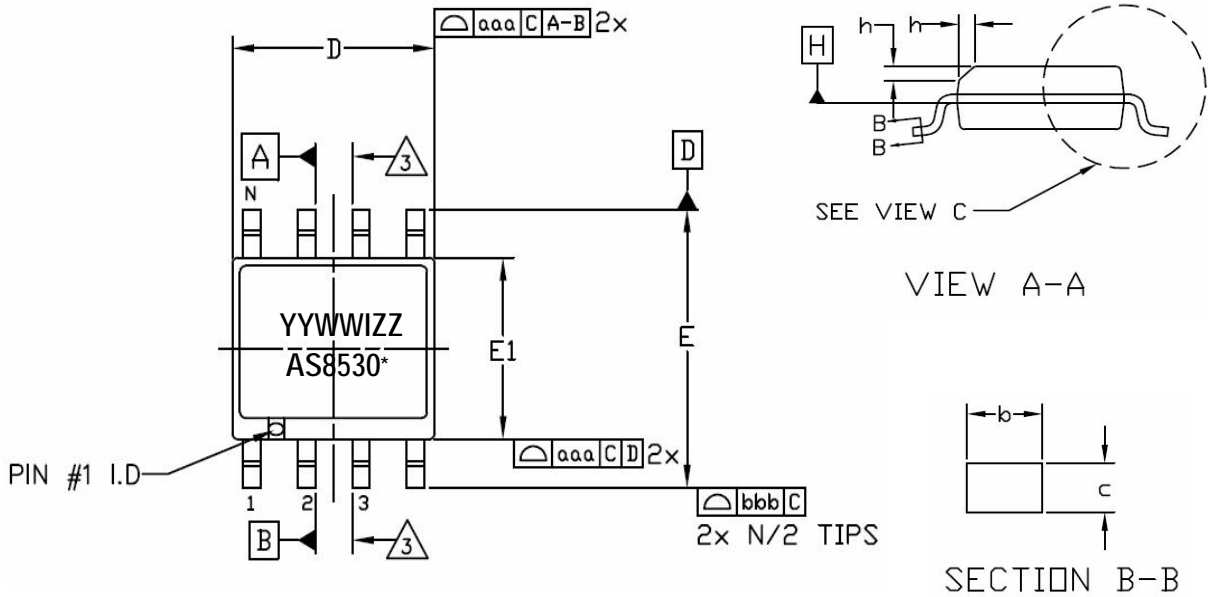

\* The device marking for the VCC=5V option will change to AS8530A.

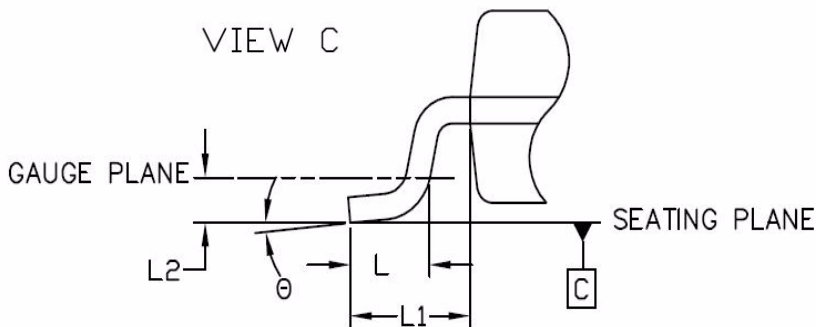
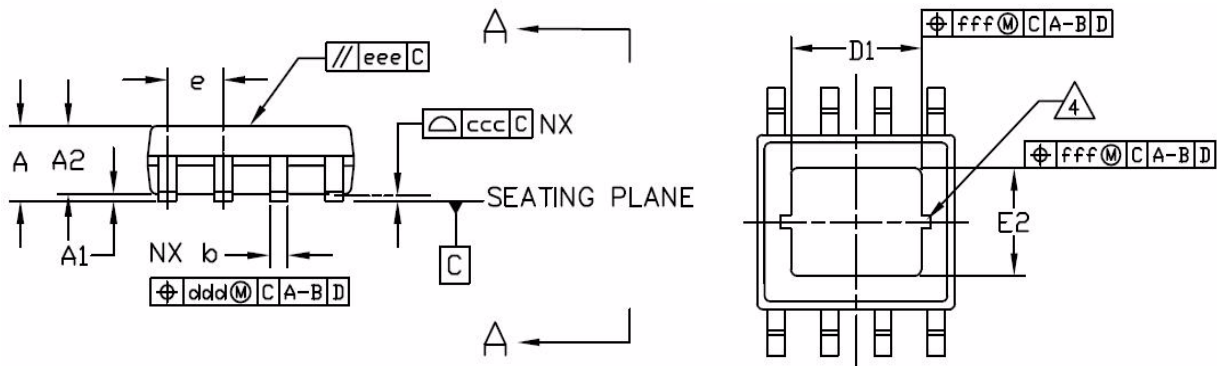

Symbol	Min	Nom	Max
A	-	-	1.70
A1	0.00	-	0.15
A2	1.25	-	-
b	0.31	-	0.51
c	0.17	-	0.25
D	-	4.90 BSC	-
D1	2.24	3.10	3.20
E	-	6.00 BSC	-
E1	-	3.90 BSC	-
E2	1.55	2.41	2.51
e	-	1.27 BSC	-
L	0.41	0.64	0.89

Symbol	Min	Nom	Max
L1	-	1.04 REF	-
L2	-	0.25 BSC	-
h	0.25	-	0.50
$\theta$	0°	-	8°
aaa	-	0.10	-
bbb	-	0.20	-
ccc	-	0.10	-
ddd	-	0.25	-
eee	-	0.10	-
fff	-	0.15	-
N	8		

**Notes:**

1. Dimensions and tolerancing conform to *ASME Y14.5M -1994*.
2. All dimensions are in millimeters. Angles are in degrees.
3. Datums A and B to be determined at datum H.
4. Extrusion of exposed area in bottom side is 0.20mm typical.

**Marking:** YYWWIZZ.

YY	WW	I	ZZ
Last two digits of the manufacturing year	Manufacturing Week	Plant Identifier	Traceability Code

## Revision History

Revision	Date	Owner	Description
1.0	26 Nov, 2010	mbl	Initial release
	29 Nov, 2010	kpt	Marking details updated under Ordering Information.
1.1	03 Jun, 2011	mbl	Updated Package Drawings and Markings, Ordering Information.

**Note:** Typos may not be explicitly mentioned under revision history.

## 10 Ordering Information

The devices are available as the standard products shown in [Table 9](#).

Table 9. Ordering Information<sup>1</sup>

Ordering Code	Marking	Description	Delivery Form	Package
AS8530A-ASOT	AS8530A	VCC = 5V	Tape & Reel	ep-SOIC8
AS8530-ASOT	AS8530	VCC = 3.3V	Tape & Reel	ep-SOIC8

1. For both product versions, the RESET delay time  $t_{Res}$  as well as undervoltage threshold are set to default value and window watchdog is disabled. On special request, optional factory settings can be made available on specific vendor addendum.

**Note:** All products are RoHS compliant and austriamicrosystems green.

Buy our products or get free samples online at ICdirect: <http://www.austriamicrosystems.com/ICdirect>

Technical Support is available at <http://www.austriamicrosystems.com/Technical-Support>

For further information and requests, please contact us [mailto: sales@austriamicrosystems.com](mailto:sales@austriamicrosystems.com) or find your local distributor at <http://www.austriamicrosystems.com/distributor>

## Copyrights

Copyright © 1997-2011, austriamicrosystems AG, Tobelbaderstrasse 30, 8141 Unterpremstaetten, Austria-Europe. Trademarks Registered ®. All rights reserved. The material herein may not be reproduced, adapted, merged, translated, stored, or used without the prior written consent of the copyright owner.

All products and companies mentioned are trademarks or registered trademarks of their respective companies.

## Disclaimer

Devices sold by austriamicrosystems AG are covered by the warranty and patent indemnification provisions appearing in its Term of Sale. austriamicrosystems AG makes no warranty, express, statutory, implied, or by description regarding the information set forth herein or regarding the freedom of the described devices from patent infringement. austriamicrosystems AG reserves the right to change specifications and prices at any time and without notice. Therefore, prior to designing this product into a system, it is necessary to check with austriamicrosystems AG for current information. This product is intended for use in normal commercial applications. Applications requiring extended temperature range, unusual environmental requirements, or high reliability applications, such as military, medical life-support or life-sustaining equipment are specifically not recommended without additional processing by austriamicrosystems AG for each application. For shipments of less than 100 parts the manufacturing flow might show deviations from the standard production flow, such as test flow or test location.

The information furnished here by austriamicrosystems AG is believed to be correct and accurate. However, austriamicrosystems AG shall not be liable to recipient or any third party for any damages, including but not limited to personal injury, property damage, loss of profits, loss of use, interruption of business or indirect, special, incidental or consequential damages, of any kind, in connection with or arising out of the furnishing, performance or use of the technical data herein. No obligation or liability to recipient or any third party shall arise or flow out of austriamicrosystems AG rendering of technical or other services.



## Contact Information

### Headquarters

austriamicrosystems AG  
Tobelbaderstrasse 30  
A-8141 Unterpremstaetten, Austria

Tel: +43 (0) 3136 500 0  
Fax: +43 (0) 3136 525 01

For Sales Offices, Distributors and Representatives, please visit:

<http://www.austriamicrosystems.com/contact>