

AS3685C

Ultra Small High Efficiency 1000mA Charge Pump for White LED Flash with Two Wire Serial Interface

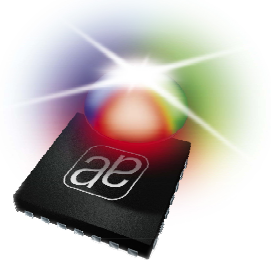

1 General Description

The AS3685 is low noise high efficiency capacitive charge pump with 1:1, 1:1.5 and 1:2 operating modes in a small 3x3mm DFN10 or a tiny 2x1.5mm WL-CSP (Wafer Level Chip Scale Package) package. It can drive one flash led at up to 1000mA current. It supports flash/torch and indicator mode for the flash led.

Additionally the AS3685 limits the flash time automatically to protect the flash LED.

2 Key Features

- High Efficiency capacitive charge pump with 1:1, 1:1.5 and 1:2 modes
 - 1:2 Mode can be disabled by interface
- Up to 1000mA Led Current
- Automatic Charge Pump Mode switching (Up)

- LED cathode disconnect in Shutdown
- Overtemperature Protection
- Automatic Flash Timeout to protect the LED
 - Adjustable between off, 100ms...1500ms
- Two Wire Interface
 - Accurate Control of Currents and Modes
- Package
 - DFN10 3x3mm (10 pins + exposed pad)
 - WL-CSP (Wafer Level Chip Scale Package) 3x4 balls 0.5mm pitch (2x1.5mm)

3 Applications

- Flash / Torch for Mobile Phones, Digital Cameras and PDA

4 Application Diagram

Figure 1 – Application Diagram of AS3685C

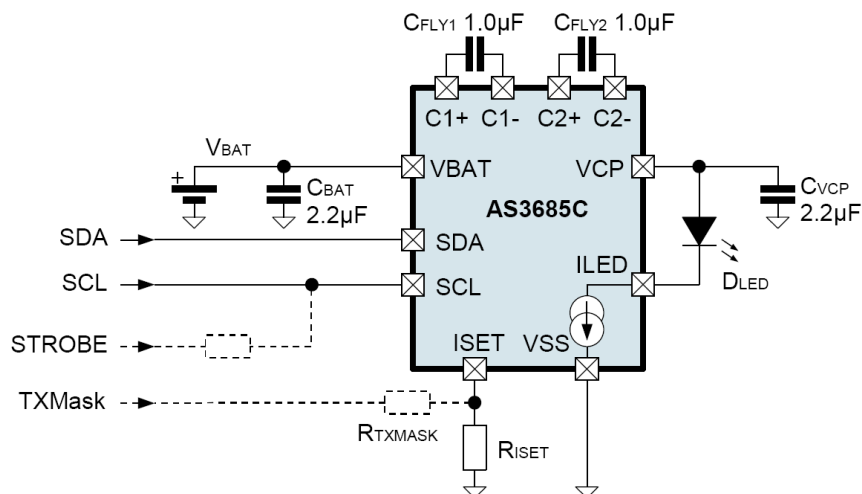

Table of Contents

1	General Description	1
2	Key Features	1
3	Applications	1
4	Application Diagram	1
5	Characteristics	3
	5.1 Absolute Maximum Ratings	3
	5.2 Operating Conditions	3
	5.3 Electrical Characteristics	4
6	Typical Operation Characteristics	6
7	Detailed Functional Description	8
	7.1 Low Noise Charge Pump	8
	7.1.1 Mode Switching	8
	7.1.2 Soft Start	9
	7.2 Current Source (Sink)	9
	7.2.1 AS3685 TXMask Function	12
	7.3 Protection Functions	13
	7.3.1 Overtemperature Protection	13
	7.3.2 Flash Timeout	13
	7.4 Layout Recommendations	13
8	External Components	14
	8.1 Capacitor and Resistor Selection	14
	8.2 Usage of PCB Wire Inductance	14
	8.3 External Component Specifications	14
9	Pinout and Packaging	15
	9.1 DFN10 3x3mm	15
	9.1.1 Pin Assignments DFN10 3x3mm	15
	9.1.2 Pin Descriptions DFN10 3x3mm	15
	9.1.3 Package Drawings and Marking DFN10 3x3	16
	9.2 WL-CSP 2x1.5mm (Wafer Level Chip Scale Package)	18
	9.2.1 Pin Assignments WL-CSP 2x1.5mm	18
	9.2.2 Pin Descriptions WL-CSP 2x1.5mm	18
	9.2.3 Package Drawings and Marking WL-CSP 2x1.5mm	19
10	Ordering Information	20

5 Characteristics

5.1 Absolute Maximum Ratings

Stresses beyond those listed in Table 1 may cause permanent damage to the device. These are stress ratings only, and functional operation of the device at these or any other conditions beyond those indicated in Section 5 Electrical Characteristics is not implied.

Exposure to absolute maximum rating conditions for extended periods may affect device reliability.

Table 1 – Absolute Maximum Ratings

Symbol	Parameter	Min	Max	Unit	Note
VBATMAX	Maximum Supply Voltage	-0.3	7.0	V	
IIN	Input Pin Current without causing latchup	-25	+25	mA	At 25°C, Norm: Jedec 17
TSTRG	Storage Temperature Range	-55	125	°C	
	Humidity	5	85	%	Non condensing
VESD	Electrostatic Discharge	-1000	1000	V	Norm: MIL 883 E Method 3015
PT	Total Continuous Power Dissipation		1.14	W	DFN10 3x3mm, TA = 70°C ¹
			1.02	W	WL-CSP 2x1.5mm, TA = 70°C ¹
PDERATE	PT Derating Factor ²		16.3	mW/°C	DFN10 3x3mm
			14.7	mW/°C	WL-CSP 2x1.5mm
TJUNC	Junction Temperature		150	°C	
TBODY	Body Temperature during Soldering		260	°C	according to IPC/JEDEC J-STD-020

Notes:

1. Depending on actual PCB layout and PCB used; for peak power dissipation during flashing see document 'AS3685 Thermal Measurements'
For 1A flash current see application notes 'AN3685_1Aflash' and 'AN3685_1Aflash_thermal_1v0'.
2. The PT derating factor changes the total continuous power dissipation, if the ambient temperature is different to 70°C. Therefore for e.g. 85°C calculate $PT_{85°C} = PT - PDERATE * (85°C - 70°C)$

5.2 Operating Conditions

Table 2 – Operating Conditions

Symbol	Parameter	Min	Typ	Max	Unit	Note
VBAT	Battery Supply Voltage	3.0	3.6	5.5	V	Supply voltage range
VBATFUNC	Battery Supply Voltage, Functionally working	2.6			V	AS3685 functionally working, but not all parameters fulfilled
IBAT	Operating Current			0.4	A	Depending on load current and charge pump mode
				2.0	A	Limited lifetime, max 20,000s
TAMB	Ambient Temperature	-30	25	85	°C	
I _{OFF}	Off mode current		1.0	4.0	μA	Mode setting=off; VBAT<=4.2V

Table 2 – Operating Conditions

Symbol	Parameter	Min	Typ	Max	Unit	Note
IOPERATING	Power Consumption without load		0.85		mA	1:1 Mode
			6.6		mA	1:1.5 Mode
			8.1		mA	1:2 Mode

5.3 Electrical Characteristics

Table 3 – Charge Pump Characteristics

Symbol	Parameter	Min	Typ	Max	Unit	Note
VCP _{OUT}	V(VCP) Output voltage without load – do not short to VSS			V _{BAT} * CP-mode	V	CP-mode is 1, 1.5 or 2 (automatically selected)
	Output limitation		5.4	5.6		internally limited
R _{CP}	Charge Pump effective Resistance		0.28	0.53	Ω	1:1 Mode V _{BAT} = 3.6V, I _{CPOUT} = 200mA
			1.37	2.00	Ω	1:1.5 Mode V _{BAT} = 3.3V, I _{CPOUT} = 500mA, T _{JUNCTION} ≤ 85°C
			1.95	2.44	Ω	1:2 Mode V _{BAT} = 3.0V, I _{CPOUT} = 700mA, T _{JUNCTION} ≤ 85°C
η	Efficiency	75		93	%	V _{in} = 3.0V-4.5V, I _{out} = 100mA (Charge Pump alone)
V _{RI}	Output ripple voltage		100		mV _{pp}	V _{in} = 3.0-4.5V, I _{out} = 350mA,
f _{clk}	Operating Frequency	-20%	1.0	+20%	MHz	
t _{UP_DEB_LONG}	Initial Mode Switching Debounce Time		256		μs	Mode switching up-debounce time after enabling of the charge pump or after mode switching between 1:1 to 1:1.5
t _{UP_DEB}	Mode Switching Debounce Time		16		μs	Mode switching up-debounce time in normal operation

Table 4 – Current Source (Sink) Characteristics

Symbol	Parameter	Min	Typ	Max	Unit	Note
I _{LED}	Output Current Range		700	1000	mA	700mA: R _{SET} = 14.2kΩ 1000mA: R _{SET} = 10kΩ
I _{ACCURACY}	Current Setting Accuracy	-10%	500	+10%	mA	Measured with R _{SET} = 19.9kΩ and maximum flash current
I _{INDICATOR}	Indicator Current setting		1.0		mA	
V _{ISET}	Current Generator Set Point Voltage (pin ISET)		1.3		V	I _{SET} = V _{ISET} / R _{SET}
I _{ISET}	Current Generator operating range	10.0		130	μA	if the resulting bias current is higher than 200μA (typ.), the current source is disabled
I _{FLASH2ISET}	Flash Current to Bias Current Ratio		7650		A/A	At full flash current (700mA with R _{SET} = 14.2kΩ)
V _{SWITCH}	Mode Switching Threshold on V(I _{LED}) between 1:1 -> 1:1.5 and 1:1.5 -> 1:2	350	400	450	mV	Data1 <7:0> (flash LED current) ≥ 0x80h in flash mode; I _{LED} > 350mA @ R _{SET} = 14.2kΩ

Table 4 – Current Source (Sink) Characteristics

Symbol	Parameter	Min	Typ	Max	Unit	Note
		150	200	250	mV	All lower currents

Table 5 – Digital Interface characteristics

Symbol	Parameter	Min	Typ	Max	Unit	Note
V _{IH}	High Level Input voltage	1.5		V _{BAT}	V	For Pins SCL and SDA
V _{IL}	Low Level Input voltage	0.0		0.5	V	
I _{LEAKAGE}	Input pin leakage current	-10		10	μA	

Table 6 – Protection Functions

Symbol	Parameter	Min	Typ	Max	Unit	Note
T _{OVTEMP}	Overtemperature protection		140		°C	If the junction temperature exceeds T _{OVTEMP} , the current sink will be disabled and the charge pump switched back into 1:1 mode until the temperature drops below T _{OVTEMP} - T _{OVTEMPHYST}
T _{OVTEMPHYST}	Overtemperature protection Hysteresis		5		°C	
t _{FLASHTIMEOUT}	Flash Timeout Time	-20%	100... 1500	+20%	ms	adjustable by register Flash Timeout Timer

6 Typical Operation Characteristics

Figure 2 – Efficiency vs. Battery Voltage (with Lumiled PWF1)

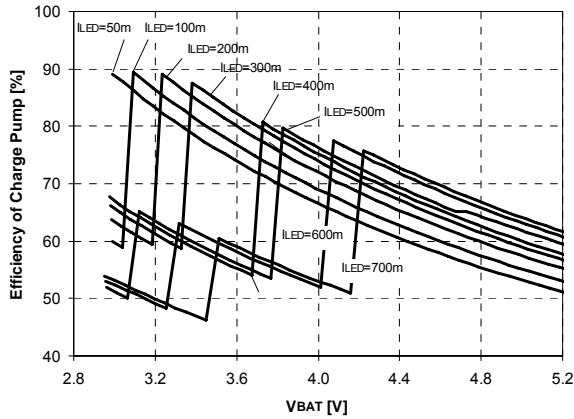

Figure 3 – Battery Current vs. Battery Voltage (with Lumiled PWF1)

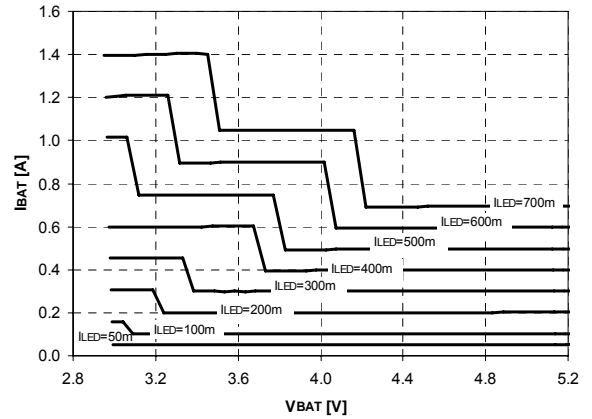

Figure 4 – LED current I(ILED) vs. Battery Voltage (with Lumiled PWF1)

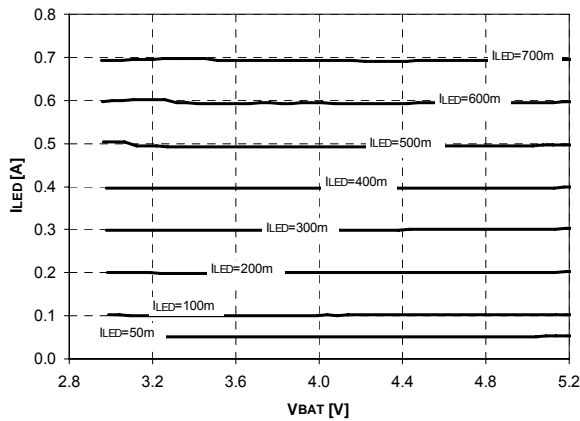

Figure 5 – Linearity of Current Sink

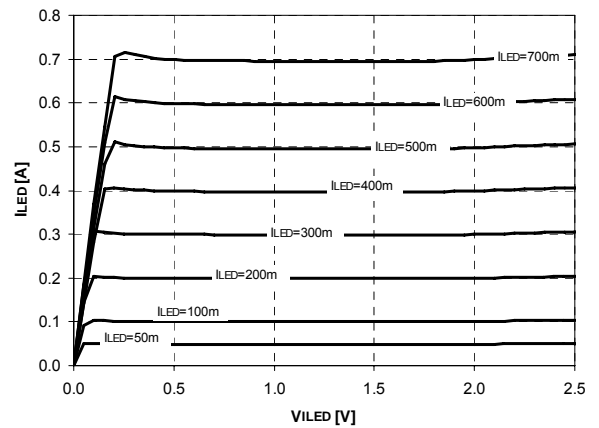

Figure 6 – I(ILED) vs. R(ISET)

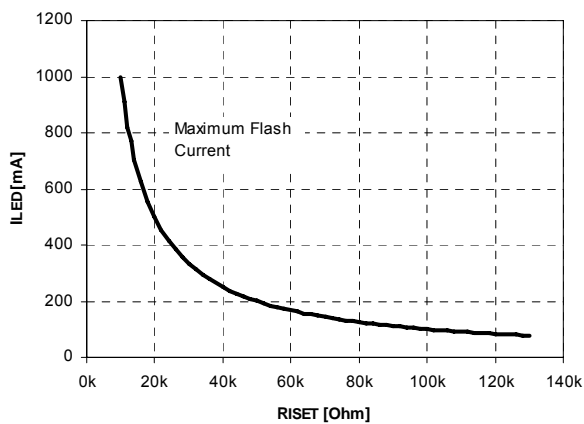

Figure 7 – Typical Operating Waveforms 1:1.5 Mode

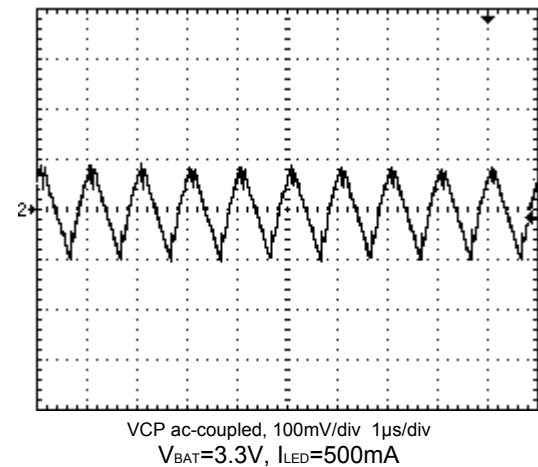
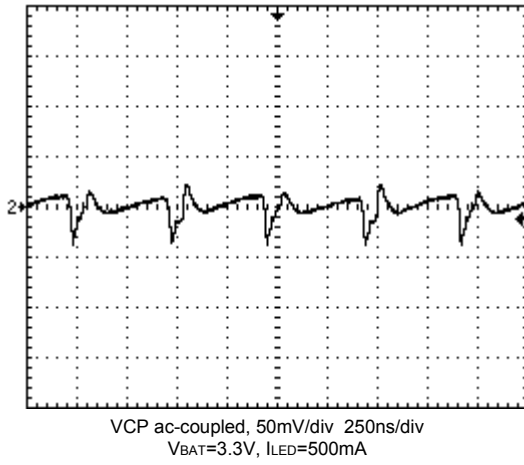
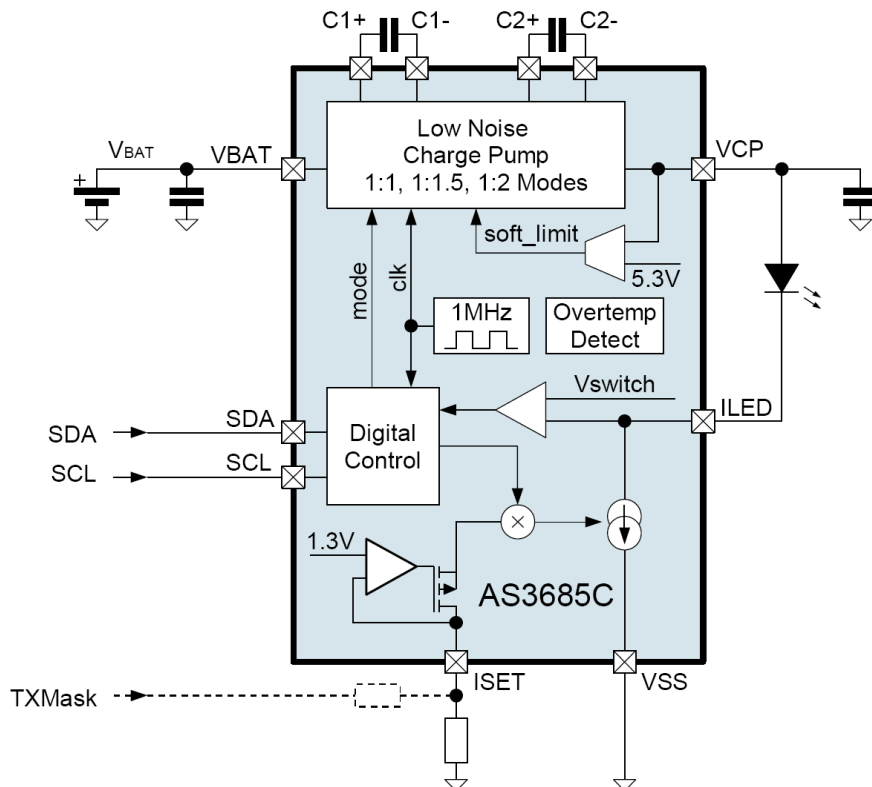

Figure 8 – Typical Operating Waveforms 1:2 Mode



7 Detailed Functional Description

Figure 9 – Internal Circuit Diagram of AS3685C



7.1 Low Noise Charge Pump

The AS3685 charge pump uses two external flying capacitors to generate output voltages higher than the battery voltage. The charge pump can operate in three different modes:

- 1:1 Bypass Mode or Off Mode
 - Battery input and output are connected by a low-impedance switch
 - Battery current = output current
- 1:1.5 Mode
 - The output voltage is 1.5 times the battery voltage (without load)
 - Battery current = 1.5 times output current
- 1:2 Mode
 - The output voltage is 2 times the battery voltage (without load)
 - Battery current = 2 times output current

The flying capacitors are switched at the fixed frequency f_{clk} .

7.1.1 Mode Switching

The AS3685 monitors the voltage at the current sink $V(I_{LED})$ and if this voltage falls below V_{SWITCH} , for a time longer than the debounce time, the charge pump automatically switches into a higher mode. The debounce time is set to $t_{UP_DEB_LONG}$ at enabling of the charge pump or immediately after a 1:1 to 1:1.5 mode change. Afterwards the debounce time is reduced to t_{UP_DEB} . (This allows the LED current to settle properly on startup or after a mode change)

The charge pump enters always 1:1 mode in off mode or in case of overtemperature.

It is possible to avoid the 1:2 mode (register programmable) to limit the battery current to 1.5 times the output (=LED) current.

7.1.2 Soft Start

The soft start mechanism reduces the inrush current. Battery current is smoothed when switching the charge pump on and also at each switching condition. This precaution reduces electromagnetic radiation significantly.

7.2 Current Source (Sink)

The AS3685 operates in three different modes:

- Indicator Mode: A small (average) current is used to obtain an indication function with the flash LED (e.g. indication for camera operation)
- Torch Mode: A moderate current of e.g. 150mA allows the use of the flash LED as a torch or video light
- Flash Mode: A high current of e.g. 700mA (up to 1000mA) is set for a high brightness flash. Only in this mode, the flash timeout timer limits the total flash time.

The current through the LED and the operating mode is controlled by the two digital interface connected to SCL and SDA.

The current is controlled with a two wire bus interface commands similar to I2C communication (device address 82h, only commands writing to the AS3685 are possible, no readback) as shown in following figure:

Figure 10 – Two wire interface waveform

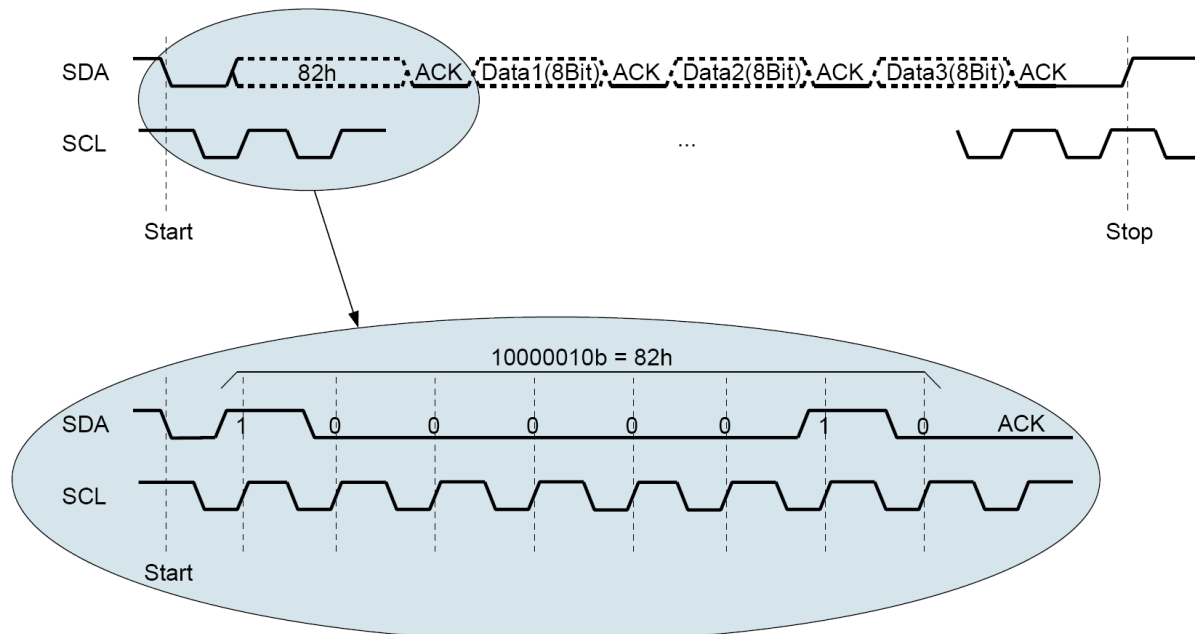

Data from the bus is always captured on the rising edge of the SCL signal; therefore the data on SDA has to be stable slightly before this rising edge.

The strobe command is merged with the interface commands and all other devices connected to the bus will ignore these commands. Only the AS3685 will also use these commands and switch on/off the flash led with the strobe pin (The strobe function can be enabled/disabled by the interface and its polarity is selectable):

Figure 11 – External circuit of the AS3685 using active High strobe function

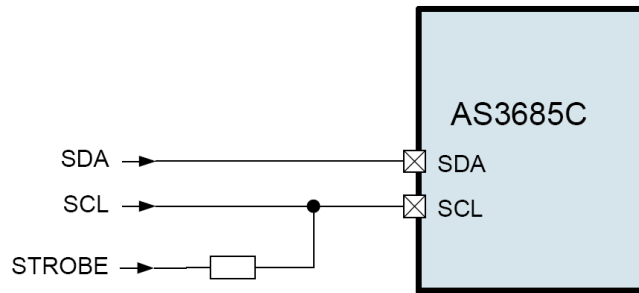

Using the above external circuit, an active strobe function can be implemented as follows:

Figure 12 – Timing Diagram of the AS3685 using active High strobe function

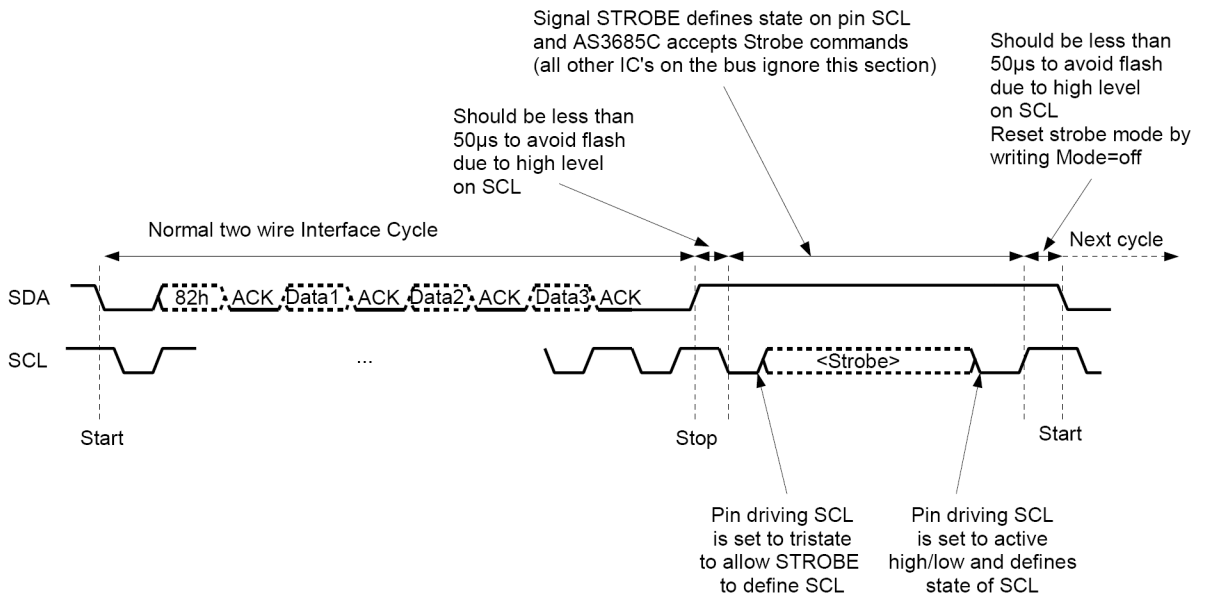

Alternatively (if the device driving SCL has only the possibility to pulldown the SCL line, but does not actively control high/low/tristate of the SCL line) use following circuit:

Figure 13 – External circuit of the AS3685 using active Low strobe function

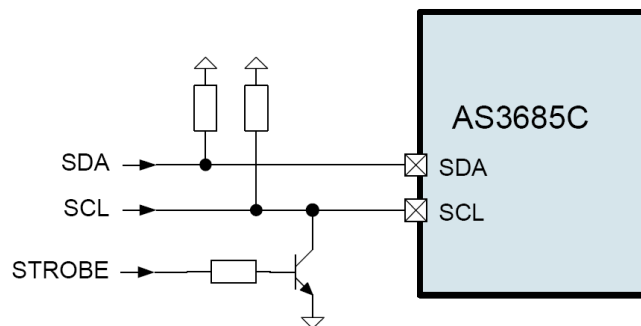

The control waveform is shown in the next figure:

Figure 14 – Timing Diagram of the AS3685 using active Low strobe function

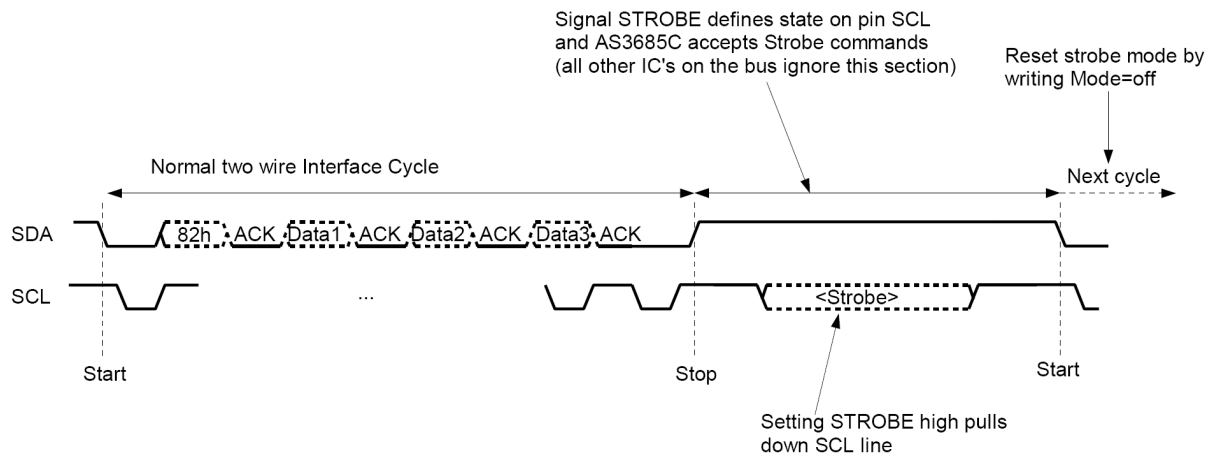

If the strobe function is not used at all, the interface can be addressed like a normal slave (only writing access). The strobe function does not violate the two wire interface specification.

Data1 setups the flash current from 0mA to 1000mA, Data2 can be used to set the preview current and Data3 will set the operating mode, can lock 1:2 charge pump mode and set or disable the flash mode timeout time.

Table 7 – Current and Mode Setting for the AS3685

Register	Purpose	Comments
Data1<7:0>	Current Setting Flash	Flash Mode current setting, Flash Timeout timer used if the mode setting uses this current 0mA to 1000mA (for R _{ISSET} =10kΩ) 0mA to 700mA (for R _{ISSET} =14.2kΩ)
Data2<6:0>	Current Setting Torch (Preview)	Torch (=Preview or Assist) Mode current setting, no timeout timer used for this current setting 0mA to 500mA (for R _{ISSET} =10kΩ) 0mA to 350mA (for R _{ISSET} =14.2kΩ)
Data2<7>	not used – leave at 0	not used
Data3<2:0>	Mode setting	000 ... Off (Power down; Charge Pump in 1:1 mode) 001 ... Indicator Mode Data2<7> = 0: ILED = 0.5mA Data2<7> = 1: ILED = 1.0mA 010 ... Torch (=Preview) Mode (Data2 sets current) 011 ... Flash Mode (Data1 sets current) 100 ... Preview / Flash Mode, STROBE active high STROBE=H: Flash mode (Data1 sets current) STROBE=L: Preview mode (Data2 sets current) 101 ... Preview / Flash Mode, STROBE active low STROBE=L: Flash mode (Data1 sets current) STROBE=H: Preview mode (Data2 sets current) 110 ... Force Charge Pump into 1:1.5 mode; no current is flowing through the current sink (AS3685 can be used as voltage generator for e.g. backlight LEDs with additional external current source(s)) 111 ... Force Charge Pump into 1:2 mode; no current is flowing through the current sink (AS3685 can be used as voltage generator for e.g. backlight LEDs with additional external current source(s))

Table 7 – Current and Mode Setting for the AS3685

Register	Purpose	Comments
Data3<3>	Avoid 1:2 Mode	0 ... Charge Pump can use 1:2 Mode 1 ... Charge Pump does not use 1:2 Mode; ignored if Data3<2:0> is set to 111 (forced 1:2 mode)
Data3<7:4>	Flash Timeout Timer	0000 ... Disable Timeout timer for Flash Mode 0001 ... 100ms Timeout timer for Flash Mode 0010 ... 200ms Timeout timer for Flash Mode ... 1111 ... 1500ms Timeout timer for Flash Mode

7.2.1 AS3685 TXMask Function

If the battery has to supply two high currents at the same time (e.g. the AS3685 flash and a RF-power amplifier) it is possible, that the total current causes a high voltage drop on the battery resulting in a shutdown of the complete system. In order to avoid this shutdown, the AS3685 (AS3685A or AS3685B) can reduce its current with the signal 'TXMask' using the following circuit:

Figure 15 – TXMask function of the AS3685

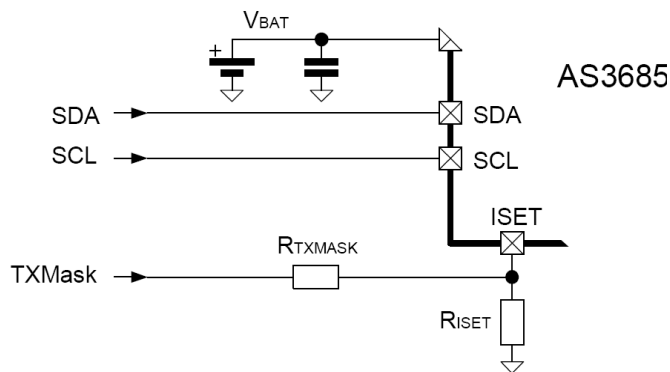

The TXMask signal is connected to e.g. the (RF-) power amplifier enable pin (active high if the PA is enabled). This reduces the flash current if the power amplifier is enabled and avoids the unexpected shutdown of the system.

Note: The internal flash timeout timer ($t_{FLASHTIMEOUT}$) to limit the total flash duration, is not affected by the TXMask function (see also section 'Flash Timeout').

The ISET current (current into the pin ISET) for TXMask = 0 can be calculated with:

$$I_{ISET, TXMask=0} = \frac{V_{ISET}}{R_{ISET}} + \frac{V_{ISET}}{R_{TXMASK}} = \frac{1.3V}{R_{ISET}} + \frac{1.3V}{R_{TXMASK}}$$

For TXMask = 1 the current ISET is reduced to:

$$I_{ISET, TXMask=1} = \frac{V_{ISET}}{R_{ISET}} + \frac{V_{ISET} - V(TXMask)}{R_{TXMASK}} = \frac{1.3V}{R_{ISET}} + \frac{1.3V - V(TXMask)}{R_{TXMASK}}$$

$V(TXMask)$ is the actual voltage for the high level ('1') for the signal TXMask

The maximum flash current I_{LEDMAX} for TXMask=0 or 1 can be calculated according to the following formula using the above obtained ISET values:

$$I_{LEDMAX} = I_{FLASH2BIAS} I_{ISET} = 7650 \cdot I_{ISET}$$

Choose the values for R_{ISET} and R_{TXMASK} according to your application requirements.

7.3 Protection Functions

7.3.1 Overtemperature Protection

If the AS3685 junction temperature exceeds T_{OVTEMP} , the current sink will be disabled and the charge pump forced into 1:1 mode. If the junction temperature drops below $T_{OVTEMP} - T_{OVTEMPHYST}$, the device enables the current sink again and the charge pump resumes normal operation.

7.3.1.1 LED Shortcircuit protection

If the LED is shorted (VCP to ILED), then depending on the set current and the resulting high power dissipation inside the AS3685, the overtemperature protection will trigger. This protects the AS3685 and the system against damage. If the AS3685 is in off-mode, then shorting of the diode will have no influence on the system.

Note: Do not short VCP to VSS if the supply is not current limited (e.g. by an internal protection inside the battery), as there is an internal diode between VBAT (anode) and VCP (cathode).

7.3.2 Flash Timeout

The flash duration of a single flash is limited automatically to $t_{FLASHTIMEOUT}$ (applies only for 'Flash' mode(s)). This protects the flash LED against thermal damage.

7.4 Layout Recommendations

To improve the heat dissipation, use a massive ground plane.

Figure 16 – AS3685 DFN10 3x3mm Layout Recommendation

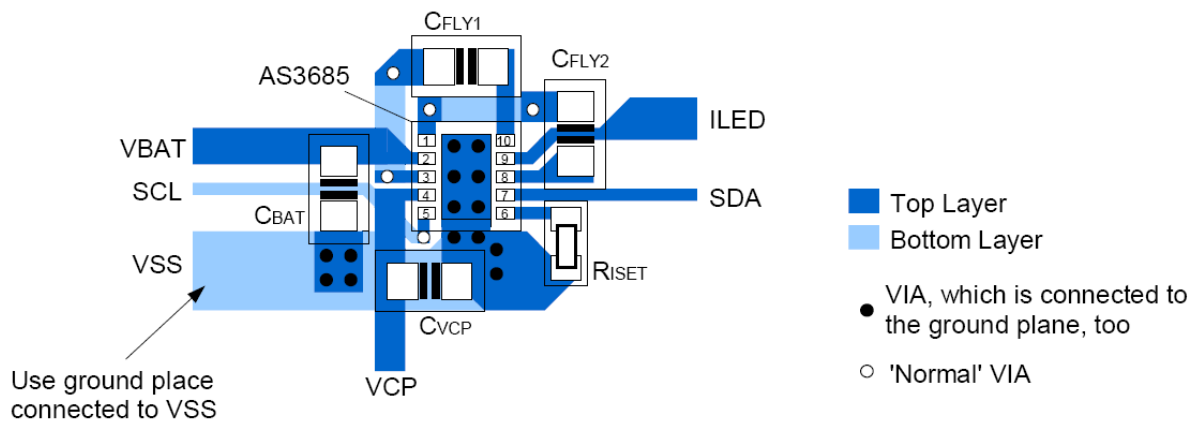
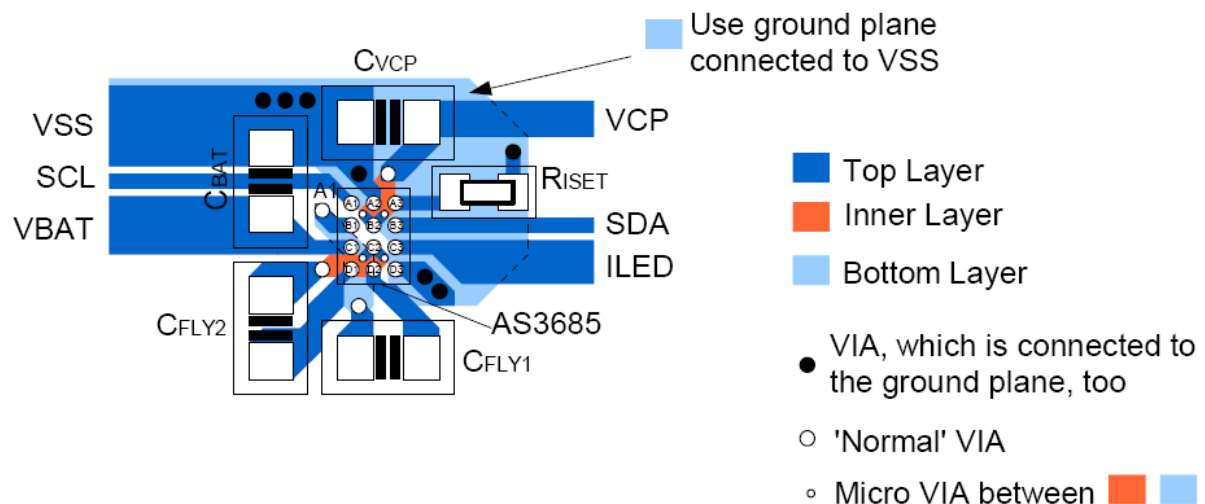

Figure 17 – AS3685 WL-CSP 2x1.5mm Layout Recommendation



8 External Components

8.1 Capacitor and Resistor Selection

Use low-ESR ceramic capacitors with X7R or X5R dielectric. These capacitors allow good filtering and have a wide temperature range. The connections of all external capacitors should be kept as short as possible. All resistors should have a tolerance of $\pm 1\%$.

8.2 Usage of PCB Wire Inductance

The inductance between the battery and pin VBAT can be used as a filter to reduce disturbance on the battery. Instead of using one capacitor (C_{BAT}) it is recommended to split C_{BAT} into C_{BAT1} and C_{BAT2} with the capacitance of

$$C_{BAT1} = C_{BAT2} = C_{BAT}$$

It is recommended to apply a minimum of 20nH (maximum 200nH) with low impedance. This inductance can be realized on the PCB without any discrete coil. Assuming that a 1mm signal line corresponds to approximately 1nH (valid if the length (L) is significantly bigger than the width (W) of the line ($L/W < 10$)), a line length of

$$20\text{mm} < L < 200\text{mm}$$

is recommended. The shape of the line is not important.

Figure 18 – PCB Wire Inductance Example1

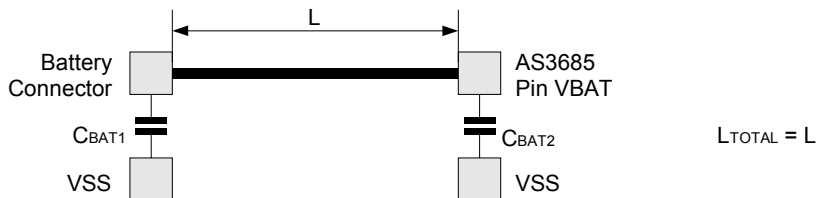
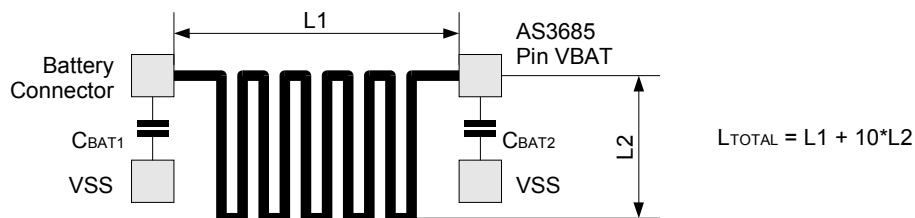

Figure 19 – PCB Wire Inductance Example2



8.3 External Component Specifications

Table 8 – External Components List

Part	Min	Value Typ	Max	Tol (Min)	Rating (Max)	Notes	Package (min)
C_{BAT}^1		2.2 μ F		+/-20%	6.3V	Ceramic, X5R e.g. Murata GRM21BR71A225KA01L	0603
CFLY1, CFLY2		1.0 μ F		+/-20%	6.3V	Ceramic, X5R e.g. Murata GRM188R60J105K	0603 (0402, 0405)
CVCP		2.2 μ F		+/-20%	6.3V	Ceramic, X5R e.g. Murata GRM21BR71A225KA01L	0603
RISSET	10k Ω		130k Ω	+/-1%		Current Set Resistor	0201
RTXMASK	See section 'TXMask function'			+/-1%		TXMask Set Resistor	0201
DLED	Flash Led						

Notes:

- See section 'Usage of PCB Wire Inductance'

9 Pinout and Packaging

9.1 DFN10 3x3mm

9.1.1 Pin Assignments DFN10 3x3mm

Figure 20 –Pin Assignments DFN10 3x3mm

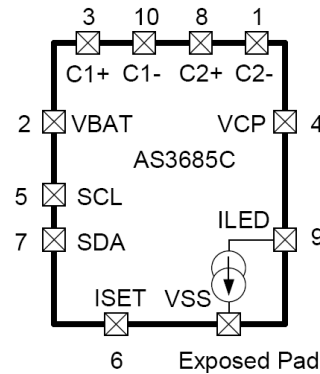

9.1.2 Pin Descriptions DFN10 3x3mm

Table 9 – Pin Type Descriptions DFN10 3x3mm

Pin Type	Description
AI/O	Analog Pin
DI	Digital Input
S	Supply Pin

Table 10 – Pin Descriptions DFN10 3x3mm

Pin Number	Pin Name	Type	Description
1	C2-	AI/O	Flying Capacitor 2 connection – connect 1 μ F ceramic capacitor C _{FLY2} between C2- and C2+
2	VBAT	S	Battery Supply Voltage
3	C1+	AI/O	Flying Capacitor 1 connection – connect 1 μ F ceramic capacitor C _{FLY1} between C1- and C1+
4	VCP	AI/O	Charge Pump Output voltage – connect flash LED anode to this pin and add C _{VCP} capacitor with 2.2 μ F to VSS
5	SCL	DI	Digital Control Signal two wire interface clock input
6	ISET	AI/O	Current Generator input pin – connect current set resistor R _{ISET} between this pin and VSS (and optional RTXMASK)
7	SDA	DI/O	Digital Input/Output Control two wire interface data signal
8	C2+	AI/O	Flying Capacitor 2 connection – connect 1 μ F ceramic capacitor C _{FLY2} between C2- and C2+
9	ILED	AI/O	Current Source input pin – connect flash LED cathode to this pin
10	C1-	AI/O	Flying capacitor 1 connection – connect 1 μ F ceramic capacitor C _{FLY1} between C1- and C1+
Exposed Pad	VSS	S	Ground Connection – a proper thermal connection with several vias to the ground plane is recommended

9.1.3 Package Drawings and Marking DFN10 3x3

Figure 21 – DFN10 – 3x3mm Package Drawing

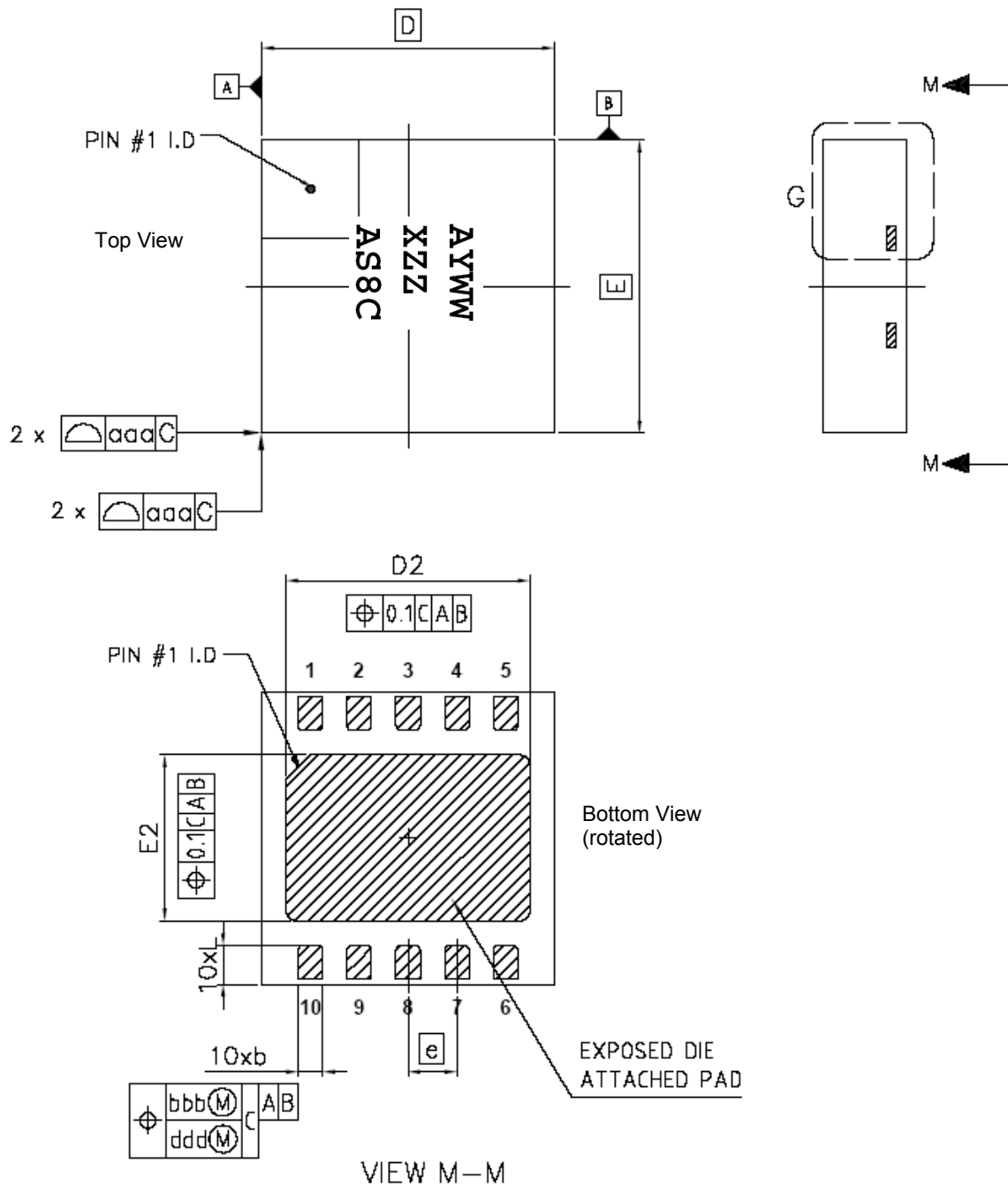

Marking:

- Line 1: AYWW
 A = Pb-Free Identifier
 Y = Year
 WW = Week
- Line 2: XZZ
 X = Plant Identifier
 ZZ = Letters of Free Choice
- Line 3: AS8C for AS3685C

Figure 22 – DFN10 – 3x3mm Detail Dimensions

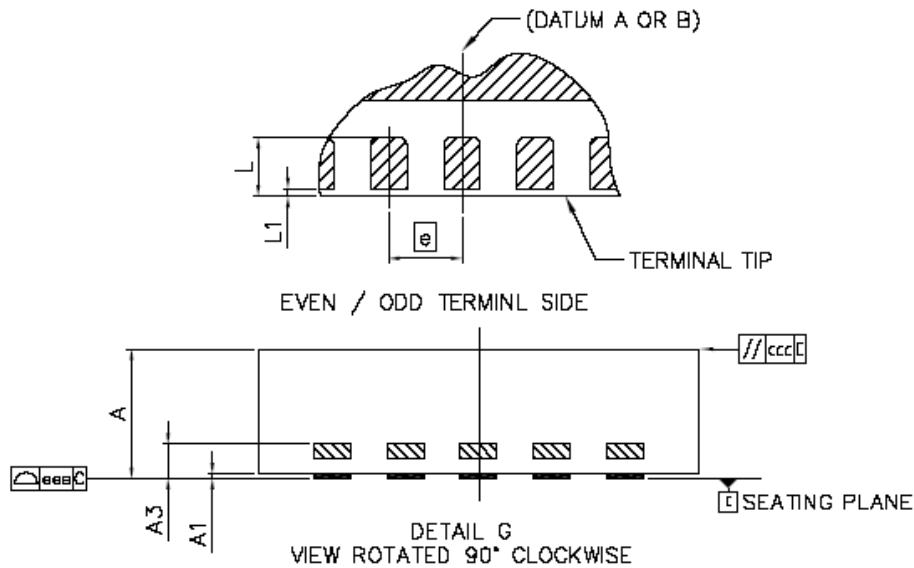

DIM	MIN	NOM	MAX	NOTES
A	0.80	0.85	0.90	1.0 DIMENSIONING & TOLERANCEING CONFIRM TO ASME Y14.5M-1994.
A1	0.00		0.05	
A3		0.203 REF		
b	0.20	0.25	0.30	
D		3.00 BSC		
E		3.00 BSC		2.0 ALL DIMENSIONS ARE IN MILLIMETERS. ANGLES ARE IN DEGREES.
D2	2.40	2.50	2.60	
E2	1.60	1.70	1.80	3.0 DIMENSION b APPLIES TO METALLIZED TERMINAL AND IS MEASURED BETWEEN 0.25mm AND 0.30mm FROM TERMINAL TIP. DIMENSION L1 REPRESENTS TERMINAL FULL BACK FROM PACKAGE EDGE UP TO 0.1mm IS ACCEPTABLE.
e		0.50 BSC		
L	0.35	0.40	0.45	4.0 COPLANARITY APPLIES TO THE EXPOSED HEAT SLUG AS WELL AS THE TERMINAL.
L1			0.10	
aaa		0.10		
bbb		0.10		
ccc		0.10		
ddd		0.05		5.0 RADIUS ON TERMINAL IS OPTIONAL.
eee		0.08		

9.2 WL-CSP 2x1.5mm (Wafer Level Chip Scale Package)

9.2.1 Pin Assignments WL-CSP 2x1.5mm

Figure 23 – WL-CSP 2x1.5mm Pin Assignments

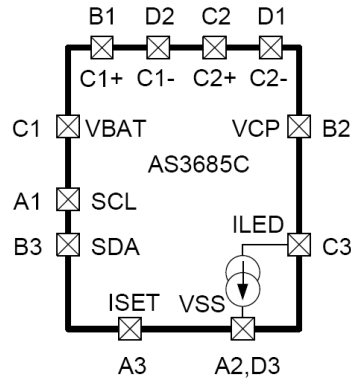

9.2.2 Pin Descriptions WL-CSP 2x1.5mm

Table 11 – Pin Type Descriptions WL-CSP 2x1.5mm

Pin Type	Description
AI/O	Analog Pin
DI	Digital Input
S	Supply Pin

Table 12 – Pin Descriptions WL-CSP 2x1.5mm

Pin Number	Pin Name	Type	Description
A1	SCL	DI	Digital Control Signal two wire interface clock input
A2	VSS	S	Ground Connection – a proper thermal connection to the ground plane is recommended
A3	ISET	AI/O	Current Generator input pin – connect current set resistor R _{ISET} between this pin and VSS (and optional R _{TXMASK})
B1	C1+	AI/O	Flying Capacitor 1 connection – connect 1 μF ceramic capacitor C _{FLY1} between C1- and C1+
B2	VCP	AI/O	Charge Pump Output voltage – connect flash LED anode to this pin and add C _{VCP} capacitor with 2.2 μF to VSS
B3	SDA	DI/O	Digital Input/Output Control two wire interface data signal
C1	VBAT	S	Battery Supply Voltage
C2	C2+	AI/O	Flying Capacitor 2 connection – connect 1 μF ceramic capacitor C _{FLY2} between C2- and C2+
C3	ILED	AI/O	Current Source input pin – connect flash LED cathode to this pin
D1	C2-	AI/O	Flying Capacitor 2 connection – connect 1 μF ceramic capacitor C _{FLY2} between C2- and C2+
D2	C1-	AI/O	Flying capacitor 1 connection – connect 1 μF ceramic capacitor C _{FLY1} between C1- and C1+
D3	VSS	S	Ground Connection – a proper thermal connection to the ground plane is recommended

9.2.3 Package Drawings and Marking WL-CSP 2x1.5mm

Figure 24 – WL-CSP 2x1.5mm Package Drawing

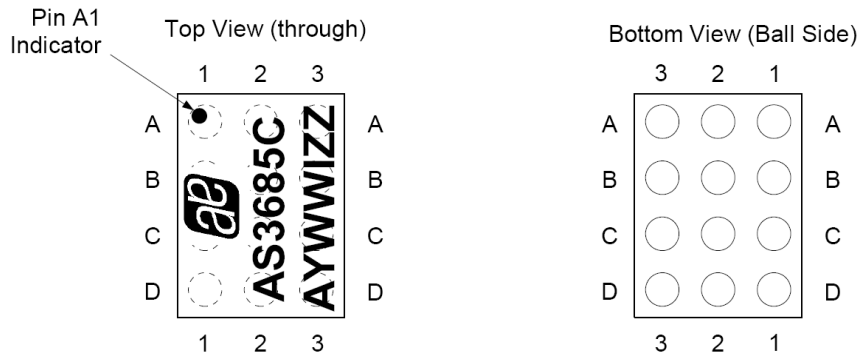

Marking:

- Line 1: austriamicrosystems logo
- Line 2: AS3685C
- Line 3: AYWWIZZ
 - A = Pb-Free Identifier
 - Y = Year
 - WW = Week
 - I = Plant Identifier
 - ZZ = Letters of Free Choice

Figure 25 – WL-CSP 2x1.5mm Detail Dimensions

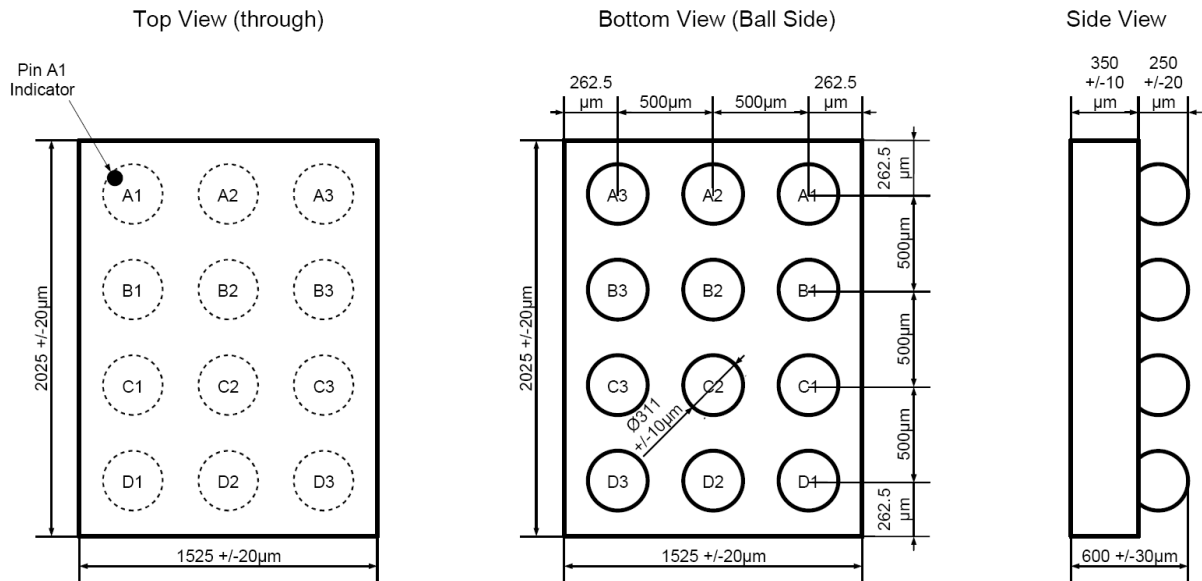

10 Ordering Information

Table 13 – Delivery Information

Part Number	Marking	Package Type	Delivery Form	Description
AS3685C-ZWLT	AS3685C	WL-CSP 2x1.5mm	Tape&Reel	AS3685C Interface Wafer Level Chip Scale Package, Size 2x1.5mm, 4x3 balls, 0.5mm pitch, RoHS compliant / Pb-free
AS3685C-ZDFT ¹	AS8C	DFN 10 3x3mm	Tape&Reel	AS3685C Interface DFN Package, 3x3mm, 10 pins, 0.4mm pitch, RoHS compliant / Pb-free

Description:

AS3685C-ZPPT

AS3685

C	...	AS3685C Interface Version
-		Two wire interface signal with STROBE
Z	...	Temperature range: Z = -30°C – 85°C
PP	...	Package: WL = Wafer Level Chip Scale Package DF = DFN10
T	...	Delivery Form: T = Tape&Reel

¹ Contact austriamicrosystems for availability.

Copyright

Copyright © 1997-2010, austriamicrosystems AG, Tobelbaderstrasse 30, 8141 Unterpremstaetten, Austria-Europe. Trademarks Registered ®. All rights reserved. The material herein may not be reproduced, adapted, merged, translated, stored, or used without the prior written consent of the copyright owner.

All products and companies mentioned are trademarks or registered trademarks of their respective companies.

Disclaimer

Devices sold by austriamicrosystems AG are covered by the warranty and patent indemnification provisions appearing in its Term of Sale. austriamicrosystems AG makes no warranty, express, statutory, implied, or by description regarding the information set forth herein or regarding the freedom of the described devices from patent infringement. austriamicrosystems AG reserves the right to change specifications and prices at any time and without notice. Therefore, prior to designing this product into a system, it is necessary to check with austriamicrosystems AG for current information. This product is intended for use in normal commercial applications. Applications requiring extended temperature range, unusual environmental requirements, or high reliability applications, such as military, medical life-support or life-sustaining equipment are specifically not recommended without additional processing by austriamicrosystems AG for each application. For shipments of less than 100 parts the manufacturing flow might show deviations from the standard production flow, such as test flow or test location.

The information furnished here by austriamicrosystems AG is believed to be correct and accurate. However, austriamicrosystems AG shall not be liable to recipient or any third party for any damages, including but not limited to personal injury, property damage, loss of profits, loss of use, interruption of business or indirect, special, incidental or consequential damages, of any kind, in connection with or arising out of the furnishing, performance or use of the technical data herein. No obligation or liability to recipient or any third party shall arise or flow out of austriamicrosystems AG rendering of technical or other services



Contact Information

Headquarters

austriamicrosystems AG
Tobelbaderstrasse 30
Schloss Premstätten
A-8141 Austria

Tel: +43 (0) 3136 500 0
Fax: +43 (0) 3136 525 01

For Sales Offices, Distributors and Representatives, please visit:
<http://www.austriamicrosystems.com/contact>