

AS3658

Power and Audio Management Unit for Portable Devices

Product Brief

1 General Description

The AS3658 is highly integrated power and audio management unit. It includes all the features from the AS3654 and adds on top an 16 bit Audio ADC, a second headphone amplifier, a microphone bias with amplifier, a RTC with alarm and time function, an unique ID block and three more LDOs.

2 Key Features

- System Control
 - Serial Control Interface
 - On/Off Control Module with Boot-ROM / GPIO
 - Reset Generation for system controller
 - Programmable Interrupt Controller and Watchdog
 - Low power off mode (9 μ A; 2.5V LDO on)
 - 88 bit unique ID or Boot fuse array
 - Reset with long ON-Keypress (5s, SW-Interruptable)
 - Touchscreen Interface (10 bit, interrupt)
- Supply Voltage Generation
 - 2 RF Programmable Low Noise LDOs (250mA)
(1 LDO can be a current controlled switch for hotplug (200mA +/-40%))
 - 1 RF Programmable Low Noise LDO (400mA)
 - 4 Programmable Dig. Low Power LDOs(200mA)
 - 2 General Purpose PWM DC/DC step up converter with three programmable current sinks (e.g. for white led); for current mode feedback is automatically selected (DCDC_CURR1,2,3)
 - 3 General Purpose high efficiency DC/DC step down converter (DCDC 1 support DVM)
 - 1 Low noise charge pump with 5V output voltage
 - 1 Ultra Low Power 2.5V LDO (always on)
- Current sinks
 - 4 programmable(8-bit) from 0.15mA to 38.25mA (+/-5%) optional useable as GPIOs
 - 3 programmable high voltage (15V) (8-bit) from 0.15mA to 38.25mA (+/-5%)
 - internal PWM generator (extended time range)
(can control DCDC_CURR1,2,3)
- 10-bit 40 μ s Successive Approximation ADC
 - Two external Inputs (ADC_IN1, ADC_IN2)
- Battery Management
 - Full featured chemistry independent step down charger with Gas Gauge and Current limitation
 - High Current (1.0A) Linear Charger with external pass transistor (no SD charger)
 - 0.1 Ω Battery switch for start-up and trickle charge
 - Integrated USB charger up to 880mA (can be used as wall adapter charger); current accuracy 440-500mA for USB specification, in-circuit trimmable (+/-1.2% trimsteps)
 - Autonomous Battery Temperature Supervision (0 $^{\circ}$ C-45 $^{\circ}$ C or 0 $^{\circ}$ C- 50 $^{\circ}$ C) for 10k and 100k NTC
 - Charging Timeout (1h-8h in 30min steps)
 - Charging in Standby mode
 - Completely Autonomous (no SW)
- Power Management Features
 - Wide Battery Supply Range 3.0...5.5V
 - High Accuracy Reference (\pm 1%)
 - Thermal and Current Protection (int. sensor)
 - Standby Mode exit by interrupt
e.g. Onkey/RTC
- Audio
 - 94dB Audio DAC, 16-48kHz sampling rate
 - Two Digital Audio Inputs (2 x I2S interface)
 - 2.9V low Noise LDO for Audio DAC
 - Two Headphone Amplifier Output with GND separation
 - Two I2S Inputs and one I2S Output
 - I2S master mode with programmable sample rate (controlled by internal PLL)
 - GND Buffer for Headphone Amplifier
 - Line/ Headphone outputs with GND separation
 - Audio ADC, 82dB SNR with 16ksps
 - Mono Microphone Supply and Amplifier
 - 5 Band Adjustable Audio Equalizer (+/-12dB in 3dB gain steps)
 - SPDIF Output
 - Audio Mixer and Gain Stages
 - PCM Interface
- Real Time Clock (RTC)
 - Alarm and Time function
 - Repeated Wakeup (every sec. or minute)
 - 32kHz output
 - Backup Battery Charger and Switchover
- Programmable System clock
 - 1.6 MHz to 2.3 MHz with 100 kHz steps
- Package
 - BGA124 8x8mm, 0.5mm pitch (can be assembled without microvia boards)

3 Application

- PDA, PMP, GPS-Navigation System
- 1 Cell Li+ or 3 Cell NiMH powered devices

Figure 1 – Blockdiagram AS3658

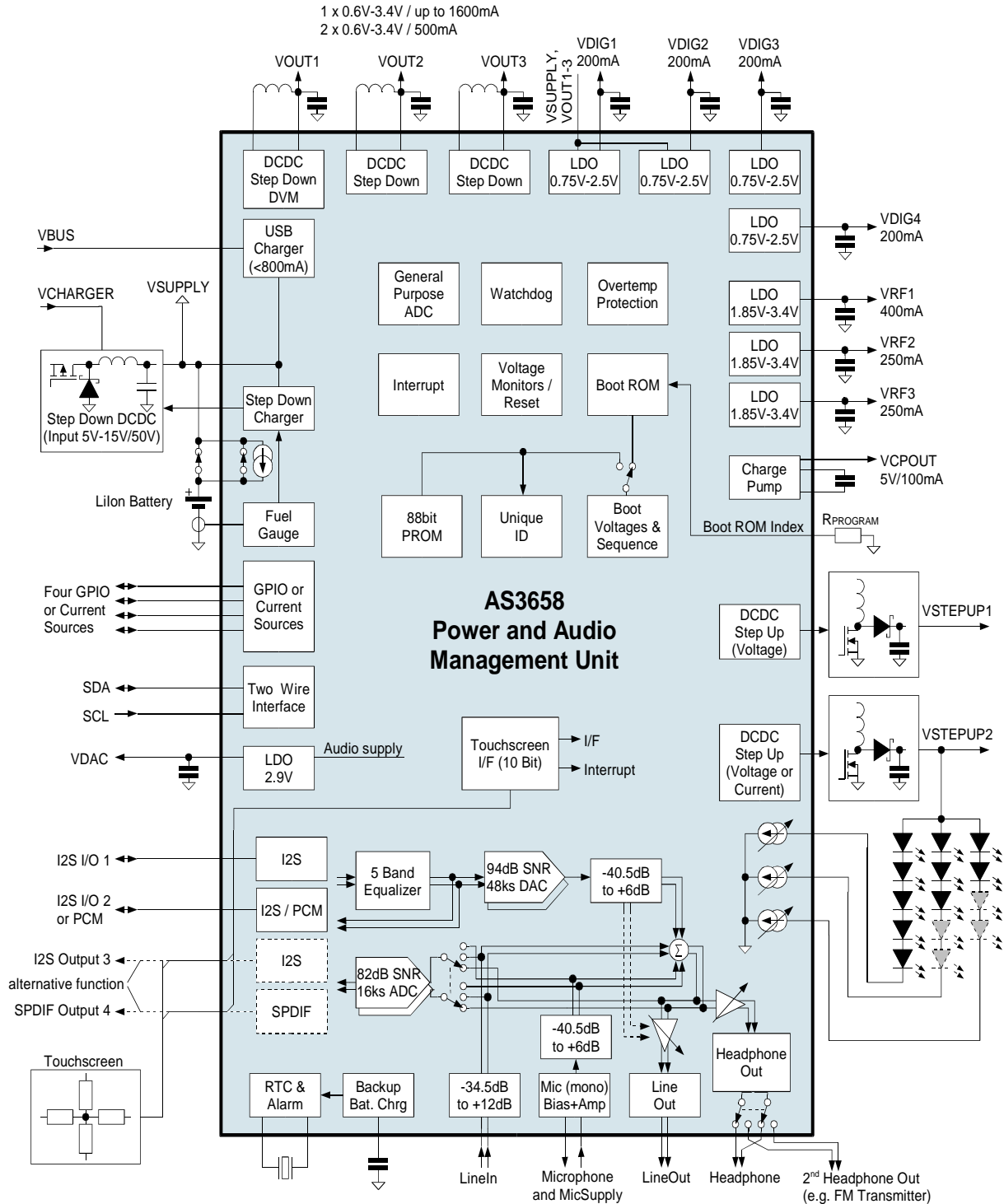

Copyright

Copyright © 1997-2007, austriamicrosystems AG, Schloss Premstaetten, 8141 Unterpremstaetten, Austria-Europe. Trademarks Registered ®. All rights reserved. The material herein may not be reproduced, adapted, merged, translated, stored, or used without the prior written consent of the copyright owner.

All products and companies mentioned are trademarks or registered trademarks of their respective companies.

Disclaimer

Devices sold by austriamicrosystems AG are covered by the warranty and patent indemnification provisions appearing in its Term of Sale. austriamicrosystems AG makes no warranty, express, statutory, implied, or by description regarding the information set forth herein or regarding the freedom of the described devices from patent infringement. Austriamicrosystems AG reserves the right to change specifications and prices at any time and without notice. Therefore, prior to designing this product into a system, it is necessary to check with austriamicrosystems AG for current information.

This product is intended for use in normal commercial applications. Applications requiring extended temperature range, unusual environmental requirements, or high reliability applications, such as military, medical life-support or lifesustaining equipment are specifically not recommended without additional processing by austriamicrosystems AG for each application. For shipments of less than 100 parts the manufacturing flow might show deviations from the standard production flow, such as test flow or test location.

The information furnished here by austriamicrosystems AG is believed to be correct and accurate. However, austriamicrosystems AG shall not be liable to recipient or any third party for any damages, including but not limited to personal injury, property damage, loss of profits, loss of use, interruption of business or indirect, special, incidental or consequential damages, of any kind, in connection with or arising out of the furnishing, performance or use of the technical data herein. No obligation or liability to recipient or any third party shall arise or flow out of austriamicrosystems AG rendering of technical or other services.



Contact Information

Headquarters

austriamicrosystems AG
A-8141 Schloss Premstätten, Austria
T. +43 (0) 3136 500 0
F. +43 (0) 3136 5692

For Sales Offices, Distributors and Representatives, please visit:
<http://www.austriamicrosystems.com/contact>