

AS3400 AS3410 AS3430 Preliminary Data Sheet, Strictly Confidential

Low Power Ambient Noise-Cancelling Speaker Driver

1 General Description

The AS3400/10/30 are speaker driver with Ambient Noise Cancelling function for handsets, headphones or ear pieces. It is intended to improve quality of e.g. music listening, a phone conversation etc. by reducing background ambient noise.

The fully analog implementation allows the lowest power consumption, lowest system BOM cost and most natural received voice enhancement otherwise difficult to achieve with DSP implementations. The device is designed to be easily applied to existing architectures.

An internal OTP-ROM can be optionally used to store the microphones gain calibration settings.

The AS3400/10/30 can be used in different configurations for best trade-off of noise cancellation, required filtering functions and mechanical designs.

The simpler feed-forward topology is used to effectively reduce low frequency background noise. The feed-back topology with either 1 or 2 filtering stages can be used to reduce noise for a larger frequency range, and to even implement transfer functions like speaker equalization, Baxandall equalization, high/low shelving filter and to set a predefined loop bandwidth.

The filter loop is optimized by the user for specific handset electrical and mechanical designs by dimensioning simple R, C components.

Most handset implementations will make use of a single noise detecting microphone. Two microphones could be used to allow for increased flexibility of their location in the handset mechanical design. Using the bridged mode allows to even drive high impedance headsets.

2 Key Features

Microphone Input

- 128 gain steps @0.375dB and MUTE with AGC
- differential, low noise microphone amplifier
- single ended or differential mode
- improved supply for electret microphone
- MIC gain OTP programmable

High Efficiency Headphone Amplifier

- 2x34mW, 0.1% THD @ 16Ω, 1.5V supply, 100dB SNR
- bridged mode for e.g. 300Ω loads
- click and pop less start-up and mode switching

Line Input

- volume control via serial interface or volume pin
- 64 steps @ 0.75dB and MUTE, pop-free gain setting
- single ended stereo or mono differential mode

ANC processing

- feed-forward cancellation
- feed-back cancellation with filter loop transfer function definable via simple RC components
- simple in production SW calibration
- 12-30dB noise reduction (headset dependent)
- 10-2000Hz wide frequency active noise attenuation (headset dependent)

Monitor Function

- for assisted hearing, i.e. to monitor announcements
- fixed (OTP prog.) ambient sound amplification to compensate headphone passive attenuation
- volume controlled ambient sound amplification mixed with fixed (OTP prog.) attenuation of LineIn

Incremental Functions

- ANC with or without music on the receiving path
- improved dynamic range playback
- OTP ROM for automatic trimming during production (4 times programmable)

Performance Parameter

- 5/3.8mA @ 1.5V stereo/mono ANC; <1uA quiescent
- extended PSRR for 217Hz

Interfaces

- 2 wire serial control mode & volume inputs
- calibration via Line-In or 2-wire serial interface
- single cell or fixed 1.0-1.8V supply with internal CP

Package

- AS3400, AS3410 QFN24 [4x4mm] 0.5mm pitch
- AS3430 QFN32 [5.x5mm] 0.5mm pitch

3 Applications

Ear pieces, Headsets, Hands-Free Kits, Mobile Phones, Voice Communicating Devices

Figure 1. AS3410 Feed Forward ANC Block Diagram

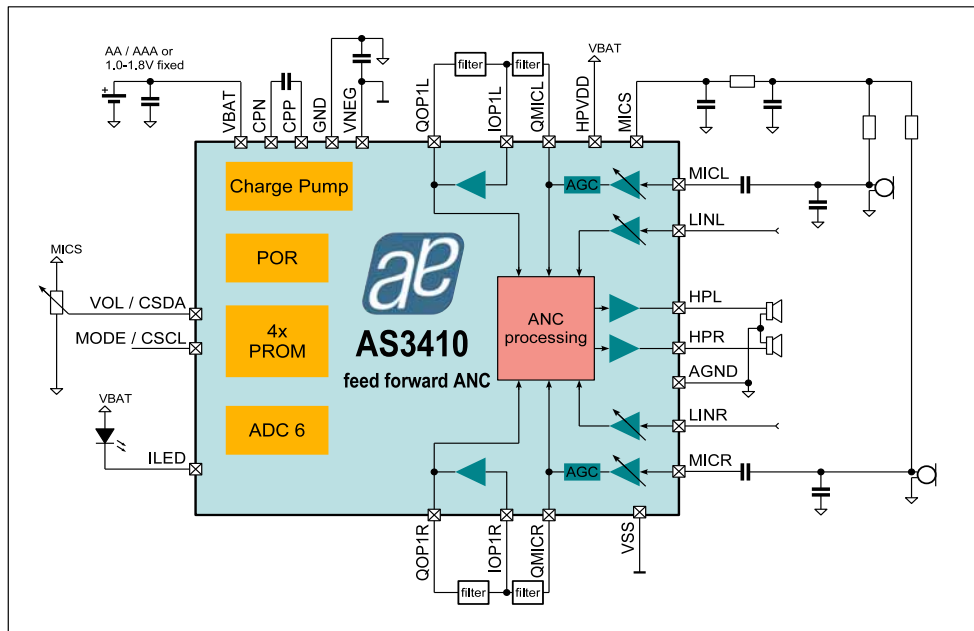
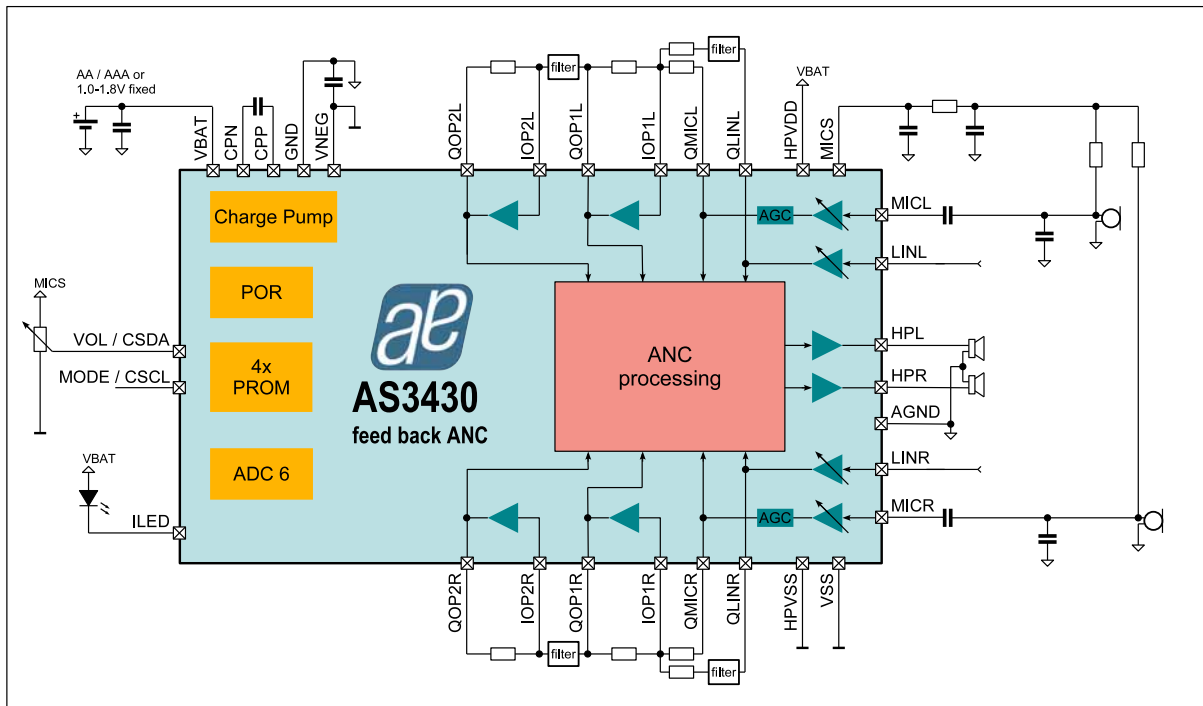

Figure 2. AS3430 Feed-Back Block Diagram



Contents

| | |
|--|-----------|
| 1 General Description | 1 |
| 2 Key Features | 1 |
| 3 Applications | 1 |
| 4 Pinout | 5 |
| 4.1 Pin Assignment | 5 |
| 4.2 Pin Description | 6 |
| 5 Absolute Maximum Ratings | 7 |
| 6 Electrical Characteristics | 8 |
| 7 Typical Operating Characteristics | 9 |
| 8 Detailed Description | 12 |
| 8.1 Audio Line Input | 12 |
| 8.2 Microphone Input | 13 |
| 8.3 Headphone Output | 15 |
| 8.4 Operational Amplifier | 16 |
| 8.5 SYSTEM | 17 |
| 8.6 VNEG Charge Pump | 19 |
| 8.7 OTP Memory & Internal Registers | 19 |
| 8.8 2-Wire-Serial Control Interface | 22 |
| 9 Register Description | 25 |
| 10 Application Information | 39 |
| 11 Package Drawings and Markings | 43 |
| 12 Ordering Information | 47 |

Revision History

Table 1. Revision History

| Revision | Date | Owner | Description |
|----------|-----------|-------|---|
| 0.1 | 19.1.2010 | pkm | initial release |
| 0.2 | 29.1.2010 | pkm | updated block diagrams and application schematics |
| | | | |
| | | | |

4 Pinout

4.1 Pin Assignment

Please observe that pin assignment may change in preliminary data sheets.

Figure 3. Pin Assignments (Top View)

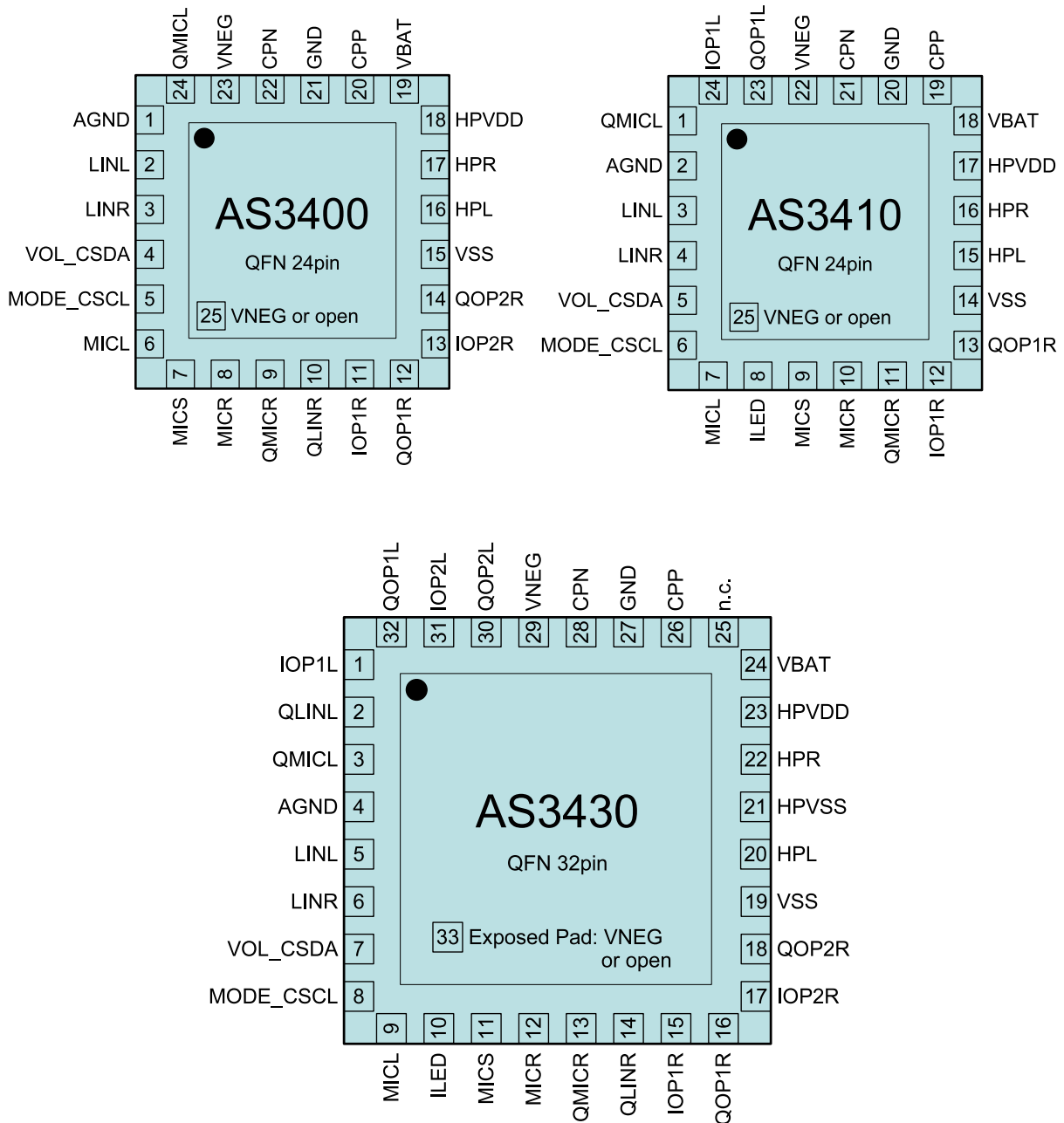

4.2 Pin Description

Please observe that pin description may change in preliminary data sheets.

Table 2. Pin Description for AS3400 AS3410 AS3430

| AS3400 | AS3410 | AS3430 | Pin Name | Type | Description |
|--------|--------|--------|-----------|------------------|--|
| - | 24 | 1 | IOP1L | ANA IN | Filter OpAmp1 Input Left Channel |
| - | - | 2 | QLINL | ANA OUT | Line In GainStage Output Left Channel |
| 24 | 1 | 3 | QMICL | ANA OUT | MIC GainStage Output Right Channel |
| 1 | 2 | 4 | AGND | ANA IN | Analog Reference |
| 2 | 3 | 5 | LINL | ANA IN DIG IN | Line In Left Channel During Appl Trim Mode Write – CSDA During Appl Trim Mode Burn - VNEG |
| 3 | 4 | 6 | LINR | ANA IN DIG IO | LineIn Right Channel During Appl Trim Mode Write – CSCL During Appl Trim Mode Burn - Clock |
| 4 | 5 | 7 | VOL_CSDA | MIXED IO | Serial Interface Data ADC Input for volume regulation |
| 5 | 6 | 8 | MODE_CSCL | DIG IN | Mode Pin (PowerUp/Dn, Monitor) Serial Interface Clock |
| 6 | 7 | 9 | MICL | ANA IN | Microphone In Left Channel |
| - | 8 | 10 | ILED | ANA OUT | Current Output for on-indication LED |
| 7 | 9 | 11 | MICS | ANA OUT | Microphone Supply |
| 8 | 10 | 12 | MICR | ANA IN | Microphone Input Right Channel |
| 9 | 11 | 13 | QMICR | ANA OUT | MIC GainStage Output Right Channel |
| 10 | - | 14 | QLINR | ANA OUT | Line In GainStage Output Right Channel |
| 11 | 12 | 15 | IOP1R | ANA IN | FilterOpAmp1 Input Right Channel |
| 12 | 13 | 16 | QOP1R | ANA IN | Filter OpAmp1 Output Right Channel |
| 13 | - | 17 | IOP2R | ANA IN | Filter OpAmp2 Input Right Channel |
| 14 | - | 18 | QOP2R | ANA OUT | Filter OpAmp2 Output Right Channel |
| 15 | 14 | 19 | VSS | SUP IN | Core and Periphery Circuit VSS Supply |
| 16 | 15 | 20 | HPL | ANA OUT | Headphone Output Left Channel |
| - | - | 21 | HPVSS | SUP IN | Headphone VSS Supply |
| 17 | 16 | 22 | HPR | ANA OUT | Headphone Output Right Channel |
| 18 | 17 | 23 | HPVDD | SUP IN | Headphone VDD Supply |
| 19 | 18 | 24 | VBAT | SUP IN | VNEG ChargePump Positive Supply |
| - | - | 25 | n.c. | - | |
| 20 | 19 | 26 | CPP | ANA OUT | VNEG ChargePump Flying Capacitor Positive Terminal |
| 21 | 20 | 27 | GND | GND | VNEG ChargePump Negative Supply |
| 22 | 21 | 28 | CPN | ANA OUT | VNEG ChargePump Flying Capacitor Negative Terminal |
| 23 | 22 | 29 | VNEG | SUP IO | VNEG ChargePump Output |
| - | - | 30 | QOP2L | ANA OUT | Filter OpAmp2 Output Left Channel |
| - | - | 31 | IOP2L | ANA IN | Filter OpAmp2 Input Left Channel |
| - | 23 | 32 | QOP1L | ANA OUT | Filter OpAmp1 Output Right Channel |
| 25 | 25 | 33 | | | Exposed Pad: connect to VNEG or leave it unconnected |

5 Absolute Maximum Ratings

Stresses beyond those listed in [Table 3](#) may cause permanent damage to the device. These are stress ratings only, and functional operation of the device at these or any other conditions beyond those indicated in [Electrical Characteristics on page 8](#) is not implied. Exposure to absolute maximum rating conditions for extended periods may affect device reliability. The device should be operated under recommended operating conditions.

Table 3. Absolute Maximum Ratings

| Parameter | Min | Max | Units | Comments |
|---|--------------|------------------|-------|--|
| Reference Ground | | | | Defined as in GND |
| Supply terminals | -0.5 | 2.0 | V | Applicable for pin VBAT, HPVDD |
| Ground terminals | -0.5 | 0.5 | V | Applicable for pins AGND |
| Negative terminals | -2.0 | 0.5 | V | Applicable for pins VNEG, VSS, HPVSS |
| Voltage difference at VSS terminals | -0.5 | 0.5 | V | Applicable for pins VSS, HPVSS |
| Pins with protection to VBAT | VNEG -0.5 | 5.0 VBAT+0.5 | V | Applicable for pins CPP, CPN |
| Pins with protection to HPVDD | VSS -0.5 | 5.0 HPVDD+0.5 | V | Applicable for pins LINL/R, MICL/R, ILED, HPR, HPL, QMICL/R, QLINL/R, IOPx, QOPx |
| other pins | VSS -0.5 | 5 | | applicable for pins MICS, VOL_CSDA, MODE_CSCL |
| Input Current (latch-up immunity) | -100 | 100 | mA | Norm: JEDEC 17 |
| Continuous Power Dissipation (T_A = +70°C) | | | | |
| Continuous Power Dissipation | - | 200 | mW | P _T ¹ for QFN16/24/32 package |
| Electrostatic Discharge | | | | |
| Electrostatic Discharge HBM | | +/-2 | kV | Norm: JEDEC JESD22-A114C |
| Temperature Ranges and Storage Conditions | | | | |
| Operating Temperature Range | -20 | +85 | °C | |
| Junction Temperature | | +110 | °C | |
| Storage Temperature Range | -55 | +125 | °C | |
| Humidity non-condensing | 5 | 85 | % | |
| Bump Temperature (soldering) | | | | |
| Package Body Temperature | | 260 | °C | Norm IPC/JEDEC J-STD-020C, reflects moisture sensitivity level only |
| Solder Profile | 235 | 245 | °C | peak temperature |
| | 30 | 45 | s | well time above 217 °C |
| Moisture Sensitive Level | | 3 | 1 | Represents a max. floor live time of 168h |

1. Depending on actual PCB layout and PCB used

6 Electrical Characteristics

VBAT = 1.0V to 1.8V, T_A = -20°C to +85°C. Typical values are at VBAT = 1.5V, T_A = +25°C, unless otherwise specified.

Table 4. Electrical Characteristics

| Symbol | Parameter | Condition | Min | Max | Unit |
|------------------------|---|---|----------------------|----------------------|------|
| Supply Voltages | | | | | |
| GND | Reference Ground | | 0 | 0 | V |
| VBAT, HPVDD | Battery Supply Voltage | | 1.0 | 1.8 | V |
| VNEG | ChargePump Voltage | | -1.8 | -0.7 | V |
| VSS | Analog neg. Supply Voltages HPVSS, VSS, VNEG | | -1.8 | -0.7 | V |
| V _{DELTA-} | Difference of Ground Supplies GND, AGND | To achieve good performance, the negative supply terminals should be connected to low impedance ground plane. | -0.1 | 0.1 | V |
| V _{DELTA--} | Difference of Negative Supplies VSS, VNEG, HPVSS | Charge pump output or external supply | -0.1 | 0.1 | V |
| V _{DELTA+} | Difference of Positive Supplies | VBAT-HPVDD | -0.25 | 0.25 | V |
| other pins | | | | | |
| V _{MICS} | Microphone Supply Voltage | MICS | 0 | 3.6 | V |
| V _{HPVDD} | pins with diode to HPVDD | MICL/R, ILED, HPR, HPL, QMICL/R, QLINL/R, IOPx, QOPx | VSS | 3.6 | V |
| V _{VBAT} | pins with diode to VBAT | CPP, CPN | VNEG | VBAT | V |
| V _{CONTROL} | Control Pins | MODE_CSCL, VOL_CSDA | VSS | 3.7 | V |
| V _{TRIM} | Line Input & Application Trim Pins | LINL, LINR | VNEG -0.5 or -1.8 | HPVDD +0.5 or 1.8 | V |

| Symbol | Parameter | Condition | Min | Typ | Max | Unit |
|-------------------|-----------------|-------------|-----|-----|-----|------|
| I _{leak} | leakage current | VBAT < 0.8V | | | 20 | μA |
| | | VBAT < 0.6V | | | 10 | μA |

Block Power Requirements @ 1.5V VBAT

| Symbol | Parameter | Condition | Min | Typ | Max | Unit |
|-------------------|---------------------------|--|-----|------|-----|------|
| I _{SYS} | Reference supply current | bias generation, oscillator, ILED current sink, ADC6 | | 0.25 | | mA |
| I _{LIN} | LineIn gain stage current | no signal, stereo | | 0.64 | | mA |
| I _{MIC} | Mic gain stage current | no signal, stereo | | 2.10 | | mA |
| I _{HP} | Headphone stage current | no signal | | 1.70 | | mA |
| I _{VNEG} | VNEG charge pump current | no load | | 0.25 | | mA |
| I _{MICS} | MICS charge pump current | no load | | 0.06 | | mA |
| I _{MIN} | minimal supply current | sum of all above blocks | | 5.00 | | mA |
| I _{OP1} | OP1 supply current | no load | | 0.64 | | mA |
| I _{OP2} | OP2 supply current | no load | | 0.64 | | mA |
| I _{ILED} | ILED current sink current | 100% duty cycle | | 2.50 | | mA |
| I _{MICB} | Microphone bias current | 200uA per microphone via charge pump | | 1.30 | | mA |

7 Typical Operating Characteristics

V_{BAT} = +1.5V, T_A = +25°C, unless otherwise specified.

Figure 4. LIN to HPH: THD+N versus Output Power

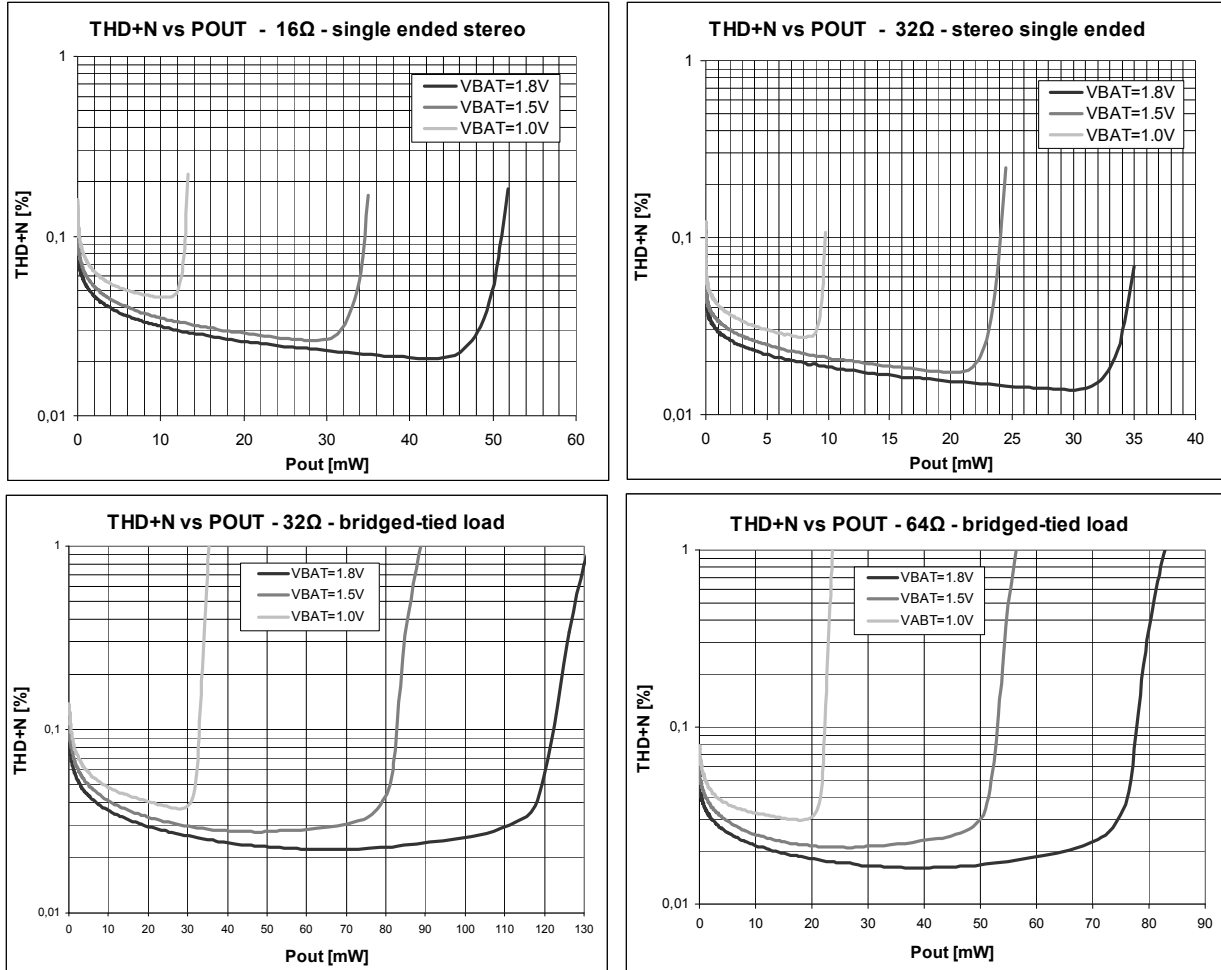

Figure 5. VNEG Charge Pump

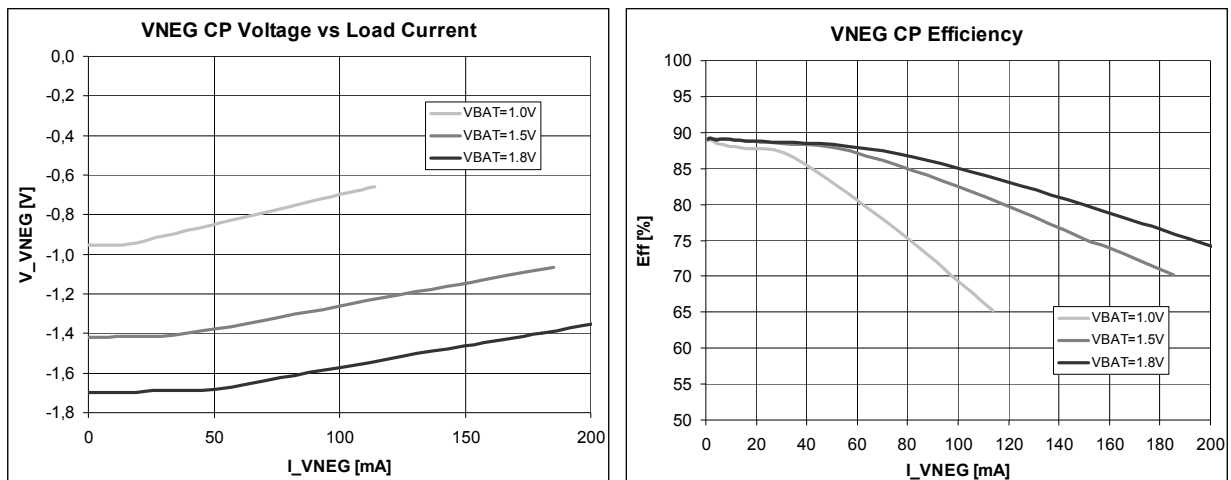

Figure 6. Microphone Supply Generation

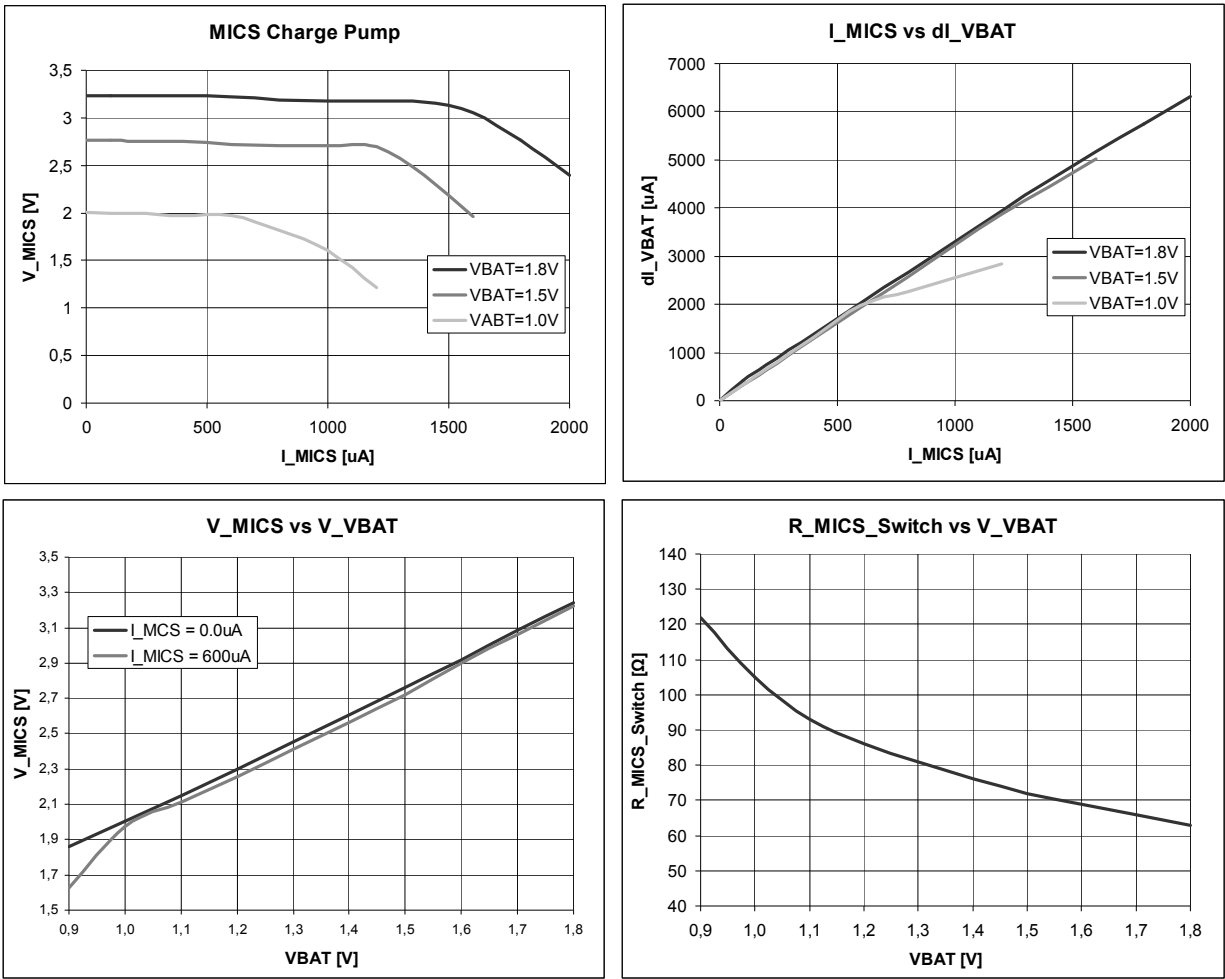

Figure 7. ILED Current Sink (100% PWM setting)

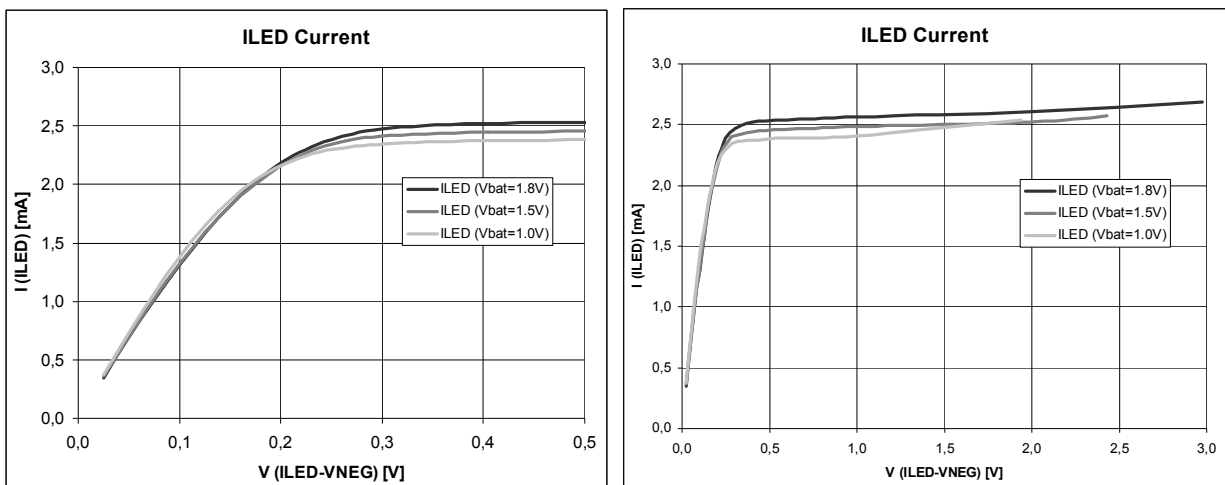

Figure 8. THD vs. frequency @ 1.5V, 16Ω, 25mW

Audio Precision

03/12/09 22:48:36

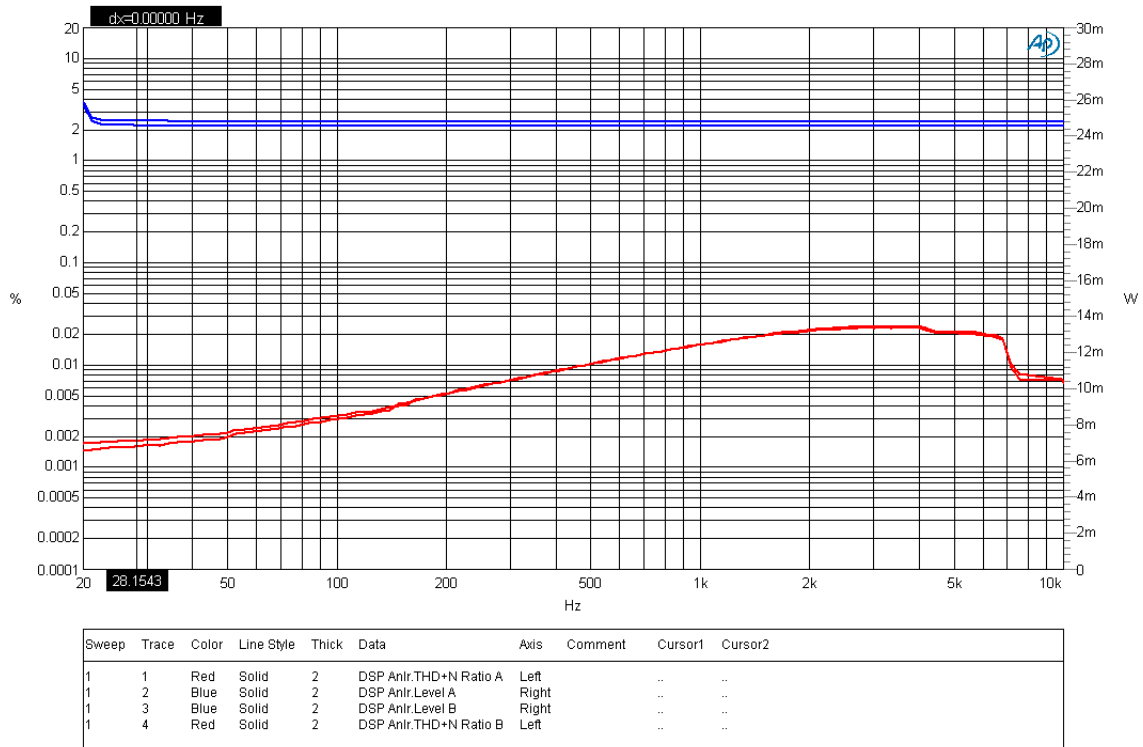
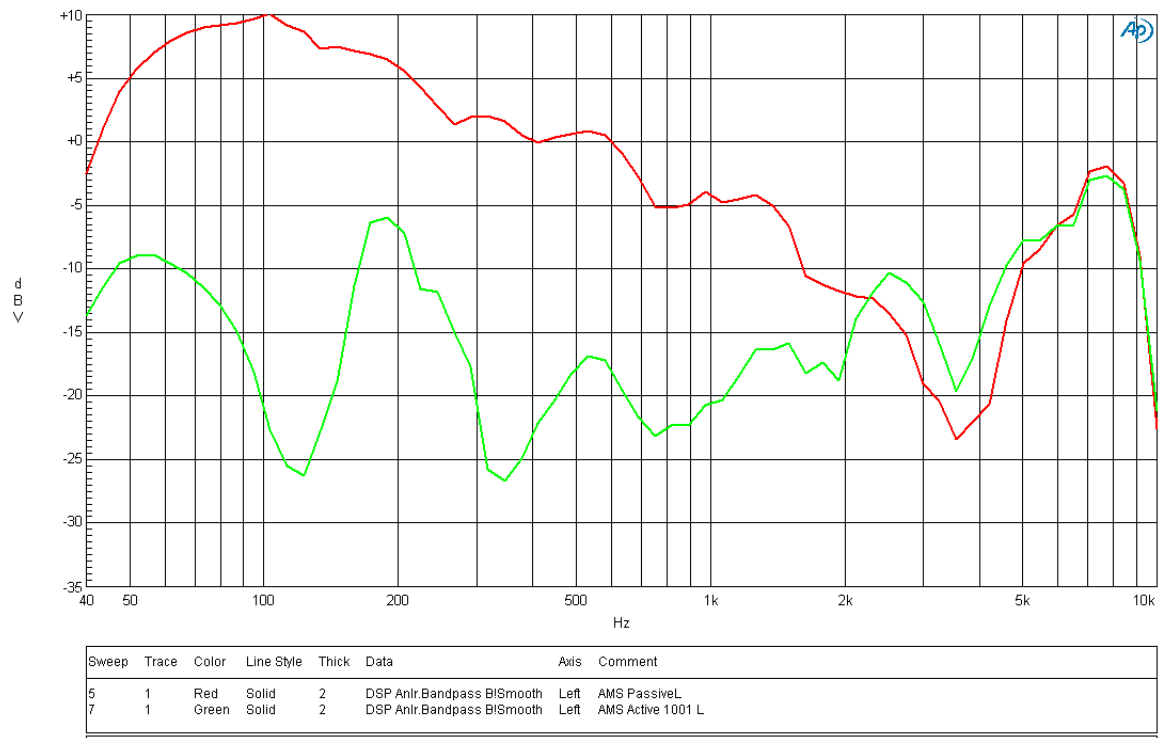

Figure 9. Typical Performance Data, FF configuration

Audio Precision

02/24/09 18:14:27



8 Detailed Description

8.1 Audio Line Input

8.1.1 General

The chip features one line input. The blocks can work in mono differential or in stereo single ended mode.

In addition to the 12.5-25kΩ input impedance, LinIn has a termination resistor of 10kΩ which is also effective during MUTE to charge eventually given input capacitors.

8.1.2 Gain Stage

The Line In gain stage is designed to have 63 gain steps of 0.75dB with a max gain of 0dB plus MUTE.

In default, the gain will be ramped up from MUTE to 0dB during startup. There is a possibility to make the playback volume user controlled by the VOL pin with an ADC converted VOL voltage or UP/DN buttons.

In monitor mode the gain stage can be set to an fixed default attenuation level for reducing the loudness of the music.

Figure 10. Line Inputs

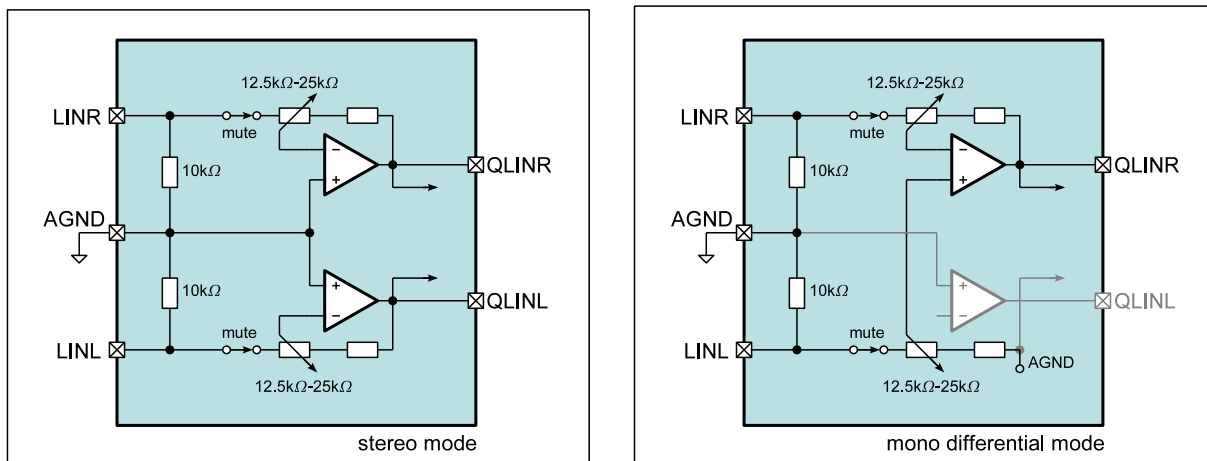

8.1.3 Parameter

V_{BAT}=1.5V, T_A= 25°C, unless otherwise mentioned

Table 5. Line Input Parameter

| Symbol | Parameter | Condition | Min | Typ | Max | Unit | |
|----------------------|---------------------------|---------------------------|---------------------------------|--------------------------|------------------|-------------------|----|
| V _{LIN} | Input Signal Level | | | 0.6* V _{BAT} | V _{BAT} | V _{PEAK} | |
| R _{LIN} | Input Impedance | 0dB gain (12.5k // 10k) | | 5.6 | | kΩ | |
| | | -46.5dB gain (25k // 10k) | | 7.2 | | kΩ | |
| | | MUTE | | 10 | | kΩ | |
| ΔR _{LIN} | Input Impedance Tolerance | | | ±30 | | % | |
| C _{LIN} | Input Capacitance | | | 5 | | pF | |
| A _{LIN} | Programmable Gain | | -46.5 | | +0 | dB | |
| | | Gain Steps | discrete logarithmic gain steps | | 0.75 | | dB |
| | | Gain Step Accuracy | | | 0.5 | | dB |
| A _{LINMUTE} | Mute Attenuation | | | 100 | | dB | |

Table 5. Line Input Parameter (Continued)

| Symbol | Parameter | Condition | Min | Typ | Max | Unit |
|-----------------|--------------------------|------------------------------|-----|-----------------|-----|------------|
| Δ_{ALIN} | Gain Ramp Rate | PotiMode, Tinit=100ms | | 20 | | ms/step |
| | | ButtonMode, Tinit=400ms | | 80 | | |
| | | MonitorMode | | 8 | | |
| V_{ATTACK} | Limiter Activation Level | HPL/R start of neg. clipping | | | | V_{PEAK} |
| V_{DECAY} | Limiter Release Level | HPL/R | | $V_{NEG} + 0.3$ | | V_{PEAK} |
| t_{ATTACK} | Limiter Attack Time | | | 4 | | μs |
| t_{DECAY} | Limiter Decay Time | | | 8 | | ms |

8.2 Microphone Input

8.2.1 General

The AFE offers two microphone inputs and one low noise microphone voltage supply (microphone bias). The inputs can be switched to single ended or differential mode.

Figure 11. Microphone Input

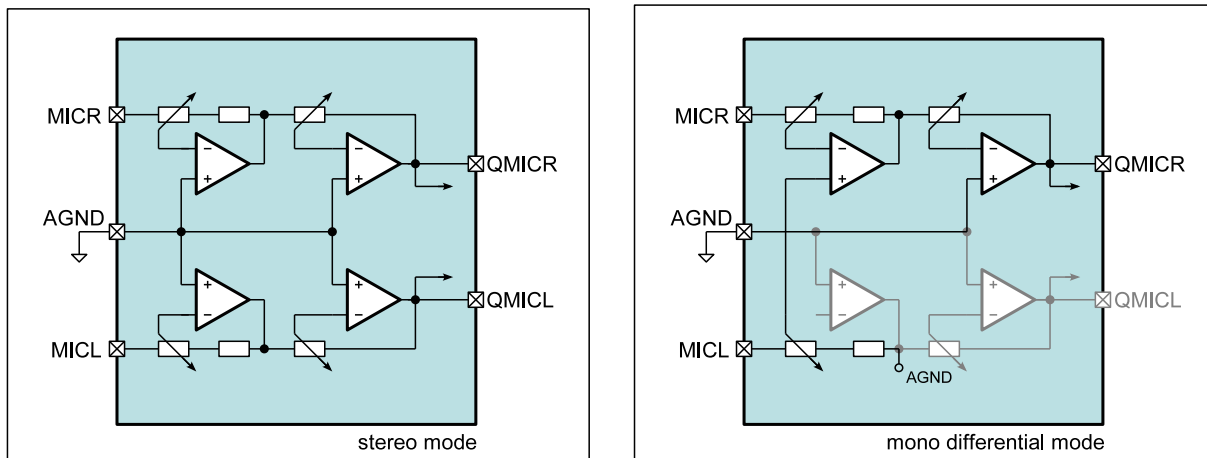

8.2.2 Gain Stage & Limiter

The Mic GainStage has programmable Gain within -6dB...+41.625dB in 128 steps of 0.375dB.

As soft-start function is implemented for an automatic gain ramping implemented with steps of 4ms to fade in the audio at the end of the start-up sequence.

A limiter automatically attenuates high input signals. The AGC has 127 steps with 0.375dB with a dynamic range of the full gain stage.

In monitor mode the gain stage can be set to an fixed (normally higher) gain level or be controlled by the VOL pin.

8.2.3 Supply

The MICS charge pump is providing a proper microphone supply voltage for the AAA supply. Since AAA batteries are operating down to 1.0V, the direct battery voltage cannot be used for mic-supply. There are 2 modes.

The first mode SWITCH-MODE for 1.8V supply is to have just a switch from VBAT to MICS. With this switch, the microphone current is switched off in idle mode.

The second mode CHAREGPUMP_MODE for AAA batteries is the real charge pump mode, in this mode a positive voltage is generated of about 2* VBAT.

It is also possible to switch off the microphone supply if not needed (e.g. playback without ANC)

8.2.4 Parameter

V_{BAT}=1.5V, T_A= 25°C unless otherwise mentioned

Table 6. Microphone Input Parameter

| Symbol | Parameter | Condition | Min | Typ | Max | Unit |
|------------------------|--------------------------------|---|-----|-------------------------------|-------|-----------------|
| V _{MICIN0} | Input Signal Level | A _{MIC} = 30dB | | 20 | | mV _P |
| V _{MICIN1} | | A _{MIC} = 36dB | | 10 | | mV _P |
| V _{MICIN2} | | A _{MIC} = 42dB | | 5 | | mV _P |
| R _{MICIN} | Input Impedance | MICP to AGND | | 7.5 | | kΩ |
| Δ _{MICIN} | Input Impedance Tolerance | | | -7 +33 | | % |
| C _{MICIN} | Input Capacitance | | | 5 | | pF |
| A _{MIC} | Programmable Gain | | -6 | | +41.6 | dB |
| | Gain Steps | discrete logarithmic gain steps | | 0.375 | | dB |
| | Gain Step Precision | | | 0.15 | | dB |
| Δ _{MIC} | Gain Ramp Rate | T _{init} =64ms | | 4 | | ms/ step |
| V _{ATTACK} | Limiter Activation Level | V _{PEAK} related to V _{BAT} or V _{NEG} | | 0.67 | | 1 |
| V _{DECAY} | Limiter Release Level | | | 0.4 | | 1 |
| A _{MICLIMIT} | Limiter Gain Overdrive | 127 @ 0.375dB | | 41.625 | | dB |
| t _{ATTACK} | Limiter Attack Time | | | 5 | | μs/ step |
| t _{DECAY-DEB} | Limiter Decay Debouncing Time | | | 64 | | ms |
| t _{DECAY} | Limiter Decay Time | | | 4 | | ms/ step |
| | | | | | | |
| V _{MICS} | Microphone Supply Voltage | | | V _{BAT} *2- 240mV | | V |
| I _{MICSMIN} | Min. Microphone Supply Current | V _{BAT} =+1.0V V _{NEG} =-0.7V MICS=+1.75V | | 650 | | μA |
| R _{OUT_CP} | CP Output Resistance | | | 1300 | | Ω |

8.3 Headphone Output

8.3.1 General

The headphone output is a true ground output using VNEG as negative supply, designed to provide the audio signal with $2 \times 12 \text{mW}$ @ 16Ω – 64Ω , which are typical values for headphones. It is also capable to operate in bridged mode for higher impedance (e.g. 300Ω) headphone. In this mode the left output is carrying the inverted signal of the right output.

Figure 12. Headphone Output

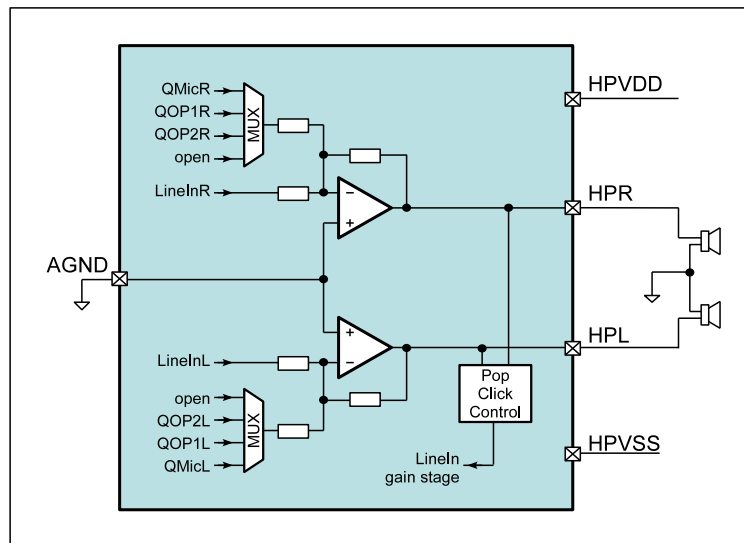

8.3.2 Input Multiplexer

The signal from the line-input gain stage gets summed at the input of the headphone stage with the microphone gain stage output, the first filter opamp output or the second filter opamp output. The microphone gain stage output is used per default. It is also possible to playback without ANC by only using the line-input gain stage with no other signal on the multiplexer.

For the monitor mode the setting of this input multiplexer can be changed to an other source, normally to the microphone.

8.3.3 No-Pop Function

The No-Pop startup of the headphone stage takes 60ms to 120ms dependent on the supply voltage.

8.3.4 No-Clip Function

The headphone output stage gets monitored by comparator stages which detect if the output signal starts to clip.

This signal is used to reduce the LineIn gain to avoid distortion of the output signal. A hysteresis avoids jumping between 2 gain steps for a signal with constant amplitude.

8.3.5 Over-current protection

The over-current protection has a threshold of 150-200mA and a debouncing time of 8 μ s. The stage is forced to OFF mode in an over-current situation. After this the headphone stage tries to power up again every 8ms as long as the over-current situation still exists or the stage is turned off manually.

8.3.6 Parameter

V_{BAT}=1.5V, T_A= 25°C, unless otherwise mentioned

Table 7. Headphone Output Parameter

| Symbol | Parameter | Condition | Min | Typ | Max | Unit |
|---------------------|------------------------------|---|-----|-----|-----|------|
| R _{L_HP} | Load Impedance | stereo mode | 16 | | | Ω |
| C _{L_HP} | Load Capacitance | stereo mode | | | 100 | pF |
| P _{HP} | Nominal Output Power | R _L =16Ω-64Ω | 12 | | | mW |
| P _{SRRHHP} | Power Supply Rejection Ratio | 200Hz-20kHz, 720mVpp, R _L =16Ω | | 90 | | dB |

8.4 Operational Amplifier

8.4.1 General

While AS3410 offers only one operational amplifiers for feed-forward ANC, AS3400 and AS3430 feature an additional second operational amplifier stage to perform feed-back ANC or any other additional needed filtering.

Both operational amplifiers stages can be activated and used individually. While OP1 stage is always configured as inverting amplifier OP2 stage can be also switched to a non-inverting mode with an adjustable gain of 0..+10.5dB.

Figure 13. Operational Amplifiers

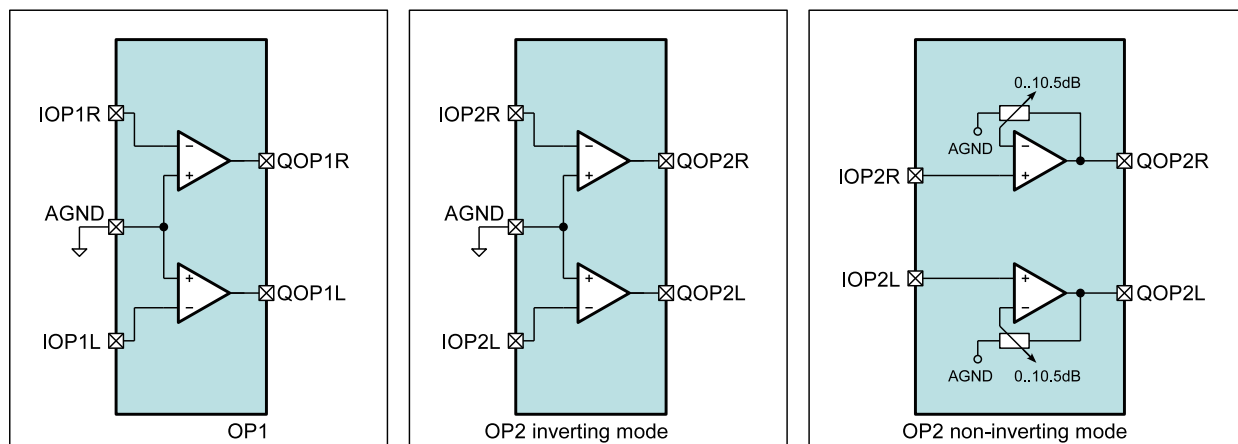

8.4.2 Parameter

V_{BAT}=1.5V, T_A= 25°C, unless otherwise mentioned

Table 8. Headphone Output Parameter

| Symbol | Parameter | Condition | Min | Typ | Max | Unit |
|---------------------|------------------------|--------------|-----|-----|-----|------|
| R _{L_OP} | Load Impedance | single ended | 1 | | | kΩ |
| C _{L_OP} | Load Capacitance | single ended | | | 100 | pF |
| GBW _{OP} | Gain Band Width | | | 4.3 | | MHz |
| V _{OS_OP} | Offset Voltage | | | | 6 | mV |
| V _{EIN_HP} | Equivalent Input Noise | 200Hz-20kHz | | 2.6 | | μV |

8.5 SYSTEM

8.5.1 General

The system block handles the power up and power down sequencing. As well as the mode switching.

8.5.2 Power Up/Down Conditions

The chip powers up when one of the following condition is true:

Table 9. Power UP Conditions

| # | Source | Description |
|---|-----------|---|
| 1 | MODE pin | In stand-alone mode, MODE pin has to be driven high to turn on the device |
| 2 | I2C start | In I2C mode, a I2C start condition turns on the device |

The chip automatically shuts off if one of the following conditions arises:

Table 10. Power DOWN Conditions

| # | Source | Description |
|---|-------------|---|
| 1 | MODE pin | Power down by driving MODE pin to low |
| 2 | SERIF | Power down by SERIF writing 0h to register 20h bit <0> |
| 3 | Low Battery | Power down if VBAT is lower than the supervisor off-threshold |
| 4 | VNEG CP OVC | Power down if VNEG is higher than the VNEG off-threshold |

8.5.3 Start-up Sequence

The start-up sequence depends on the used mode.

In stand-alone mode the sequence runs automatically, in I2C mode the sequence runs till a defined state and waits then for an I2C command. Either the automatic sequence is started by setting the **CONT_PWRUP** bit in addition to the **PWR_HOLD** bit. If only the **PWR_HOLD** is set all enable bits for headphone, microphone, etc have to be set manually.

Figure 14. Stand-Alone Mode Start-Up Sequence

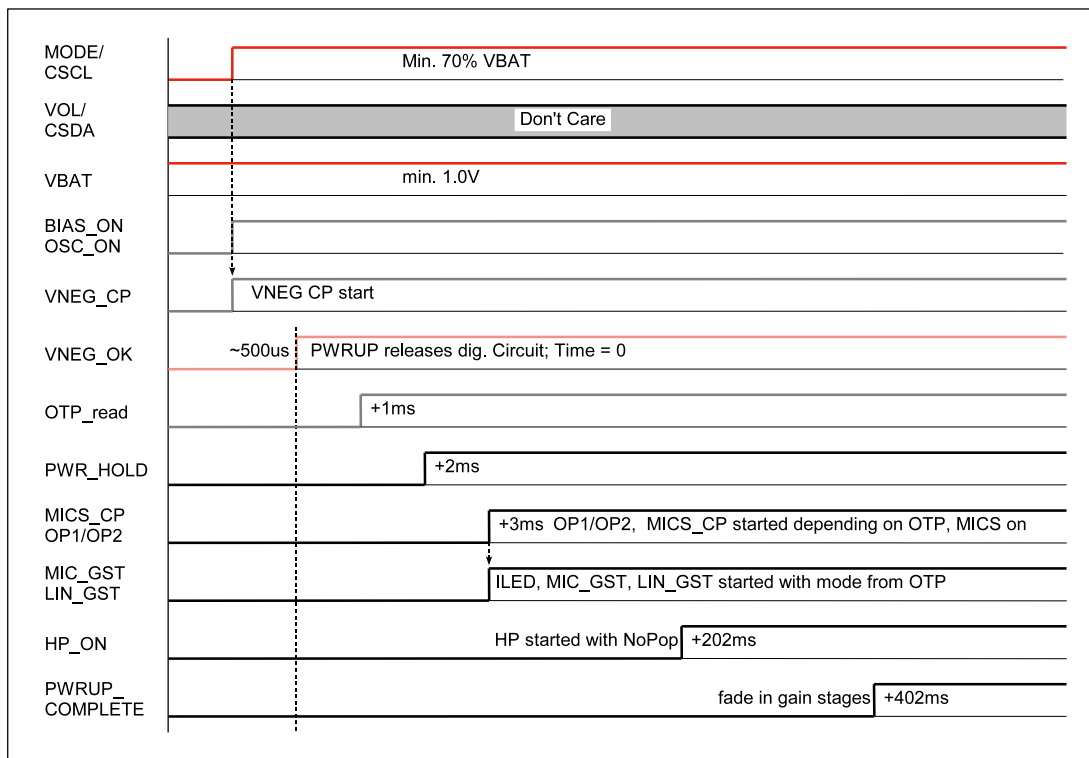
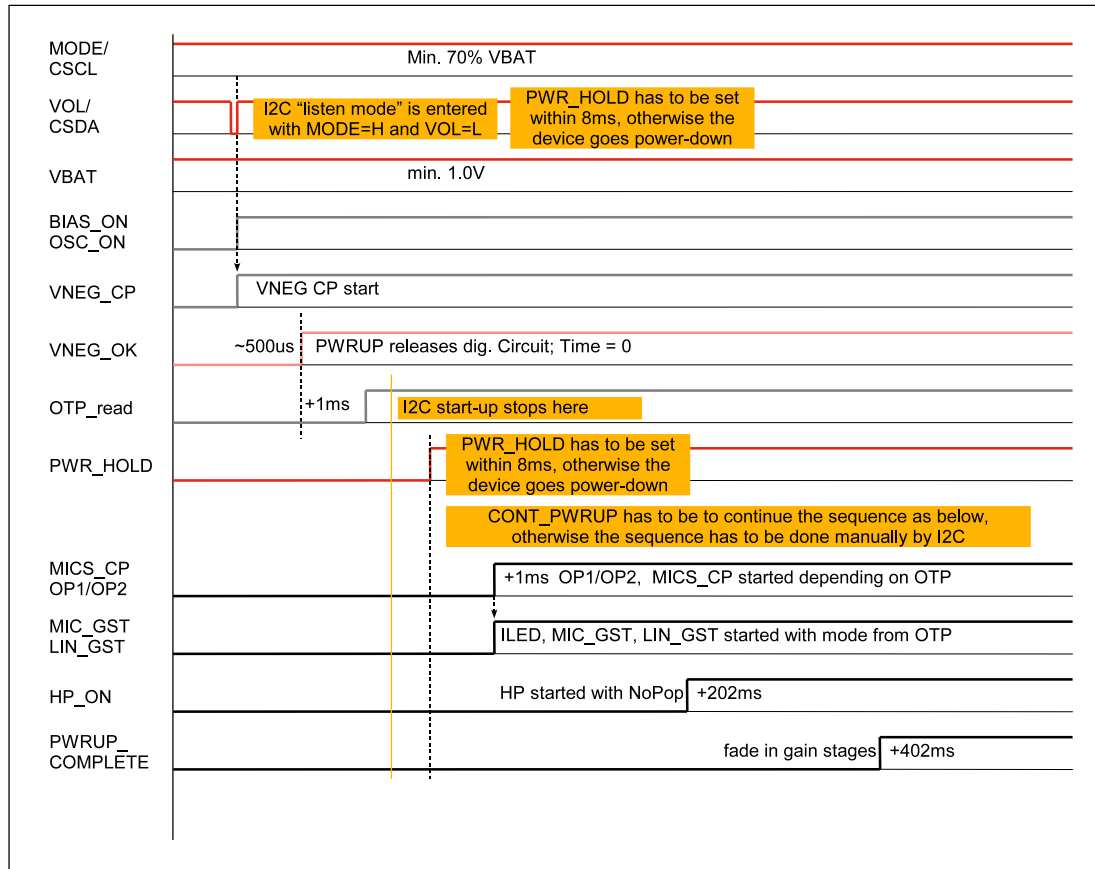

Figure 15. I2C Mode Start-Up Sequence



The total start-up time (including fade-in of the gain stages) can be reduced from 900ms to 600ms by OTP setting.

8.5.4 Mode Switching

When the chip in stand-alone mode (no I2C control) the mode can be switched with different levels on the MODE pin.

Table 11. Operation Modes

| MODE | MODE pin | Description |
|---------|--------------------|---|
| OFF | LOW (VNEG) | Chip is turned off |
| ANC | HIGH (VBAT) | Chip is turned on and active noise cancellation is active |
| MONITOR | TRI-STATE (VBAT/2) | Chip is turned on and monitor mode is active In Monitor mode a different (normally higher) microphone preamplifier gain can be chosen to get an amplification of the surrounding noise. This volume can be either fixed or be controlled by the VOL input. To get rid of the low pass filtering needed for the noise cancellation, the headphone input multiplexer can be set to a different (normally to MIC) source. In addition the LineIn gain can be lowered to reduce the loudness of the music currently played back. |

In I2C mode the monitor mode can be activated by setting the corresponding bit in the system register.

8.5.5 Status Indication

AS3410 and AS3430 features a on-status information via the current output pin ILED. The current can be controlled in 3 steps and be switched off, by setting the PWM to 0%, 25%, 50% or 100% duty cycle of a 50kHz signal.

If LOW_BAT is active, ILED switches to blinking with 1Hz, 50% duty cycle and 50% current setting.

8.6 VNEG Charge Pump

8.6.1 General

The VNEG charge pump uses one external 1uF capacitor to generate a negative supply voltage out of the battery input voltage to supply all audio related blocks. This allows a true-ground headphone output with no more need of external dc-decoupling capacitors.

8.6.2 Parameter

V_{BAT}=1.5V, T_A= 25°C, unless otherwise mentioned

Table 12. Headphone Output Parameter

| Symbol | Parameter | Condition | Min | Typ | Max | Unit |
|------------------|---------------------------|------------------|------|------|------|------|
| V _{IN} | input voltage | V _{BAT} | 1.0 | 1.5 | 1.8 | V |
| V _{OUT} | output voltage | V _{NEG} | -0.7 | -1.5 | -1.8 | V |
| C _{EXT} | external flying capacitor | | | 1 | | uF |

8.7 OTP Memory & Internal Registers

8.7.1 General

The OTP memory consists of OTP register and the OTP fuses. The OTP register can be written as often as wanted but will lose the content on power off. The OTP fuses are intended to store basic chip configurations as well as the microphone gain settings to optimize the ANC performance and get rid of sensitivity variations of different microphones.

Burning the fuses can only be done once and is a permanent change, which means the fuses keep the content even if the chip is powered down. This AS3400/10/30 offers 4 register set for storing the microphone gain making it possible to change the gain 3 times for re-calibration or other purposes.

When the chip is controlled by a microcontroller via I2C, the OTP memory don't has to be used.

8.7.2 Register & OTP Memory configuration

The following graphics is showing the principal register interaction.

Figure 16. Register Access

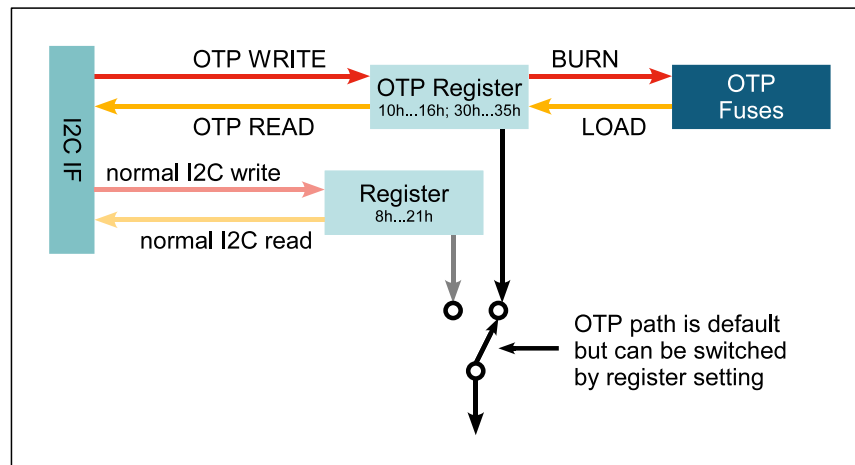

Registers 0x8, 0x9, 0xA, 0xB, 0xC and 0x21 have only effect when the corresponding “REG_ON” bit is set, otherwise the chip operates with the OTP Register settings which are loaded from the OTP fuses at every start-up.

All registers settings can be changed several times, but will lose the content on power off. When using the I2C mode the chip configuration has to be loaded from the microcontroller after every start-up. In stand alone mode the OTP fuses have to be programmed for a permanent change of the chip configuration.

A single OTP cell can be programmed only once. Per default, the cell is "0"; a programmed cell will contain a "1". While it is not possible to reset a programmed bit from "1" to "0", multiple OTP writes are possible, but only additional unprogrammed "0"-bits can be programmed to "1".

Independent of the OTP programming, it is possible to overwrite the OTP register temporarily with an OTP write command at any time. This setting will be cleared and overwritten with the hard programmed OTP settings at each power-up sequence or by a LOAD operation.

The OTP memory can be accessed in the following ways:

LOAD Operation:

The LOAD operation reads the OTP fuses and loads the contents into the OTP register. A LOAD operation is automatically executed after each power-on-reset.

WRITE Operation:

The WRITE operation allows a temporary modification of the OTP register. It does not program the OTP. This operation can be invoked multiple times and will remain set while the chip is supplied with power and while the OTP register is not modified with another WRITE or LOAD operation.

READ Operation:

The READ operation reads the contents of the OTP register, for example to verify a WRITE command or to read the OTP memory after a LOAD command.

BURN Operation:

The BURN operation programs the contents of the OTP register permanently into the OTP fuses. Don't use old or nearly empty batteries for burning the fuses.

Attention: If you once burn the OTP_LOCK bit no further programming, e.g. setting additional "0" to "1", of the OTP can be done.

For production the OTP_LOCK bit must be set to avoid an unwanted change of the OTP content during the lifetime of the product.

8.7.3 OTP fuse burning

In most stand alone applications the I2C pins are not accessible. Burning the fuses can be done by switching the line inputs into a special mode to access the chip by I2C over the line input connections. This allows trimming of the microphone gain with no openings in the final housing and so no influence to the acoustic of the headset.

This mode is called "Application Trimm" mode, or short "APT". (Patent Pending)

During the application trimm mode LINR has to provide the clock, while LINL has to provide the data for the I2C communication.

Please note that the OTP register cannot be accessed directly but have to be enabled before a read or write access. This is independent whether you access the OTP register via the normal I2C pins or in application trimm mode via LINL and LINR. Please refer to the detailed register description to get more information on how the registers can be accessed.

To achieve a proper burning of the fuses, the negative supply has to be buffered by applying an external negative supply during burning. This voltage can also be applied to the LINL terminal. An internal switch is connecting LINL and VNEG during the fuse burning. LINR has to provide the clock for burning the fuses.

The below flow chart shows the principle steps of the OTP burning process. The application trimm mode can only be entered at a specific timing during the start-up sequence.

The device offers the possibility to change microphone gain settings 3 times by using alternative registers. The selection which register set is being used to set the microphone gain is done by the "lock" bits of the corresponding registers.

A more detailed description of the individual steps is available in an application note.

Figure 17. OTP Burning Process

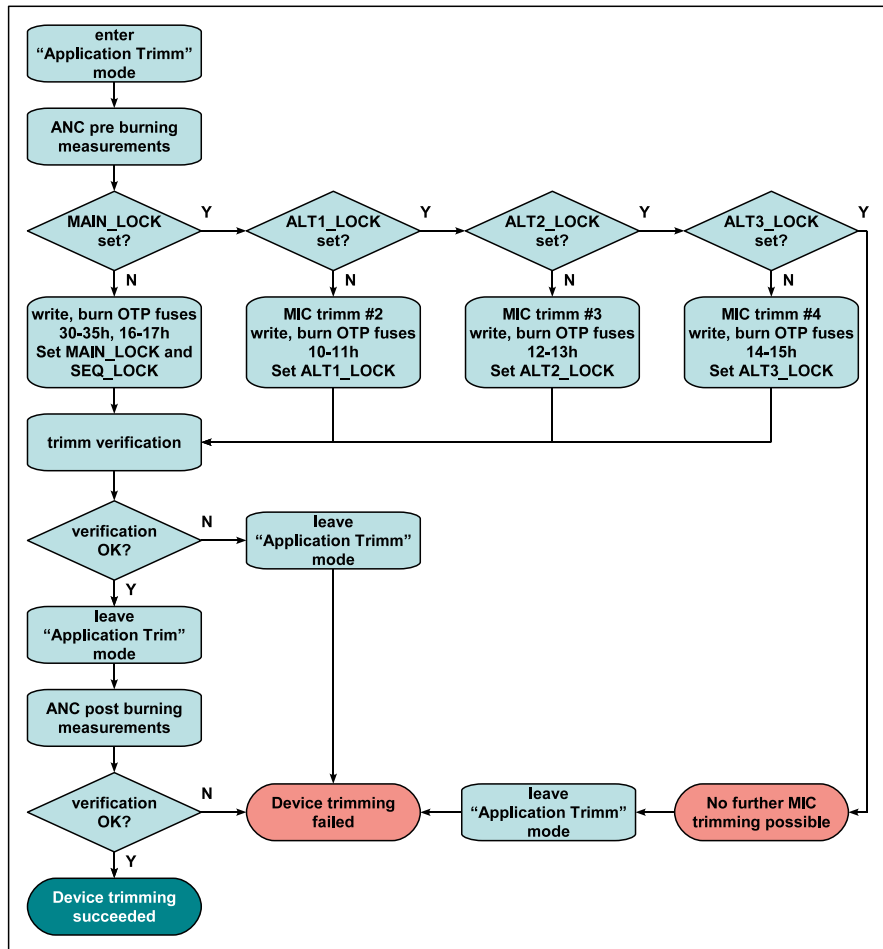

8.8 2-Wire-Serial Control Interface

8.8.1 General

There is an I2C slave block implemented to have access to 64 byte of setting information.

The I2C address is: Adr_Group8 - audio processors

- 8Eh_write
- 8Fh_read

8.8.2 Protocol

Table 13. 2-Wire Serial Symbol Definition

| Symbol | Definition | RW | Note |
|----------|--|----|--------------------|
| S | Start condition after stop | R | 1 bit |
| Sr | Repeated start | R | 1 bit |
| DW | Device address for write | R | 1000 1110b (8Eh) |
| DR | Device address for read | R | 1000 1111b (8Fh) |
| WA | Word address | R | 8 bit |
| A | Acknowledge | W | 1 bit |
| N | No Acknowledge | R | 1 bit |
| reg_data | Register data/write | R | 8 bit |
| data (n) | Register data/read | W | 8 bit |
| P | Stop condition | R | 1 bit |
| WA++ | Increment word address internally | R | during acknowledge |
| | AS3400 AS3410 AS3430 (=slave) receives data | | |
| | AS3400 AS3410 AS3430 (=slave) transmits data | | |

Figure 18. Byte Write

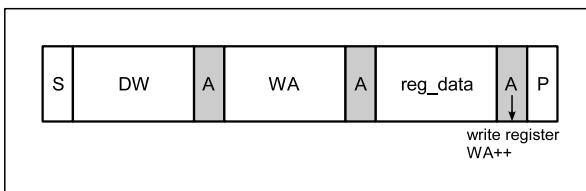
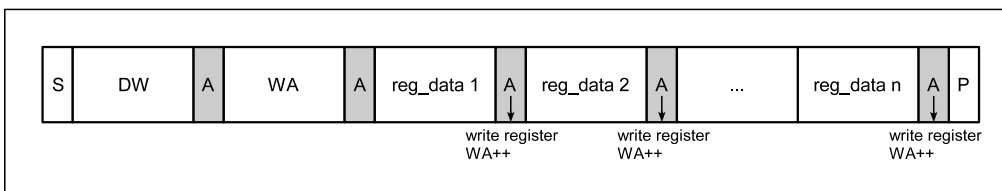

Figure 19. Page Write



Byte Write and Page Write formats are used to write data to the slave.

The transmission begins with the START condition, which is generated by the master when the bus is in IDLE state (the bus is free). The device-write address is followed by the word address. After the word address any number of data bytes can be sent to the slave. The word address is incremented internally, in order to write subsequent data bytes on subsequent address locations.

For reading data from the slave device, the master has to change the transfer direction. This can be done either with a repeated START condition followed by the device-read address, or simply with a new transmission START followed by the device-read address, when the bus is in IDLE state. The device-read address is always followed by the 1st register byte transmitted from the slave. In Read Mode any number of subsequent register bytes can be read from the slave. The word address is incremented internally.

Figure 20. Random Read

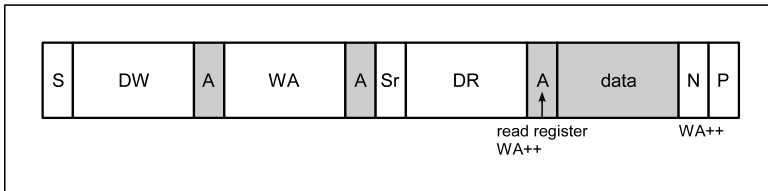

Random Read and Sequential Read are combined formats. The repeated START condition is used to change the direction after the data transfer from the master.

The word address transfer is initiated with a START condition issued by the master while the bus is idle. The START condition is followed by the device-write address and the word address.

In order to change the data direction a repeated START condition is issued on the 1st SCL pulse after the acknowledge bit of the word address transfer. After the reception of the device-read address, the slave becomes the transmitter. In this state the slave transmits register data located by the previous received word address vector. The master responds to the data byte with a not-acknowledge, and issues a STOP condition on the bus.

Figure 21. Sequential Read

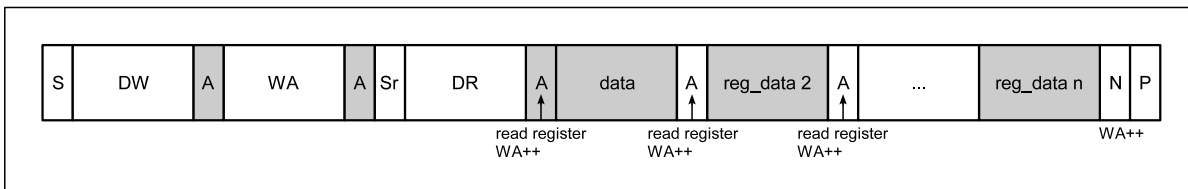

Sequential Read is the extended form of Random Read, as more than one register-data bytes are transferred subsequently. In difference to the Random Read, for a sequential read the transferred register-data bytes are responded by an acknowledge from the master. The number of data bytes transferred in one sequence is unlimited (consider the behavior of the word-address counter). To terminate the transmission the master has to send a not-acknowledge following the last data byte and generate the STOP condition subsequently.

Figure 22. Current Address Read

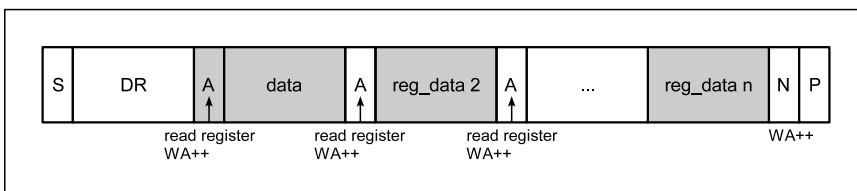

To keep the access time as small as possible, this format allows a read access without the word address transfer in advance to the data transfer. The bus is idle and the master issues a START condition followed by the Device-Read address. Analogous to Random Read, a single byte transfer is terminated with a not-acknowledge after the 1st register byte. Analogous to Sequential Read an unlimited number of data bytes can be transferred, where the data bytes has to be responded with an acknowledge from the master. For termination of the transmission the master sends a not-acknowledge following the last data byte and a subsequent STOP condition.

8.8.3 Parameter

Figure 23. 2-Wire Serial Timing

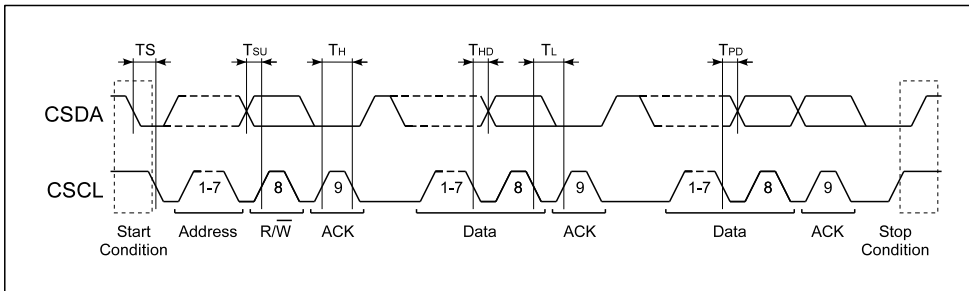

DVDD =2.9V, T_{amb}=25°C; unless otherwise specified

Table 14. 2-Wire Serial Parameter

| Symbol | Parameter | Condition | Min | Typ | Max | Unit |
|------------------|-----------------------------|---|------|-----|------|------|
| V _{CSL} | CSCL, CSDA Low Input Level | (max 30%DVDD) | 0 | - | 0.87 | V |
| V _{CSH} | CSCL, CSDA High Input Level | CSCL, CSDA (min 70%DVDD) | 2.03 | - | 5.5 | V |
| HYST | CSCL, CSDA Input Hysteresis | | 200 | 450 | 800 | mV |
| V _{OL} | CSDA Low Output Level | at 3mA | - | - | 0.4 | V |
| T _{sp} | Spike insensitivity | | 50 | 100 | - | ns |
| T _H | Clock high time | max. 400kHz clock speed | 500 | | | ns |
| T _L | Clock low time | max. 400kHz clock speed | 500 | | | ns |
| T _{SU} | | CSDA has to change Tsetup before rising edge of CSCL | 250 | - | - | ns |
| T _{HD} | | No hold time needed for CSDA relative to rising edge of CSCL | 0 | - | - | ns |
| TS | | CSDA H hold time relative to CSDA edge for start/stop/rep_start | 200 | - | - | ns |
| T _{PD} | | CSDA prop delay relative to lowgoing edge of CSCL | | 50 | | ns |

9 Register Description

Table 15. I2C Register Overview

| Addr | Name | b7 | b6 | b5 | b4 | b3 | b2 | b1 | b0 | |
|------------------------|----------|---|--|---|-------|----------|------------|------------|----------|--|
| Audio Registers | | | | | | | | | | |
| 00-07h | reserved | | | | | | | | | |
| 08h | MIC_L | MIC_MODE 0: StereoSingleEnd 1: MonoDiff | MICL_VOL<6:0> Gain from MICL to QMICL or Mixer = -6dB...+41.6dB; 127 steps of 0.375dB | | | | | | | |
| 09h | MIC_R | MIC_REG_ON 0: use reg 30h & 31h 1: use reg 08h & 09h | MICR_VOL<6:0> Gain from MICR to QMICR or Mixer = -6dB...+41.6dB; 127 steps of 0.375dB | | | | | | | |
| 0Ah | LINE_IN | LIN_REG_ON 0: use reg 33h and VOL pin 1: use reg 0Ah | LIN_MODE 0: StereoSingleEnd 1: MonoDiff | LIN_VOL<5:0> 0: MUTE; 0x01...0x3F: Gain from LINR/L to QLNR/L or Mixer = -46.5dB...+0dB; 63 steps of 0.75dB | | | | | | |
| 0Bh | GP_OP_L | HP_MUX<1:0> 0: MIC; 1: OP1; 2: OP2; 3: open | | OP2L<3:0> 0: OP2L inverting mode; 0x1..0xF: OP2L non inverting mode gain = 0...10.5dB; 15 steps of 0.75dB | | | OP2L_ON | OP1L_ON | | |
| 0Ch | GP_OP_R | OP_REG_ON 0: use reg 34h 1: use reg 0Bh & 0Ch | HP_MODE 0: StereoSingleEnd 1: MonoDiff | OP2R<3:0> 0: OP2R inverting mode; 0x1..0xF: OP2R non inverting mode gain = 0...10.5dB; 15 steps of 0.75dB | | | OP2R_ON | OP1R_ON | | |
| 0Dh-0Fh | reserved | | | | | | | | | |
| 18h-1Fh | reserved | | | | | | | | | |
| System Register | | | | | | | | | | |
| 20h | SYSTEM | Design_Version<3:0> | | | | REG3F_ON | MONITOR_ON | CONT_PWRUP | PWR_HOLD | |
| 21h | PWR_SET | PWR_REG_ON 0: - 1: use reg 21h | ILED<1:0> 0: OFF; 1: 25%; 2: 50%; 3: 100% | | HP_ON | MIC_ON | LIN_ON | MICS_CP_ON | MICS_ON | |
| | | | LOW_BAT | PWRUP_COMPLETE | | | | | | |
| 22h-2Fh | reserved | | | | | | | | | |

Table 15. I2C Register Overview

| Addr | Name | b7 | b6 | b5 | b4 | b3 | b2 | b1 | b0 | |
|---------------------|-----------|--|--|--|---|---|---|---|-------------|--|
| OTP Register | | | | | | | | | | |
| 10h | ANC_L2 | TEST_BIT_5 | MICL_VOL_OTP2<6:0> Gain from MICL to QMICL or Mixer = MUTE, -5.625dB...+41.6dB; 127 steps of 0.375dB | | | | | | | |
| 11h | ANC_R2 | ALT1_LOCK | MICR_VOL_OTP2<6:0> Gain from MICR to QMICR or Mixer = MUTE, -5.625dB...+41.6dB; 127 steps of 0.375dB | | | | | | | |
| 12h | ANC_L3 | TEST_BIT_6 | MICL_VOL_OTP3<6:0> Gain from MICL to QMICL or Mixer = MUTE, -5.625dB...+41.6dB; 127 steps of 0.375dB | | | | | | | |
| 13h | ANC_R3 | ALT2_LOCK | MICR_VOL_OTP3<6:0> Gain from MICR to QMICR or Mixer = MUTE, -5.625dB...+41.6dB; 127 steps of 0.375dB | | | | | | | |
| 14h | ANC_L4 | TEST_BIT_7 | MICL_VOL_OTP4<6:0> Gain from MICL to QMICL or Mixer = MUTE, -5.625dB...+41.6dB; 127 steps of 0.375dB | | | | | | | |
| 15h | ANC_R4 | ALT3_LOCK | MICR_VOL_OTP4<6:0> Gain from MICR to QMICR or Mixer = MUTE, -5.625dB...+41.6dB; 127 steps of 0.375dB | | | | | | | |
| 17h | PWRUP | SEQ_LOCK | FAST_START<4:0> 0: ~900ms; 1: ~600ms | | | | | LIN_AGC_OFF | MIC_AGC_OFF | |
| 30h | ANC_L | TEST_BIT_1 | MICL_VOL_OTP<6:0> Gain from MICL to QMICL or Mixer = MUTE, -5.625dB...+41.6dB; 127 steps of 0.375dB | | | | | | | |
| 31h | ANC_R | TEST_BIT_2 | MICR_VOL_OTP<6:0> Gain from MICR to QMICR or Mixer = MUTE, -5.625dB...+41.6dB; 127 steps of 0.375dB | | | | | | | |
| 32h | MIC_MON | MON_MODE 0: fixed volume 1: adj. volume | MIC_MON_OTP<6:0> Gain from MICI/R to QMICL/R or Mixer = MUTE, -5.625dB...+41.6dB; 0.375dB steps, if MON_MODE is set to 0 Gain from MICI/R to QMICL/R or Mixer = MUTE, -5.625dB...+41.6dB; 0.375dB steps, adjustable by VOL pin if MON_MODE is set to 1 | | | | | | | |
| 33h | AUDIO_SET | VOL_PIN_OFF | VOL_PIN_MODE 0: potentiometer 1: up/down button | LIN_MODE_OTP 0: StereoSingleEnd 1: MonoDiff | MIC_MODE_OTP 0: StereoSingleEnd 1: MonoDiff | HP_MODE_OTP 0: StereoSingleEnd 1: MonoDiff | LIN_MON_ATTEN<2:0> 0: no attenuation; 1..6: LIN_VOL<6:0> shift by -6dB...-36dB 7: MUTE | | | |
| 34h | GP_OP | HP_MUX_OTP<1:0> 0: MIC; 1: OP1; 2: OP2; 3: - | | OP2_OTP<3:0> 0: OP2 inverting mode; 0x1..0xF: OP2 non inverting mode gain = 0...10.5dB; 15 steps of 0.75dB | | | OP2_ON_OTP | OP1_ON_OTP | | |
| 35h | OTP_SYS | MAIN_LOCK 0: write reg 30h..35h 1: lock reg 30h..35h | TEST_BIT_3 | MON_HP_MUX<1:0> 0: MIC; 1: OP1; 2: OP2; 3: - | | ILED_OTP<1:0> 0: OFF; 1: 25%; 2: 50%; 3: 100% | | MICS_CP_OFF | I2C_MODE | |
| 3Eh | CONFIG_1 | | | | | EXTBURNCLK | | | | |
| 3Fh | CONFIG_2 | | | | BURNSW | TM_REG34-35 | TM_REG30-33 | OTP_MODE<1:0> 0: READ; 1: LOAD; 2: WRITE; 3: BURN | | |

Table 16. MIC_L Register

| Name | | Base | | Default |
|-------------|---------------|---|--------|--|
| MIC_L | | 2-wire serial | | 00h |
| Offset: 08h | | Left Microphone Input Register | | |
| | | Configures the gain for the left microphone input and defines the microphone operation mode. This register is reset at POR. | | |
| Bit | Bit Name | Default | Access | Bit Description |
| 7 | MIC_MODE | 0 | R/W | Selects the microphone input mode 0: single ended stereo mode 1: mono differential mode |
| 6:0 | MICL_VOL<6:0> | 000 0000 | R/W | Volume settings for left microphone input, adjustable in 127 steps of 0.375dB 00 0000: MUTE 00 0001: -5.625dB gain 00 0010: -5.25 dB gain .. 11 1110: 41.250dB gain 11 1111: 41.625 dB gain |

Table 17. MIC_R Register

| Name | | Base | | Default |
|-------------|---------------|---|--------|---|
| MIC_R | | 2-wire serial | | 00h |
| Offset: 09h | | Right Microphone Input Register | | |
| | | Configures the gain for the right microphone input and enables register 08h & 09h. This register is reset at POR. | | |
| Bit | Bit Name | Default | Access | Bit Description |
| 7 | MIC_REG_ON | 0 | R/W | Defines which registers are used for the microphone settings. 0: settings of register 30h and 31h are used 1: settings of register 08h and 09h are used |
| 6:0 | MICR_VOL<6:0> | 000 0000 | R/W | Volume settings for right microphone input, adjustable in 127 steps of 0.375dB 00 0000: MUTE 00 0001: -5.625dB gain 00 0010: -5.25 dB gain .. 11 1110: 41.250dB gain 11 1111: 41.625 dB gain |

Table 18. LINE_IN Register

| Name | | Base | | Default |
|-------------|--------------|---|--------|---|
| LINE_IN | | 2-wire serial | | 00h |
| Offset: 0Ah | | Line Input Register | | |
| | | Configures the attenuation for the line input, defines the line input operation mode and enables register 0Ah. This register is reset at POR. | | |
| Bit | Bit Name | Default | Access | Bit Description |
| 7 | LIN_REG_ON | 0 | R/W | Defines which source is used for the line input settings. 0: settings of register 33h and VOL pin are used 1: register 0Ah is used |
| 6 | LIN_MODE | 0 | R/W | Selects the line input mode 0: single ended stereo mode 1: mono differential mode |
| 5:0 | LIN_VOL<5:0> | 00 0000 | R/W | Volume settings for line input, adjustable in 63 steps of 0.75dB 00 0000: MUTE 00 0001:-46.5dB gain 00 0010:-45.75dB gain .. 11 1110:-0.75dB gain 11 1111:.0 dB gain |

Table 19. GP_OP_L Register

| Name | | Base | | Default |
|-------------|-------------|--|--------|---|
| GP_OP_L | | 2-wire serial | | 00h |
| Offset: 0Bh | | Left General Purpose Operational Amplifier Register | | |
| | | Enables the left opamp stages, defines opamp 2 mode and gain and sets the HP input multiplexer. This register is reset at POR. | | |
| Bit | Bit Name | Default | Access | Bit Description |
| 7:6 | HP_MUX<1:0> | 00 | R/W | Multiplexes the analog audio signal to HP amp 00: MIC: selects QMICL/R output 01: OP1: selects QOP1L/R outputs 10:OP2: selects QOP2L/R output 11: open: no signal mixed together with the line input signal |
| 5:2 | OP2L<3:0> | 0000 | R/W | Mode and volume settings for left OP2, adjustable in 15 steps of 0.75dB 0000: OP2L in inverting mode 0001: 0 dB gain, OP2L in non inverting mode 0001: 0.75 dB gain, non inverting .. 1110: 9.75dB gain, non inverting 1111:.10.5 dB gain, non inverting |
| 1 | OP2L_ON | 0 | R/W | Enables left OP 2 0: left OP2 is switched off 1: left OP2 is enabled |
| 0 | OP1L_ON | 0 | R/W | Enables left OP 1 0: left OP1 is switched off 1: left OP1 is enabled |

Table 20. GP_OP_R Register

| Name | | Base | | Default |
|--|-----------|--|--------|---|
| GP_OP_R | | 2-wire serial | | 00h |
| Offset: 0Ch | | Right General Purpose Operational Amplifier Register | | |
| Enables the right opamp stages, defines opamp 2 mode and gain and sets the HP mode. This register is reset at POR. | | | | |
| Bit | Bit Name | Default | Access | Bit Description |
| 7 | OP_REG_ON | 0 | R/W | Defines which register is used for the opamp and HP settings. 0: settings of register 33h and 34h are used 1: register 0B and 0Ch are used |
| 6 | HP_MODE | 0 | R/W | Selects the line input mode 0: single ended stereo mode 1: mono differential mode |
| 5:2 | OP2R<3:0> | 0000 | R/W | Mode and volume settings for right OP2, adjustable in 15 steps of 0.75dB 0000: OP2R in inverting mode 0001: 0 dB gain, OP2R in non inverting mode 0001: 0.75 dB gain, non inverting ... 1110: 9.75dB gain, non inverting 1111: 10.5 dB gain, non inverting |
| 1 | OP2R_ON | 0 | R/W | Enables right OP 2 0: right OP2 is switched off 1: right OP2 is enabled |
| 0 | OP1R_ON | 0 | R/W | Enables right OP 1 0: right OP1 is switched off 1: right OP1 is enabled |

Table 21. SYSTEM Register

| Name | | Base | | Default |
|----------------------------------|---------------------|-----------------|--------|--|
| SYSTEM | | 2-wire serial | | 31h |
| Offset: 20h | | SYSTEM Register | | |
| This register is reset at a POR. | | | | |
| Bit | Bit Name | Default | Access | Bit Description |
| 7:4 | Design_Version<3:0> | 0011 | R | AFE number to identify the design version 0011: for chip version 1v2 |
| 3 | TESTREG_ON | 0 | R/W | 0: normal operation 1: enables writing to test register 3Eh & 3Fh to configure the OTP and set the access mode. |
| 2 | MONITOR_ON | 0 | R/W | Enables the monitor mode 0: normal operation 1: monitor mode enabled |
| 1 | CONT_PWRUP | 0 | R/W | Continues the automatic power-up sequence when using the I2C mode 0: chip stops the power-up sequence after the supplies are stable, switching on individual blocks has to be done via I2C commands 1: automatic power-up sequence is continued |
| 0 | PWR_HOLD | 1 | R/W | 0: power up hold is cleared and AFE will power down 1: is automatically set to on after power on |

Table 22. PWR_SET Register

| Name | | Base | | Default |
|-------------|----------------|---|--------|---|
| PWR_SET | | 2-wire serial | | 0x11 1111b (stand alone mode) 0x00 0000b (I2C mode) |
| Offset: 21h | | Power Setting Register | | |
| | | Please be aware that writing to this register will enable/disable the corresponding blocks, while reading gets the actual status. It is not possible to read back e.g ILED settings. This register is reset at POR. | | |
| Bit | Bit Name | Default | Access | Bit Description |
| 7 | PWR_REG_ON | 0 | R/W | Defines which register is used for the power settings. 0: all blocks stay on as defined in the start-up sequence 1: register 21h is used |
| 6:5 | ILED<1:0> | 00 | W | Sets the current sunk into ILED 00: current sink switched OFF 01: 25% 10: 50% 11: 100% |
| 6 | LOW_BAT | x | R | VBAT supervisor status 0: VBAT is above brown out level 1: BVDD has reached brown out level |
| 5 | PWRUP_COMPLETE | x | R | Power-Up sequencer status 0: power-up sequence incomplete 1: power-up sequence completed |
| 4 | HP_ON | 0 | W | 0: switches HP stage off 1: switches HP stage on |
| | | x | R | 0: HP stage not powered 1: normal operation |
| 3 | MIC_ON | 0 | W | 0: switches microphone stage off 1: switches microphone stage on |
| | | x | R | 0: microphone stage not powered 1: normal operation |
| 2 | LIN_ON | 0 | W | 0: switches line input stage off 1: switches line input stage on |
| | | x | R | 0: line input stage not powered 1: normal operation |
| 1 | MICS_CP_ON | 0 | W | 0: switches microphone supply charge pump off 1: switches microphone supply charge pump on |
| | | x | R | 0: microphone supply charge pump not powered 1: normal operation |
| 0 | MICS_ON | 0 | W | 0: switches microphone supply off 1: switches microphone supply on |
| | | x | R | 0: microphone supply not enabled 1: normal operation |

Table 23. ANC_L2 Register

| Name | | Base | | Default |
|-------------|------------------------|---|--------|--|
| ANC_L2 | | 2-wire serial | | 80h (OTP) |
| Offset: 10h | | Left OTP Microphone Input Register (2nd OTP option) | | |
| | | Configures the gain for the left microphone input. This is a special register, writing needs to be enabled by writing 10b to Reg 3Fh first. This register is reset at POR and gets loaded with the OTP fuse contents. | | |
| Bit | Bit Name | Default | Access | Bit Description |
| 7 | TEST_BIT_5 | 1 | R | for testing purpose only |
| 6:0 | MICL_VOL_OTP2 <6:0> | 000 0000 | R/W | Volume settings for left microphone input, adjustable in 127 steps of 0.375dB 00 0000: MUTE 00 0001: -5.625dB gain 00 0010: -5.25 dB gain .. 11 1110: 41.250dB gain 11 1111: 41.625 dB gain |

Table 24. ANC_R2 Register

| Name | | Base | | Default |
|-------------|------------------------|---|--------|---|
| ANC_R2 | | 2-wire serial | | 00h (OTP) |
| Offset: 11h | | Right OTP Microphone Input Register (2nd OTP option) | | |
| | | Configures the gain for the left microphone input. This is a special register, writing needs to be enabled by writing 10b to Reg 3Fh first. This register is reset at POR and gets loaded with the OTP fuse contents. | | |
| Bit | Bit Name | Default | Access | Bit Description |
| 7 | ALT1_LOCK | 0 | R/W | 0: additional bits can be fused inside register 10h & 11h 1: OTP fusing for register 10h & 11h gets locked, no more changes can be done. |
| 6:0 | MICR_VOL_OTP2 <6:0> | 000 0000 | R/W | Volume settings for right microphone input, adjustable in 127 steps of 0.375dB 00 0000: MUTE 00 0001: -5.625dB gain 00 0010: -5.25 dB gain .. 11 1110: 41.250dB gain 11 1111: 41.625 dB gain |

Table 25. ANC_L3 Register

| Name | | Base | | Default |
|-------------|------------------------|---|--------|--|
| ANC_L3 | | 2-wire serial | | 80h (OTP) |
| Offset: 12h | | Left OTP Microphone Input Register (3rd OTP option) | | |
| | | Configures the gain for the left microphone input. This is a special register, writing needs to be enabled by writing 10b to Reg 3Fh first. This register is reset at POR and gets loaded with the OTP fuse contents. | | |
| Bit | Bit Name | Default | Access | Bit Description |
| 7 | TEST_BIT_6 | 1 | R | for testing purpose only |
| 6:0 | MICL_VOL_OTP3 <6:0> | 000 0000 | R/W | Volume settings for left microphone input, adjustable in 127 steps of 0.375dB 00 0000: MUTE 00 0001: -5.625dB gain 00 0010: -5.25 dB gain .. 11 1110: 41.250dB gain 11 1111: 41.625 dB gain |

Table 26. ANC_R3 Register

| Name | | Base | | Default |
|-------------|------------------------|---|--------|---|
| ANC_R3 | | 2-wire serial | | 00h (OTP) |
| Offset: 13h | | Right OTP Microphone Input Register (3rd OTP option) | | |
| | | Configures the gain for the left microphone input. This is a special register, writing needs to be enabled by writing 10b to Reg 3Fh first. This register is reset at POR and gets loaded with the OTP fuse contents. | | |
| Bit | Bit Name | Default | Access | Bit Description |
| 7 | ALT2_LOCK | 0 | R/W | 0: additional bits can be fused inside register 12h & 13h 1: OTP fusing for register 12h & 13h gets locked, no more changes can be done. |
| 6:0 | MICR_VOL_OTP3 <6:0> | 000 0000 | R/W | Volume settings for right microphone input, adjustable in 127 steps of 0.375dB 00 0000: MUTE 00 0001: -5.625dB gain 00 0010: -5.25 dB gain .. 11 1110: 41.250dB gain 11 1111: 41.625 dB gain |

Table 27. ANC_L4 Register

| Name | | Base | | Default |
|-------------|------------------------|---|--------|--|
| ANC_L4 | | 2-wire serial | | 80h (OTP) |
| Offset: 14h | | Left OTP Microphone Input Register (4th OTP option) | | |
| | | Configures the gain for the left microphone input. This is a special register, writing needs to be enabled by writing 10b to Reg 3Fh first. This register is reset at POR and gets loaded with the OTP fuse contents. | | |
| Bit | Bit Name | Default | Access | Bit Description |
| 7 | TEST_BIT_7 | 1 | R | for testing purpose only |
| 6:0 | MICL_VOL_OTP4 <6:0> | 000 0000 | R/W | Volume settings for left microphone input, adjustable in 127 steps of 0.375dB 00 0000: MUTE 00 0001: -5.625dB gain 00 0010: -5.25 dB gain .. 11 1110: 41.250dB gain 11 1111: 41.625 dB gain |

Table 28. ANC_R4 Register

| Name | | Base | | Default |
|-------------|------------------------|---|--------|---|
| ANC_R4 | | 2-wire serial | | 00h (OTP) |
| Offset: 15h | | Right OTP Microphone Input Register (4th OTP option) | | |
| | | Configures the gain for the left microphone input. This is a special register, writing needs to be enabled by writing 10b to Reg 3Fh first. This register is reset at POR and gets loaded with the OTP fuse contents. | | |
| Bit | Bit Name | Default | Access | Bit Description |
| 7 | ALT3_LOCK | 0 | R/W | 0: additional bits can be fused inside register 14h & 15h 1: OTP fusing for register 14h & 15h gets locked, no more changes can be done. |
| 6:0 | MICR_VOL_OTP4 <6:0> | 000 0000 | R/W | Volume settings for right microphone input, adjustable in 127 steps of 0.375dB 00 0000: MUTE 00 0001: -5.625dB gain 00 0010: -5.25 dB gain .. 11 1110: 41.250dB gain 11 1111: 41.625 dB gain |

Table 29. PWRUP_CNTR Register

| Name | | Base | | Default |
|-------------|---------------------|--|--------|--|
| PWRUP_CNTR | | 2-wire serial | | 00h (OTP) |
| Offset: 17h | | PowerUp Control Register | | |
| | | Configures chip start-up speed. This is a special register, writing needs to be enabled by writing 10b to Reg 3Fh first. This register is reset at POR and gets loaded with the OTP fuse contents. | | |
| Bit | Bit Name | Default | Access | Bit Description |
| 7 | SEQ_LOCK | 0 | R/W | 0: additional bits can be fused inside register 16h & 17h 1: OTP fusing for register 16h & 17h gets locked, no more changes can be done. |
| 6:2 | FAST_START <4:0> | 0 0000 | R/W | 0h: ~900ms start-up time 0Eh: ~600ms start-up time |
| 1 | LIN_AGC_OFF | 0 | R/W | 0: Line Input AGC enabled 1: Line Input AGC switched off |
| 0 | MIC_AGC_OFF | 0 | R/W | 0: Microphone Input AGC enabled 1: Microphone Input AGC switched off |

Table 30. ANC_L Register

| Name | | Base | | Default |
|-------------|-----------------------|---|--------|--|
| ANC_L | | 2-wire serial | | 80h (OTP) |
| Offset: 30h | | Left OTP Microphone Input Register | | |
| | | Configures the gain for the left microphone input. This is a special register, writing needs to be enabled by writing 10b to Reg 3Fh first. This register is reset at POR and gets loaded with the OTP fuse contents. | | |
| Bit | Bit Name | Default | Access | Bit Description |
| 7 | TEST_BIT_1 | 1 | R | for testing purpose only |
| 6:0 | MICL_VOL_OTP <6:0> | 000 0000 | R/W | Volume settings for left microphone input, adjustable in 127 steps of 0.375dB 00 0000: MUTE 00 0001: -5.625dB gain 00 0010: -5.25 dB gain .. 11 1110: 41.250dB gain 11 1111: 41.625 dB gain |

Table 31. ANC_R Register

| Name | | Base | | Default |
|-------------|-----------------------|---|--------|---|
| ANC_R | | 2-wire serial | | 80h (OTP) |
| Offset: 31h | | Right OTP Microphone Input Register | | |
| | | Configures the gain for the left microphone input. This is a special register, writing needs to be enabled by writing 10b to Reg 3Fh first. This register is reset at POR and gets loaded with the OTP fuse contents. | | |
| Bit | Bit Name | Default | Access | Bit Description |
| 7 | TEST_BIT_2 | 1 | R | for testing purpose only |
| 6:0 | MICR_VOL_OTP <6:0> | 000 0000 | R/W | Volume settings for right microphone input, adjustable in 127 steps of 0.375dB 00 0000: MUTE 00 0001: -5.625dB gain 00 0010: -5.25 dB gain .. 11 1110: 41.250dB gain 11 1111: 41.625 dB gain |

Table 32. MIC_MON Register

| Name | | Base | | Default |
|-------------|----------------------|--|--------|--|
| MIC_MON | | 2-wire serial | | 00h (OTP) |
| Offset: 32h | | OPT Microphone Monitor Mode Register | | |
| | | Configures the gain for the microphone input in monitor mode. This is a special register, writing needs to be enabled by writing 10b to Reg 3Fh first. This register is reset at POR and gets loaded with the OTP fuse contents. | | |
| Bit | Bit Name | Default | Access | Bit Description |
| 7 | MON_MODE | 0 | R/W | 0: monitor mode is working with fixed microphone gain 1: monitor mode uses adjustable gain via the VOL pin |
| 6:0 | MIC_MON_OTP <6:0> | 000 0000 | R/W | Volume settings for microphone input during monitor mode, adjustable in 127 steps of 0.375dB. If MON_MODE bit is set to 1 the gain can be further adjusted via the VOL pin. 00 0000: MUTE 00 0001: -5.625dB gain 00 0010: -5.25 dB gain .. 11 1110: 41.250dB gain 11 1111: 41.625 dB gain |

Table 33. AUDIO_SET Register

| Name | | Base | | Default |
|-------------|------------------------|---|--------|--|
| AUDIO_SET | | 2-wire serial | | 00h (OTP) |
| Offset: 33h | | OPT Audio Setting Register | | |
| | | Configures the audio settings. This is a special register, writing needs to be enabled by writing 10b to Reg 3Fh first. This register is reset at POR and gets loaded with the OTP fuse contents. | | |
| Bit | Bit Name | Default | Access | Bit Description |
| 7 | VOL_PIN_OFF | 0 | R/W | 0: VOL pin is enabled 1: line in volume settings can only be done via I2C. VOL_PIN_MODE has to be set to 1 in this mode. |
| 6 | VOL_PIN_MODE | 0 | R/W | 0: VOL pin is in potentiometer mode 1: VOL pin is in up/down button mode |
| 5 | LIN_MODE_OTP | 0 | R/W | 0: line input stage operating in single ended mode 1: line input operating in mono balanced |
| 4 | MIC_MODE_OTP | 0 | R/W | 0: microphone input stage operating in single ended mode 1: normal operating in mono balanced |
| 3 | HP_MODE_OTP | 0 | R/W | 0: headphone stage operating in single ended mode 1: normal operating in mono balanced |
| 2:0 | LIN_MON_ATTEN <6:0> | 000 | R/W | Volume settings for line input during monitor mode, adjustable in 7 steps of 6dB and mute. 000: 0dB gain 001: -6dB gain .. 110: -36dB gain 111: MUTE |

Table 34. GP_OP Register

| Name | | Base | | Default |
|-------------|-----------------|---|--------|---|
| GP_OP | | 2-wire serial | | 00h (OTP) |
| Offset: 34h | | OTP General Purpose Operational Amplifier Register | | |
| | | Enables the opamp stages, defines opamp 2 mode and gain and sets the HP input multiplexer. This is a special register, writing needs to be enabled by writing 10b to Reg 3Fh first. This register is reset at POR and gets loaded with the OTP fuse contents. | | |
| Bit | Bit Name | Default | Access | Bit Description |
| 7:6 | HP_MUX_OTP<1:0> | 00 | R/W | Multiplexes the analog audio signal to HP amp 00: MIC: selects QMICL/R output 01:OP1: selects QOP1L/R outputs 10:OP2: selects QOP2L/R output 11: open: no signal mixed together with the line input signal |
| 5:2 | OP2_OTP<3:0> | 0000 | R/W | Mode and volume settings for OP2, adjustable in 15 steps of 0.75dB 0000: OP2L in inverting mode 0001: 0 dB gain, OP2L in non inverting mode 0001: 0.75 dB gain, non inverting ... 1110: 9.75dB gain, non inverting 1111: 10.5 dB gain, non inverting |
| 1 | OP2_ON | 0 | R/W | 0: OP2 is switched off 1: left OP2 is enabled |
| 0 | OPL_ON | 0 | R/W | 0: OP1 is switched off 1: OP1 is enabled |

Table 35. OTP_SYS Register

| Name | | Base | | Default |
|-------------|---------------------|---|--------|--|
| OTP_SYS | | 2-wire serial | | 40h (OTP) |
| Offset: 35h | | OTP System Settings Register | | |
| | | Defines several system settings for OTP operation. This is a special register, writing needs to be enabled by writing 10b to Reg 3Fh first. This register is reset at POR and gets loaded with the OTP fuse contents. | | |
| Bit | Bit Name | Default | Access | Bit Description |
| 7 | MAIN_LOCK | 0 | R/W | 0: additional bits can be fused inside the OTP 1: OTP fusing gets locked, no more changes can be done |
| 6 | TEST_BIT_3 | 1 | R | for testing purpose only |
| 5:4 | MON_HP_MUX <1:0> | 00 | R/W | Multiplexes the analog audio signal to HP amp in monitor mode 00: MIC: selects QMICL/R output 01: OP1: selects QOP1L/R outputs 10:OP2: selects QOP2L/R output 11: open: no signal mixed together with the line input signal |
| 3:2 | ILED_OTP<1:0> | 00 | W | Sets the current sunk into ILED 00: current sink switched OFF 01: 25% 10: 50% 11: 100% |

Table 35. OTP_SYS Register

| Name | | Base | | Default |
|-------------|-------------|---|--------|--|
| OTP_SYS | | 2-wire serial | | 40h (OTP) |
| Offset: 35h | | OTP System Settings Register | | |
| | | Defines several system settings for OTP operation. This is a special register, writing needs to be enabled by writing 10b to Reg 3Fh first. This register is reset at POR and gets loaded with the OTP fuse contents. | | |
| Bit | Bit Name | Default | Access | Bit Description |
| 1 | MICS_CP_OFF | 0 | R/W | 0: MICS charge pump is enabled 1: MICS charge pump is switched off |
| 0 | I2C | 0 | R/W | 0: I2C and stand alone mode start-up possible 1: chip starts-up in I2C mode only |

Table 36. CONFIG_1 Register

| Name | | Base | | Default |
|-------------|------------|---|--------|--|
| CONFIG_1 | | 2-wire serial | | 00h |
| Offset: 3Eh | | OTP Configuration Register | | |
| | | Controls the clock configuration. This is a special register, writing needs to be enabled by writing 9h to Reg 20h first. This register is reset at POR and gets loaded with the OTP fuse contents. | | |
| Bit | Bit Name | Default | Access | Bit Description |
| 7:4 | - | 0000 | n/a | |
| 3 | EXTBURNCLK | 0 | n/a | 0: ext. clock for OTP burning disabled 1: ext. clock for OTP burning enabled |
| 2:0 | - | 000 | n/a | |

Table 37. CONFIG_2 Register

| Name | | Base | | Default |
|-------------|---------------|--|--------|--|
| CONFIG_2 | | 2-wire serial | | 00h |
| Offset: 3Fh | | OTP Access Configuration Register | | |
| | | Controls the OTP access. This is a special register, writing needs to be enabled by writing 9h to Reg 20h first. This register is reset at POR and gets loaded with the OTP fuse contents. | | |
| Bit | Bit Name | Default | Access | Bit Description |
| 7:5 | - | 000 | n/a | |
| 4 | BURNSW | 0 | n/a | 0: BURN switch from LINL to VNEG is disabled 1: BURN switch from LINL to VNEG is enabled |
| 3 | TM_REG34-35 | 0 | n/a | 0: test mode for Register 34h-35h disabled 1: test mode for Register 34h-35h enabled |
| 2 | TM_REG30-33 | 0 | n/a | 0: test mode for Register 30h-33h disabled 1: test mode for Register 30h-33h enabled |
| 1:0 | OTP_MODE<1:0> | 00 | R/W | Controls the OTP access 00: READ 01: LOAD 10: WRITE 11: BURN |

10 Application Information

Figure 24. AS3410 High Performance Application in Bridged Mode for high impedance headsets

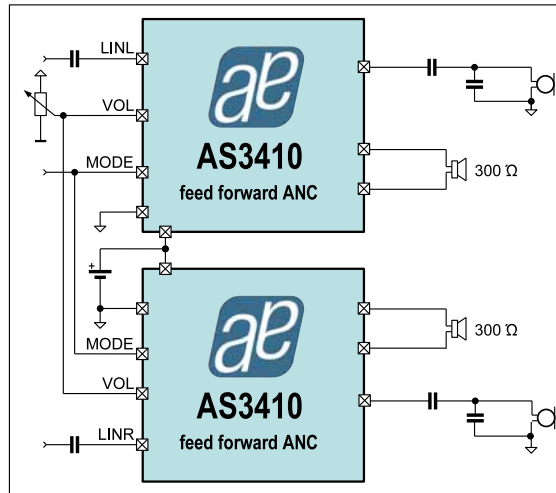

For high impedance headphones two AS3410 can be used in a bridged mode each one driving one side of the headphone load as differential output to get 24mW output power per channel. Also the microphone inputs can be used in differential mode to reduce the noise level.

Figure 25. AS3400 Feed-Forward ANC Block Diagram

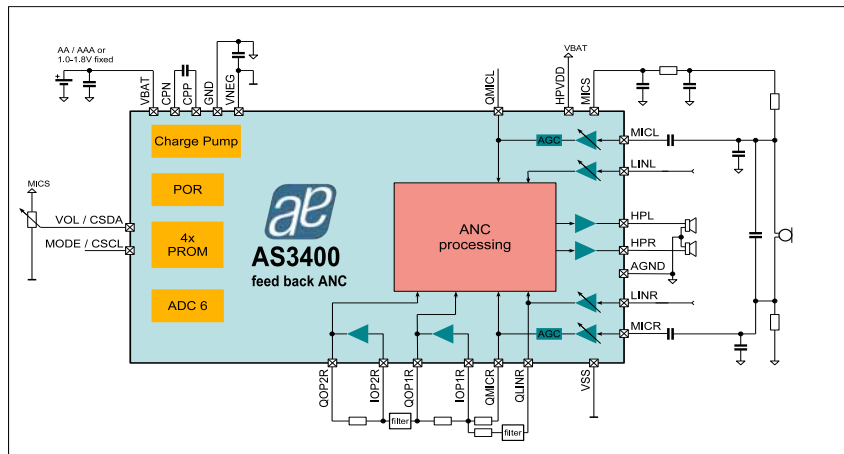

Figure 26. AS3430 on Music Player with ANC

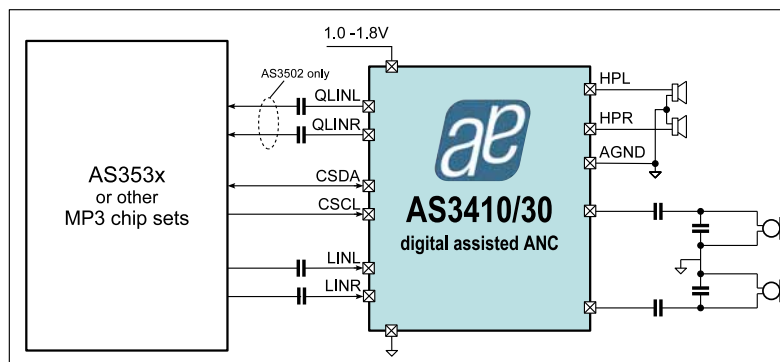

Figure 27. AS3501 feed-forward application example

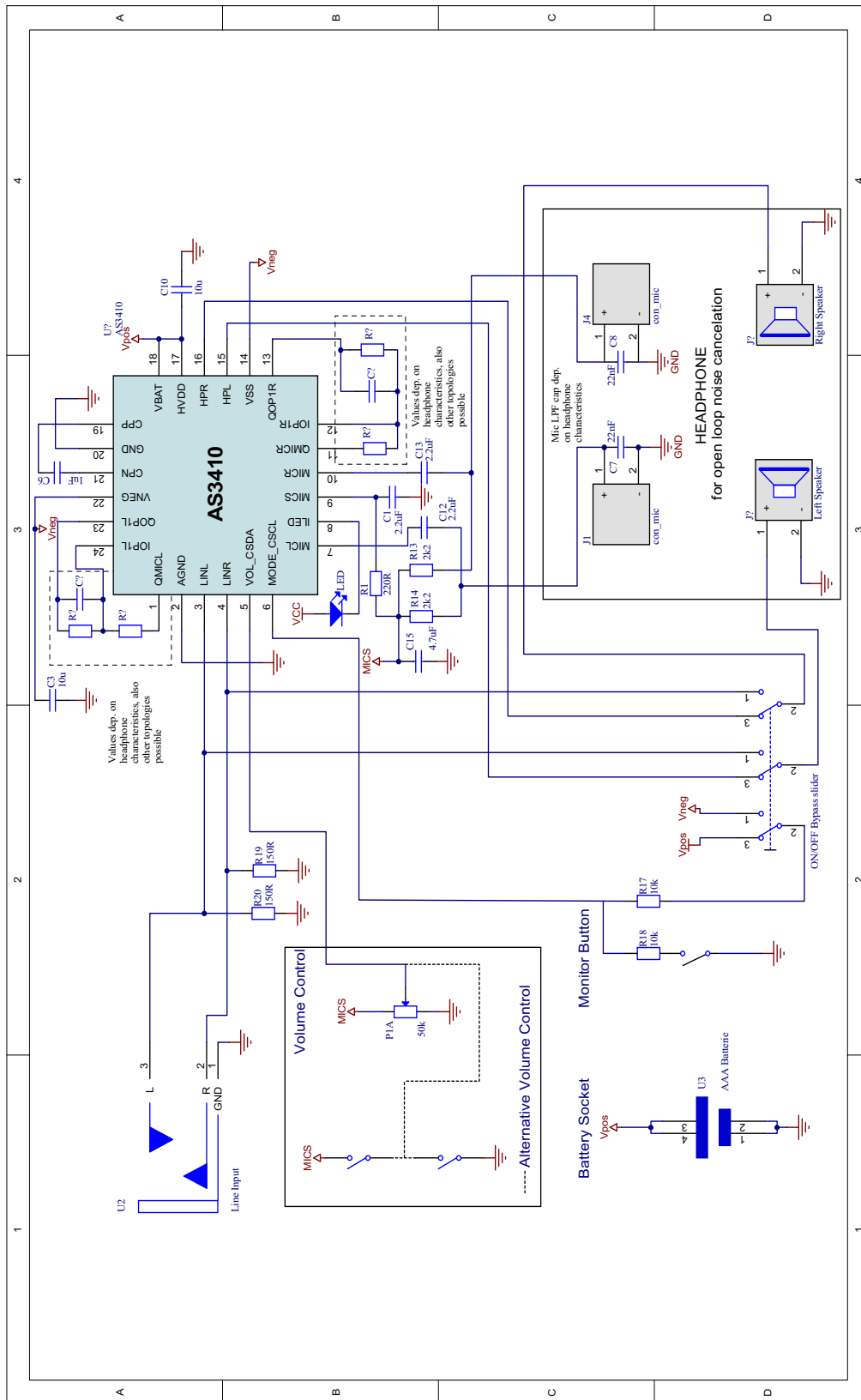

Figure 29. AS3501 Li-Ion battery bridged mode differential feed forward application example

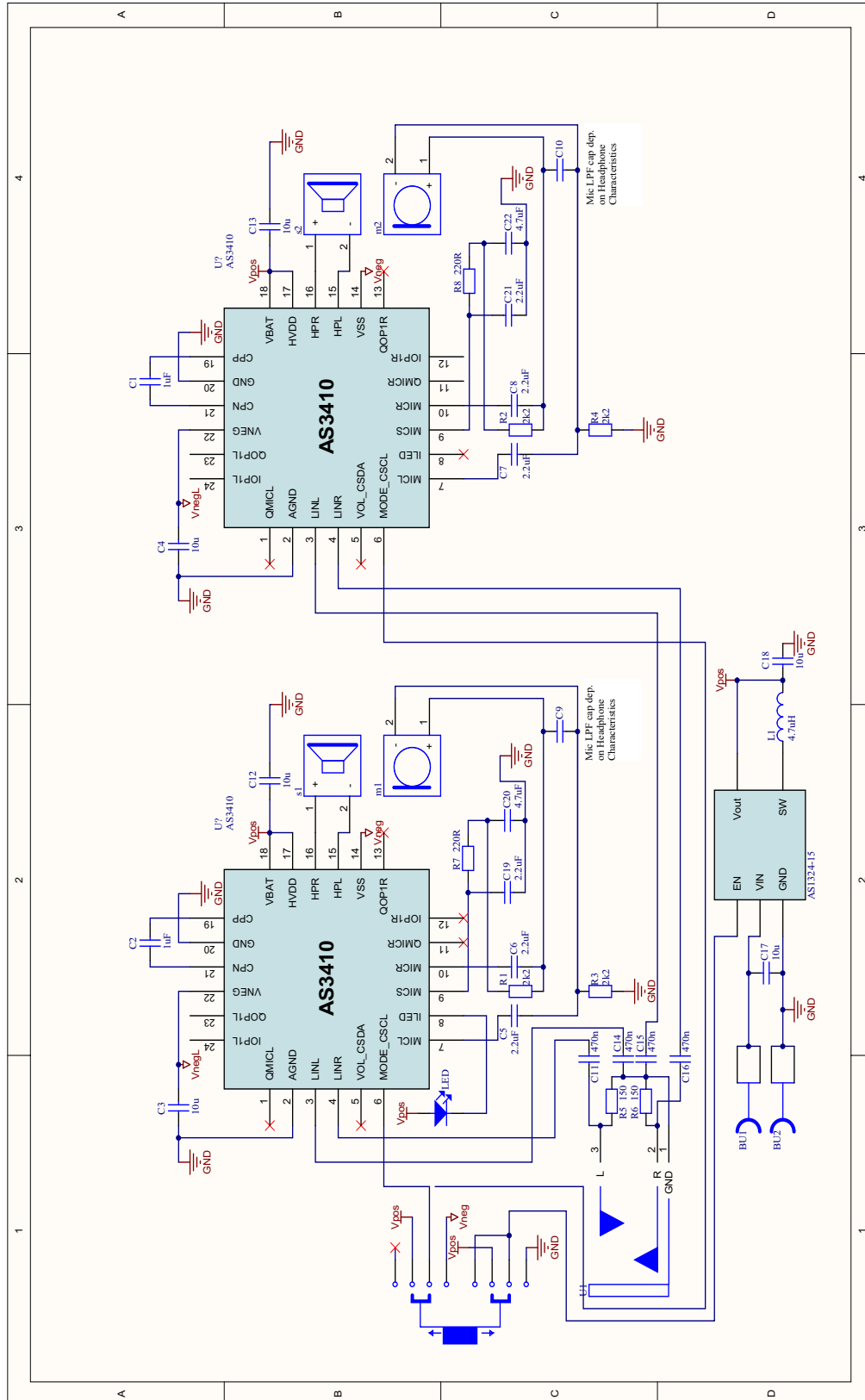
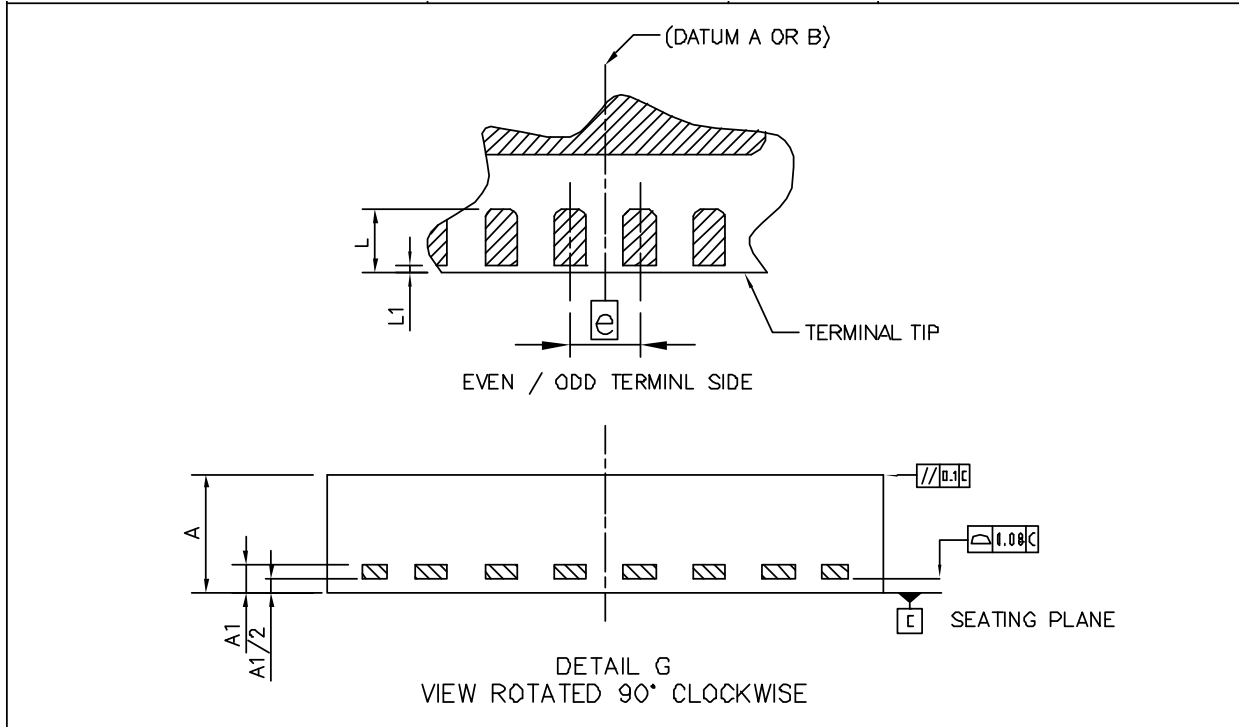

Figure 32. AS3400, AS3410; QFN24 0.5mm pitch details



| DIM | MIN | NOM | MAX | NOTES | | |
|-----|------|----------|------|--|-------------|-------------------------|
| A | 0.75 | 0.85 | 0.95 | 1.0 DIMENSIONING & TOLERANCEING CONFIRM TO ASME Y14.5M-1994. 2.0 ALL DIMENSIONS ARE IN MILLIMETERS. ANGLES ARE IN DEGREES. 3.0 DIMENSION b APPLIES TO METALLIZED TERMINAL AND IS MEASURED BETWEEN 0.25mm AND 0.30mm FROM TERMINAL TIP. DIMENSION L1 REPRESENTS TERMINAL FULL BACK FROM PACKAGE EDGE UP TO 0.1mm IS ACCEPTABLE. 4.0 COPLANARITY APPLIES TO THE EXPOSED HEAT SLUG AS WELL AS THE TERMINAL. 5.0 RADIUS ON TERMINAL IS OPTIONAL. | | |
| A1 | 0.19 | | 0.21 | | | |
| b | 0.18 | 0.23 | 0.28 | | | |
| D | | 4.0 BSC | | | | |
| E | | 4.0 BSC | | | | |
| e | | 0.50 BSC | | | | |
| D1 | 2.10 | 2.20 | 2.30 | | | |
| E1 | 2.10 | 2.20 | 2.30 | | | |
| L | 0.40 | 0.50 | 0.60 | | | |
| L1 | | | 0.10 | | | |
| L2 | 0.30 | 0.40 | 0.50 | | | |
| P | | 45° REF | | | | |
| aaa | | 0.10 | | | | |
| ccc | | 0.10 | | | | |
| | | | | | UNIT | DIMENSION AND TOLERANCE |
| | | | | Millimeter(mm) | ASME Y14.5M | JEDEC MO-220 |

Figure 33. AS3430; QFN32 0.5mm pitch

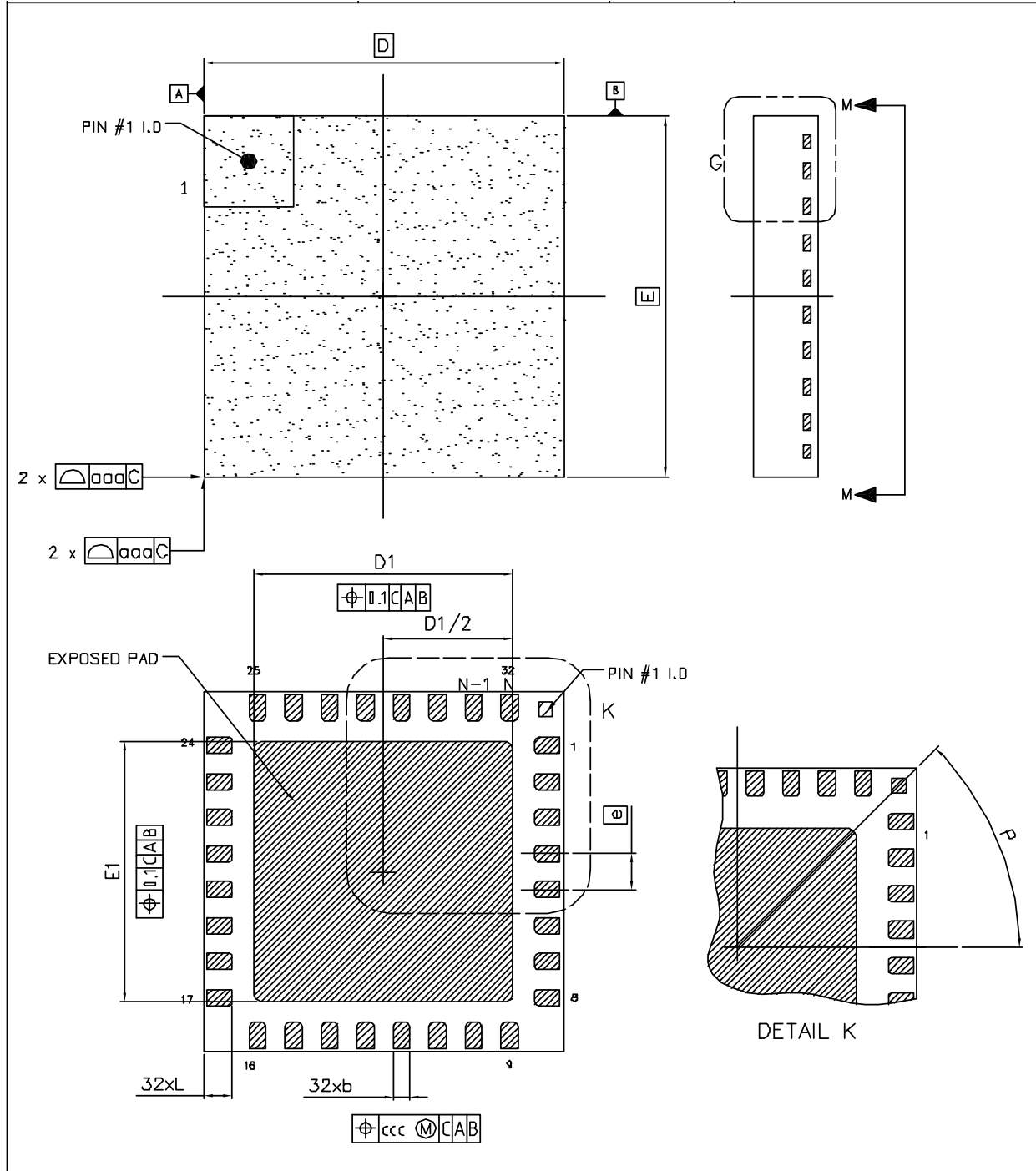
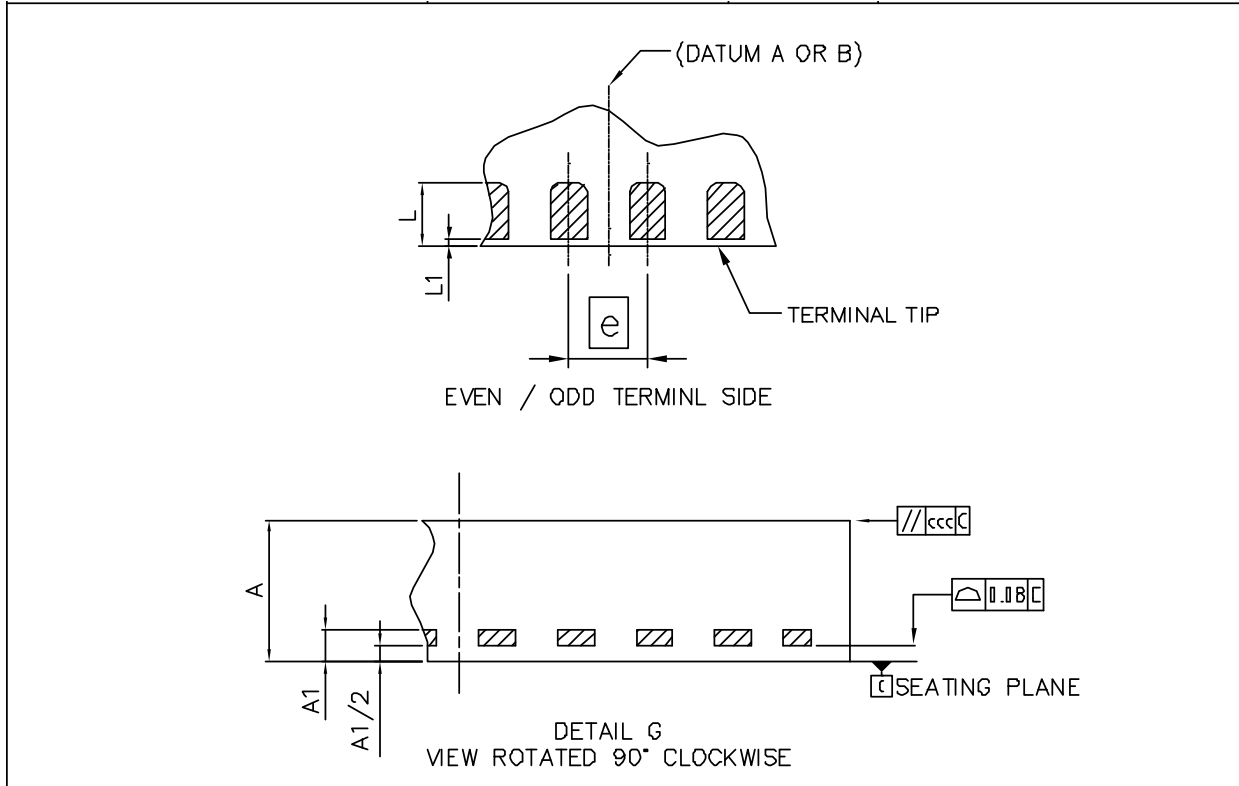

Figure 34. AS3430; QFN32 0.5mm pitch details



| DIM | MIN | NOM | MAX | NOTES |
|-----|------|-----------|------|--|
| A | 0.80 | | 1.00 | 1.0 DIMENSIONING & TOLERANCEING CONFIRM TO ASME Y14.5M-1994. 2.0 ALL DIMENSIONS ARE IN MILLIMETERS. ANGLES ARE IN DEGREES. 3.0 DIMENSION b APPLIES TO METALLIZED TERMINAL AND IS MEASURED BETWEEN 0.25mm AND 0.30mm FROM TERMINAL TIP. DIMENSION L1 REPRESENTS TERMINAL FULL BACK FROM PACKAGE EDGE UP TO 0.1mm IS ACCEPTABLE. 4.0 COPLANARITY APPLIES TO THE EXPOSED HEAT SLUG AS WELL AS THE TERMINAL. 5.0 RADIUS ON TERMINAL IS OPTIONAL. |
| A1 | | 0.203 REF | | |
| b | 0.18 | 0.23 | 0.30 | |
| D | | 5.00 BSC | | |
| E | | 5.00 BSC | | |
| D1 | 3.50 | 3.60 | 3.70 | |
| E1 | 3.50 | 3.60 | 3.70 | |
| e | | 0.50 BSC | | |
| L | 0.30 | 0.40 | 0.50 | |
| L1 | | | 0.10 | |
| P | | 45° BSC | | |
| aaa | | 0.15 | | |
| ccc | | 0.10 | | |
| | | | | UNIT |
| | | | | DIMENSION AND TOLERANCE |
| | | | | REFERENCE DOCUMENT |
| | | | | Millimeter(mm) |
| | | | | ASME Y14.5M |
| | | | | JEDEC MO-220 |

12 Ordering Information

Table 39. Ordering Information

| Model | Description | Delivery Form | Package |
|-------------|---|-------------------------|--|
| AS3400-EQFP | Low Power Ambient Noise-Cancelling Speaker Driver | Tape & Reel dry pack | QFN 24 [4.0x4.0x0.85mm] 0.5mm pitch |
| AS3410-EQFP | Low Power Ambient Noise-Cancelling Speaker Driver | Tape & Reel dry pack | QFN 24 [4.0x4.0x0.85mm] 0.5mm pitch |
| AS3430-EQFP | Low Power Ambient Noise-Cancelling Speaker Driver | Tape & Reel dry pack | QFN 32 [5.0x5.0x0.85mm] 0.5mm pitch |

Copyrights

Copyright © 1997-2010, austriamicrosystems AG, Schloss Premstaetten, 8141 Unterpremstaetten, Austria-Europe. Trademarks Registered ®. All rights reserved. The material herein may not be reproduced, adapted, merged, translated, stored, or used without the prior written consent of the copyright owner.

All products and companies mentioned are trademarks or registered trademarks of their respective companies.

Disclaimer

Devices sold by austriamicrosystems AG are covered by the warranty and patent indemnification provisions appearing in its Term of Sale. austriamicrosystems AG makes no warranty, express, statutory, implied, or by description regarding the information set forth herein or regarding the freedom of the described devices from patent infringement. austriamicrosystems AG reserves the right to change specifications and prices at any time and without notice. Therefore, prior to designing this product into a system, it is necessary to check with austriamicrosystems AG for current information. This product is intended for use in normal commercial applications. Applications requiring extended temperature range, unusual environmental requirements, or high reliability applications, such as military, medical life-support or life-sustaining equipment are specifically not recommended without additional processing by austriamicrosystems AG for each application. For shipments of less than 100 parts the manufacturing flow might show deviations from the standard production flow, such as test flow or test location.

The information furnished here by austriamicrosystems AG is believed to be correct and accurate. However, austriamicrosystems AG shall not be liable to recipient or any third party for any damages, including but not limited to personal injury, property damage, loss of profits, loss of use, interruption of business or indirect, special, incidental or consequential damages, of any kind, in connection with or arising out of the furnishing, performance or use of the technical data herein. No obligation or liability to recipient or any third party shall arise or flow out of austriamicrosystems AG rendering of technical or other services.



Contact Information

Headquarters

austriamicrosystems AG
A-8141 Schloss Premstaetten, Austria

Tel: +43 (0) 3136 500 0
Fax: +43 (0) 3136 525 01

For Sales Offices, Distributors and Representatives, please visit:

<http://www.austriamicrosystems.com/contact>